

AC axial fan - HyBlade

sickle-shaped blades (S series)

with square full nozzle

ZD800-GG07-03 ebmpapst Datasheet

sales@fansco.com

www.fansco.com

Limited partnership · Headquarters Muldingen

Amtsgericht (court of registration) Stuttgart · HRA 590344

General partner Elektrobau Muldingen GmbH · Headquarters Muldingen

Amtsgericht (court of registration) Stuttgart · HRB 590142

Nominal data

Type	WZD800-GG07-03				
Motor	MZD138-HF				
Phase		3~	3~	3~	3~
Nominal voltage	VAC	230	277	400	480
Wiring		Δ	Δ	Y	Y
Frequency	Hz	60	60	60	60
Method of obtaining data		ml	ml	ml	ml
Valid for approval/standard		-	-	-	-
Speed	min ⁻¹	480	510	480	510
Power consumption	W	430	520	430	520
Current draw	A	1.9	2.1	1.1	1.2
Max. back pressure	Pa	44	50	44	50
Min. ambient temperature	°C	-40	-40	-40	-40
Max. ambient temperature	°C	65	65	65	65

ml = Max. load · me = Max. efficiency · fa = Free air · cs = Customer specification · ce = Customer equipment

Subject to change



AC axial fan - HyBlade

sickle-shaped blades (S series)

with square full nozzle

Technical description

Weight	39.7 kg
Fan size	800 mm
Rotor surface	Cast in aluminum
Terminal box material	PP plastic
Blade material	Sheet aluminum insert, sprayed with PP plastic
Fan housing material	Sheet steel, pre-galvanized and coated with black plastic (RAL 9005)
Guard grille material	Steel, coated with black plastic (RAL 9005)
Number of blades	5
Blade pitch	0°
Airflow direction	"V"
Direction of rotation	Clockwise, viewed toward rotor
Degree of protection	IP54
Insulation class	"F"
Moisture (F) / Environmental (H) protection class	F3-1
Max. permitted ambient temp. for motor (transport/storage)	+ 80 °C
Min. permitted ambient temp. for motor (transport/storage)	- 40 °C
Installation position	Any
Condensation drainage holes	On rotor and stator sides
Mode	S1
Motor bearing	Ball bearing
Touch current according to IEC 60990 (measuring circuit Fig. 4, TN system)	<= 3.5 mA
Electrical hookup	Via terminal box
Motor protection	Thermal overload protector (TOP) with basic insulation
With cable	Axial
Protection class	I (with customer connection of protective earth)
Conformity with standards	EN 60034-1 (2010); EN 61800-5-1
Approval	CSA C22.2 No. 100; EAC; UL 1004-1



AC axial fan - HyBlade

sickle-shaped blades (S series)

with square full nozzle

Product drawing

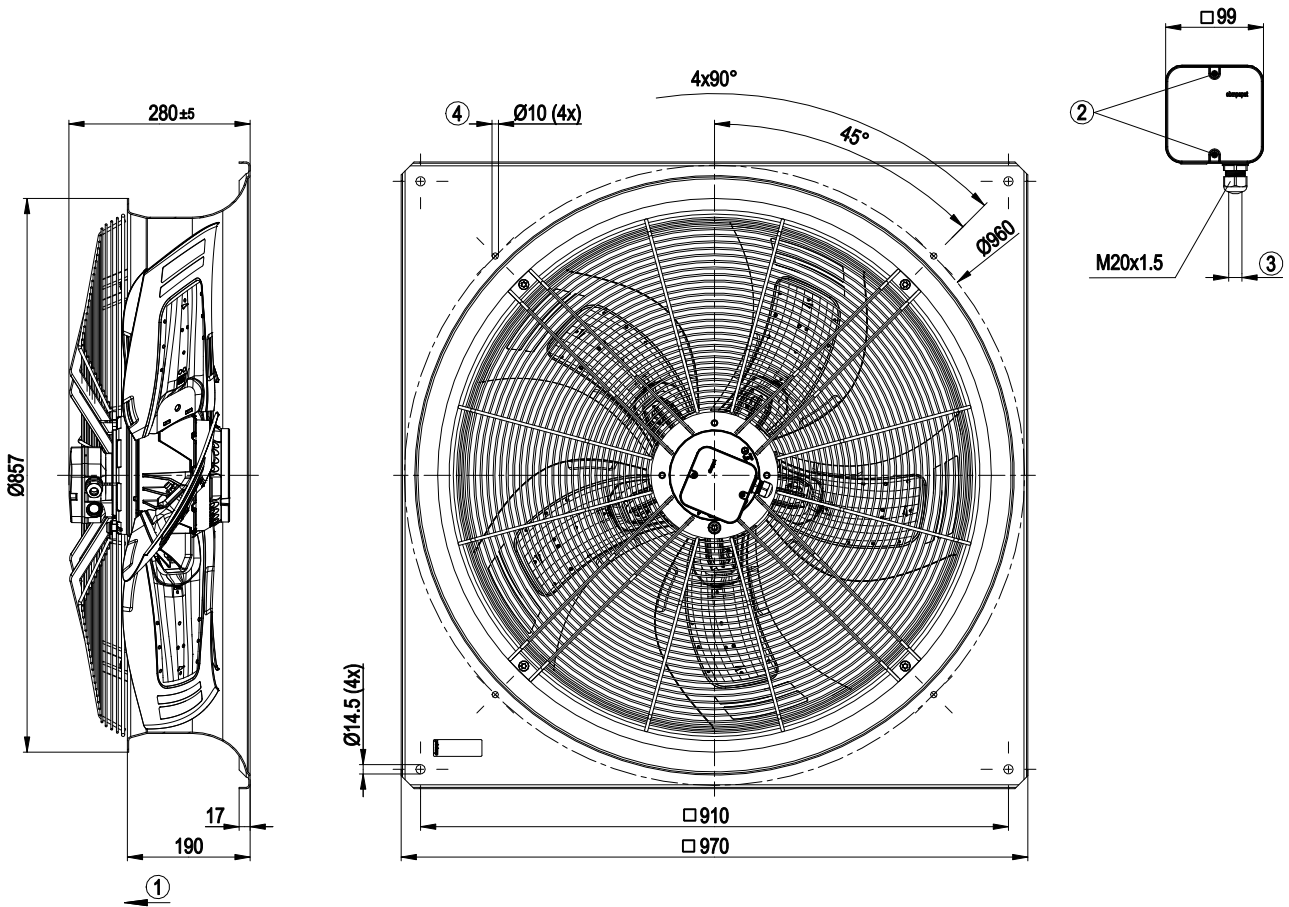

1	Direction of air flow "V"
2	Tightening torque 1.5 ± 0.2 Nm
3	Cable diameter: min. 7 mm, max. 14 mm, tightening torque 2 ± 0.30 Nm
4	Mounting holes for FlowGrid



AC axial fan - HyBlade

sickle-shaped blades (S series)

with square full nozzle

Connection diagram



Δ	Delta connection	Y	Star connection	L1	= U1 = black
L2	= V1 = blue	L3	= W1 = brown	W2	yellow
U2	green	V2	white	TOP	2x gray
PE	green/yellow				



AC axial fan - HyBlade

sickle-shaped blades (S series)

with square full nozzle

Curves: Air performance 60 Hz

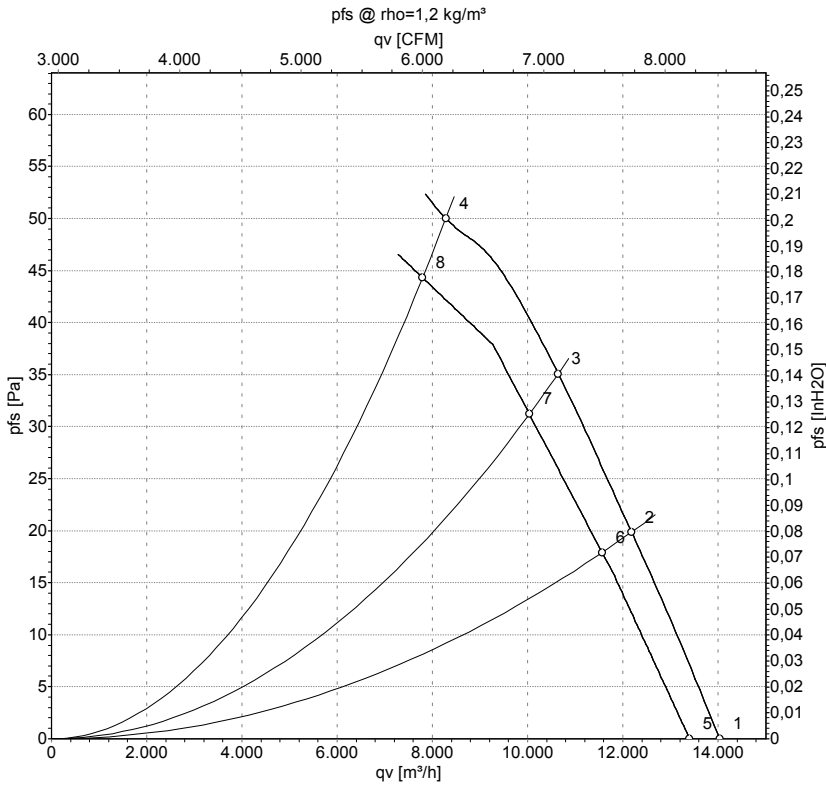

Measurement: LU-115654-1
Measurement: LU-120034-1

Air performance measured according to ISO 5801 installation category A. For detailed information on the measurement setup, contact ebm-papst. Intake sound level: Sound power level according to ISO 13347 / sound pressure level measured at 1 m distance from fan axis. The values given are valid under the specified measuring conditions and may vary due to conditions of installation. For deviations from the standard configuration, the parameters have to be checked on the installed unit.

Measured values

	Wired	U	f	n	P _e	I	LpA _{in}	LwA _{in}	LwA _{out}	qv	p _{fs}
		V	Hz	min ⁻¹	W	A	dB(A)	dB(A)	dB(A)	m ³ /h	Pa
1	Y	480	60	540	412	1.13	53	59	59	14030	0
2	Y	480	60	530	450	1.15	53	59	58	12180	20
3	Y	480	60	525	474	1.17	53	59	58	10640	35
4	Y	480	60	510	520	1.20	54	61	61	8280	50
5	Y	400	60	515	343	0.97	52	58	58	13400	0
6	Y	400	60	505	377	1.00	51	57	57	11560	18
7	Y	400	60	495	395	1.03	51	58	57	10035	31
8	Y	400	60	480	430	1.10	52	60	59	7790	44

Wired = Wiring · U = Power supply · f = Frequency · n = Speed · P_e = Power consumption · I = Current draw · LpA_{in} = Sound pressure level intake side · LwA_{in} = Sound power level intake side
LwA_{out} = Sound power level outlet side · qv = Air flow · p_{fs} = Pressure increase

