

AC axial fan - HyBlade

sickle-shaped blades (S series)

with round full nozzle

W8D990-CE05-85 ebmpapst Datasheet

sales@fansco.com

www.fansco.com

Limited partnership · Headquarters Mulfingen

Amtsgericht (court of registration) Stuttgart · HRA 590344

General partner Elektrobau Mulfingen GmbH · Headquarters Mulfingen

Amtsgericht (court of registration) Stuttgart · HRB 590142

Nominal data

Type	W8D990-CE05-85	
Motor	M8D138-LA	
Phase		3~
Nominal voltage	VAC	415
Wiring		Y
Frequency	Hz	50
Method of obtaining data		fa
Valid for approval/standard		CE
Speed (rpm)	min ⁻¹	680
Power consumption	W	845
Current draw	A	2.3
Max. back pressure	Pa	92
Max. back pressure	in. wg	0.37
Min. ambient temperature	°C	-25
Max. ambient temperature	°C	70
Starting current	A	6.5

ml = Max. load · me = Max. efficiency · fa = Free air · cs = Customer specification · ce = Customer equipment
Subject to change

Data according to Commission Regulation (EU) 327/2011

		Actual	Req. 2015		
01 Overall efficiency η_{es}	%	34	34	09 Power consumption P_e	kW 1.11
02 Measurement category		A		09 Air flow q_v	m ³ /h 15765
03 Efficiency category		Static		09 Pressure increase p_{fs}	Pa 85
04 Efficiency grade N		40	40	10 Speed (rpm) n	min ⁻¹ 645
05 Variable speed drive		No		11 Specific ratio*	1.00

Data obtained at optimum efficiency level.

The ErP data is determined using a motor-impeller combination in a standardized measurement setup.

* Specific ratio = $1 + p_{fs} / 100\,000\text{ Pa}$

LU-189058



AC axial fan - HyBlade

sickle-shaped blades (S series)

with round full nozzle

Technical description

Weight	53.1 kg
Size	990 mm
Motor size	138
Rotor surface	Painted black
Terminal box material	Die-cast aluminum, painted black
Blade material	Sheet aluminum insert (painted black), sprayed with PP plastic
Fan housing material	Sheet steel, galvanized and coated with white aluminum plastic (RAL 9006)
Guard grille material	Steel, coated with white-aluminum plastic (RAL 9006)
Number of blades	5
Blade pitch	-5°
Airflow direction	A
Direction of rotation	Counterclockwise, viewed toward rotor
Degree of protection	IP55
Insulation class	"F"
Moisture (F) / Environmental (H) protection class	H2+T
Ambient temperature note	Occasional start-up at temperatures between -40°C and -25°C is permitted. For continuous operation at ambient temperatures below -25°C (such as refrigeration applications), use must be made of a fan design with special low-temperature bearings.
Max. permitted ambient temp. for motor (transport/storage)	+80 °C
Min. permitted ambient temp. for motor (transport/storage)	-40 °C
Installation position	Shaft horizontal or rotor on top; rotor on bottom on request
Condensation drainage holes	On stator side
Mode	S1
Motor bearing	Ball bearing
Touch current according to IEC 60990 (measuring circuit Fig. 4, TN system)	≤ 3.5 mA
Electrical hookup	Terminal box
Motor protection	Thermal overload protector (TOP) with basic insulation
With cable	Axial
Protection class	I (with customer connection of protective earth)
Conformity with standards	EN 60034-1 (2010); CE
Approval	CSA C22.2 No. 100; UL 1004-1; EAC



AC axial fan - HyBlade

sickle-shaped blades (S series)

with round full nozzle

Product drawing

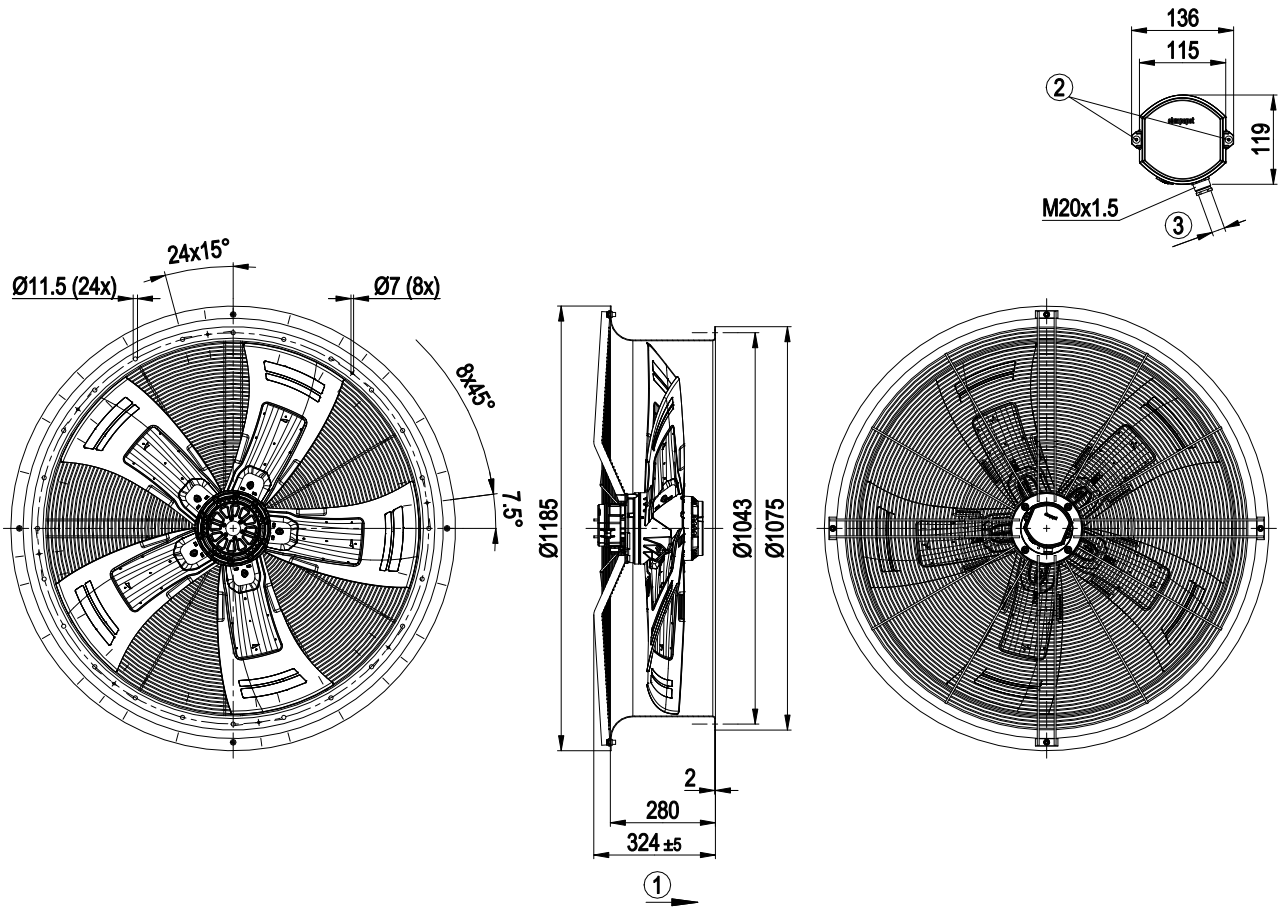

1	Direction of air flow "A"
2	Tightening torque 2.5 ± 0.4 Nm
3	Cable diameter min. 10 mm, max. 12 mm, tightening torque 4±0.6 Nm



AC axial fan - HyBlade

sickle-shaped blades (S series)

with round full nozzle

Connection diagram

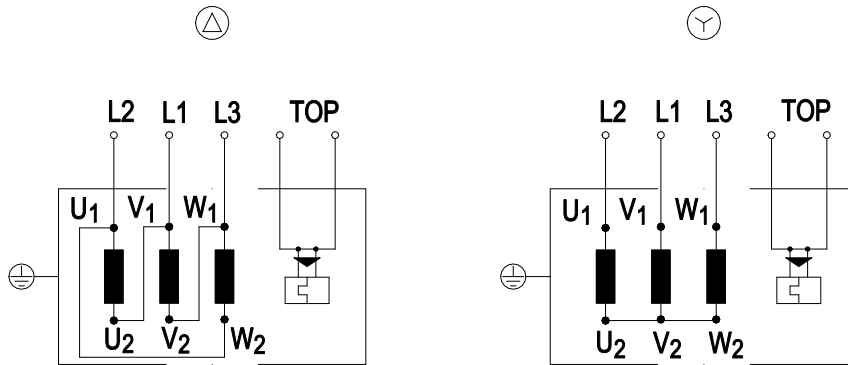

Change of rotation direction by reversing two phases

Δ	Delta connection	Y	Star connection	L2	= U1 = black
L1	= V1 = blue	L3	= W1 = brown	W2	yellow
U2	green	V2	white	TOP	2x gray
PE	green/yellow				



AC axial fan - HyBlade

sickle-shaped blades (S series)

with round full nozzle

Curves: Air performance 50 Hz

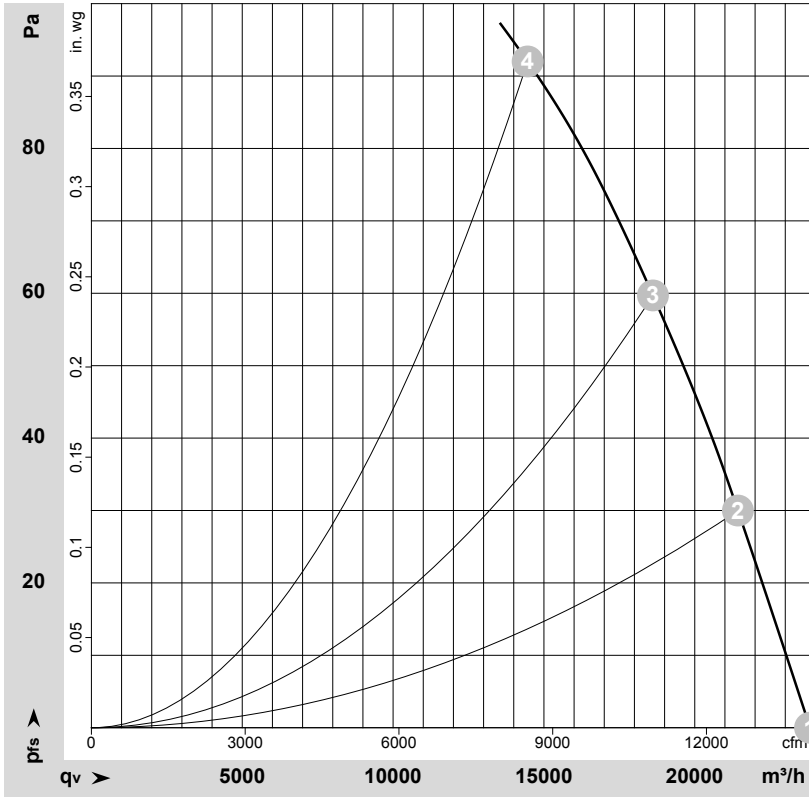

$\rho = 1.15 \text{ kg/m}^3 \pm 2 \%$

Measurement: LU-189058-1

Air performance measured according to ISO 5801 installation category A. For detailed information on the measurement setup, contact ebmpapst. Intake sound level: Sound power level according to ISO 13347 / sound pressure level measured at 1 m distance from fan axis. The values given are valid under the specified measuring conditions and may vary due to conditions of installation. For deviations from the standard configuration, the parameters have to be checked on the installed unit.

Measured values

	Wired	U	f	n	P _e	I	LpA _{in}	LwA _{in}	LwA _{out}	q _v	p _{fs}	q _v	p _{fs}
		V	Hz	min ⁻¹	W	A	dB(A)	dB(A)	dB(A)	m ³ /h	Pa	cfm	in. wg
1	Y	415	50	680	845	2.30	69	76	76	23820	0	14020	0.00
2	Y	415	50	665	958	2.41	69	75	75	21430	30	12615	0.12
3	Y	415	50	655	1049	2.51	69	75	75	18615	60	10955	0.24
4	Y	415	50	645	1132	2.61	74	80	80	14460	92	8510	0.37

Wired = Wiring · U = Voltage · f = Frequency · n = Speed (rpm) · P_e = Power consumption · I = Current draw · LpA_{in} = Sound pressure level intake side · LwA_{in} = Sound power level intake side
 LwA_{out} = Sound power level outlet side · q_v = Air flow · p_{fs} = Pressure increase

