

AC axial fan - HyBlade

sickle-shaped blades (S series)

with square full nozzle

W8D910-GD03-12 ebmpapst Datasheet

sales@fansco.com

www.fansco.com

Limited partnership · Headquarters Mulfingen

Amtsgericht (court of registration) Stuttgart · HRA 590344

General partner Elektrobau Mulfingen GmbH · Headquarters Mulfingen

Amtsgericht (court of registration) Stuttgart · HRB 590142

Nominal data

Type	W8D910-GD03-12		
Motor	M8D138-LA		
Phase		3~	3~
Nominal voltage	VAC	400	400
Wiring		Δ	Y
Frequency	Hz	50	50
Method of obtaining data		ml	ml
Valid for approval/standard		-	-
Speed	min ⁻¹	650	475
Power consumption	W	1150	640
Current draw	A	2.78	1.36
Max. back pressure	Pa	90	47
Min. ambient temperature	°C	-40	-40
Max. ambient temperature	°C	65	65
Starting current	A	6.2	2.1

ml = Max. load · me = Max. efficiency · fa = Free air · cs = Customer specification · ce = Customer equipment
Subject to change



AC axial fan - HyBlade

sickle-shaped blades (S series)

with square full nozzle

Technical description

Weight	49.8 kg
Fan size	910 mm
Rotor surface	Cast in aluminum
Terminal box material	PP plastic
Fan housing material	Sheet steel, pre-galvanized and coated with pebble-gray plastic (RAL 7032)
Guard grille material	Steel, coated with black plastic (RAL 9005)
Number of blades	5
Blade pitch	0°
Airflow direction	"V"
Direction of rotation	Clockwise, viewed toward rotor
Degree of protection	IP54
Insulation class	"F"
Moisture (F) / Environmental (H) protection class	F3-1
Max. permitted ambient temp. for motor (transport/storage)	+ 80 °C
Min. permitted ambient temp. for motor (transport/storage)	- 40 °C
Installation position	Any
Condensation drainage holes	On rotor and stator sides
Mode	S1
Motor bearing	Ball bearing
Touch current according to IEC 60990 (measuring circuit Fig. 4, TN system)	<= 3.5 mA
Electrical hookup	Via terminal box
Motor protection	Thermal overload protector (TOP) with basic insulation
Protection class	I (with customer connection of protective earth)
Conformity with standards	EN 60034-1 (2010); EN 61800-5-1
Approval	EAC; VDE



AC axial fan - HyBlade

sickle-shaped blades (S series)

with square full nozzle

Product drawing

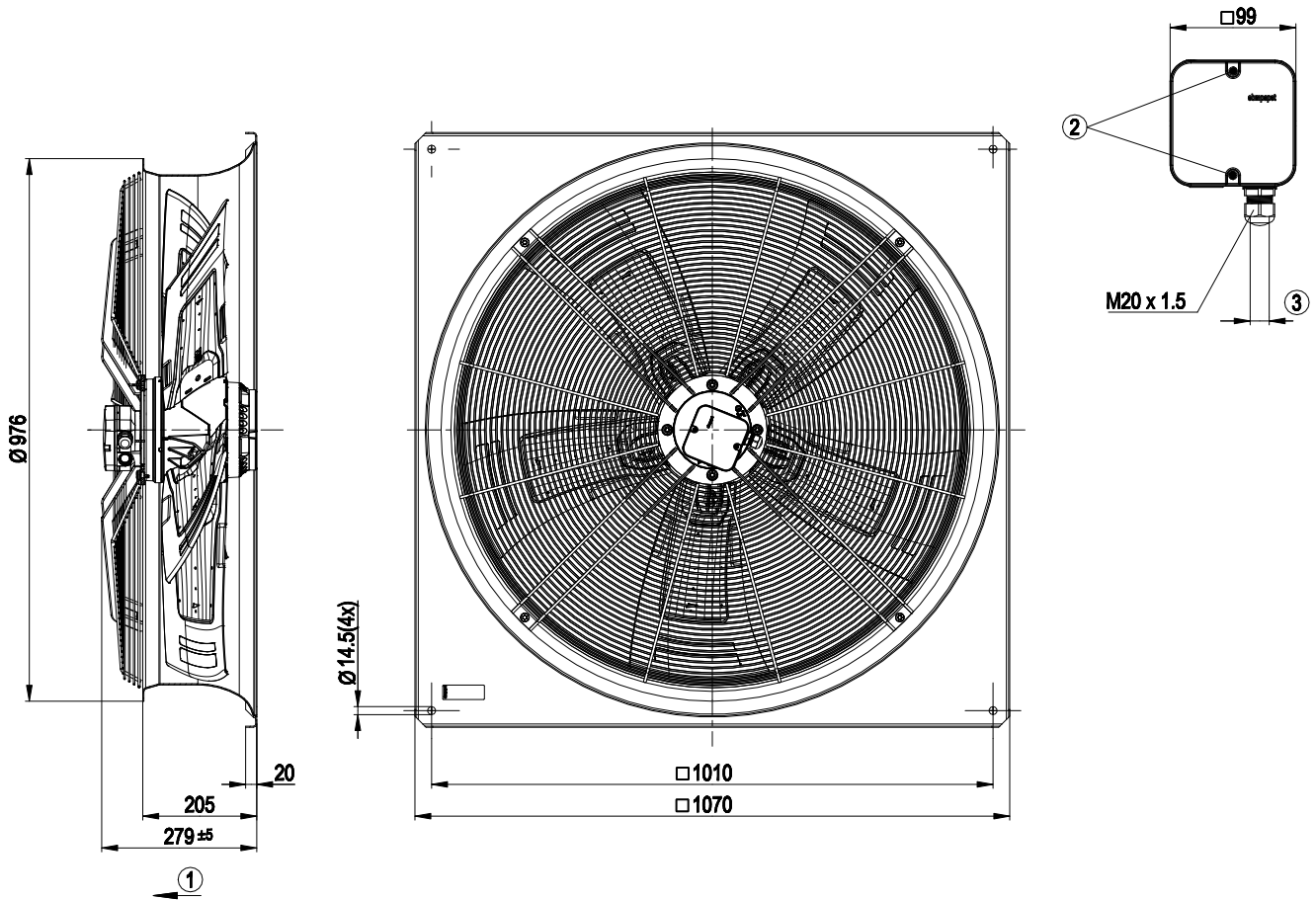

1	Direction of air flow "V"
2	Tightening torque 1.5 ± 0.2 Nm
3	Cable diameter: min. 7 mm, max. 14 mm; tightening torque 2 ± 0.3 Nm



AC axial fan - HyBlade

sickle-shaped blades (S series)

with square full nozzle

Connection diagram



Δ	Delta connection	Y	Star connection	L1	= U1 = black
L2	= V1 = blue	L3	= W1 = brown	W2	yellow
U2	green	V2	white	TOP	2x gray
PE	green/yellow				



Curves: Air performance 50 Hz

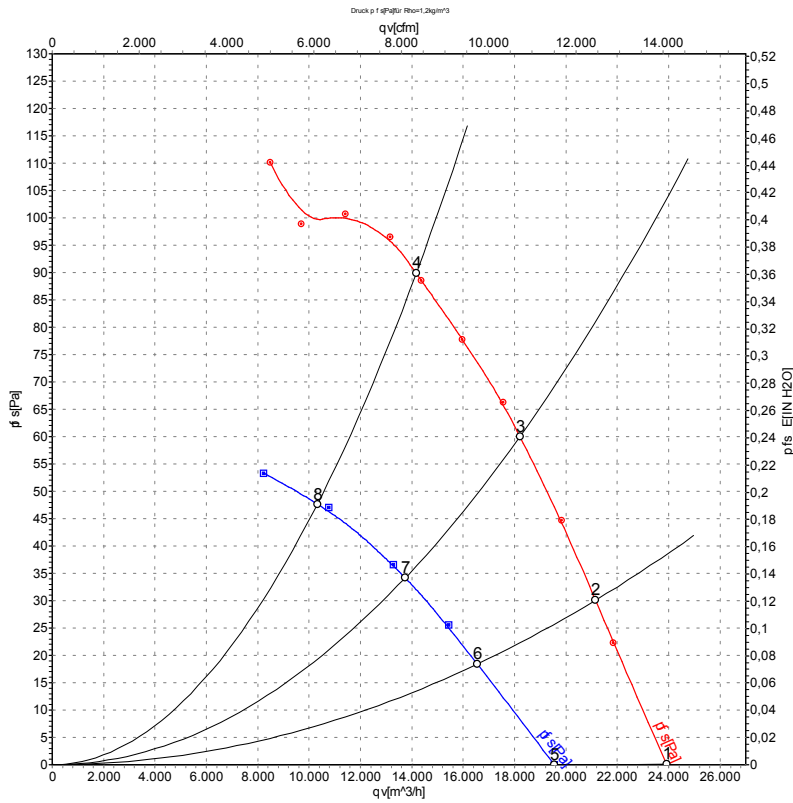

Measurement: LU-117443-1
Measurement: LU-117777-1

Air performance measured according to ISO 5801 installation category A. For detailed information on the measurement setup, contact ebm-papst. Intake sound level: Sound power level according to ISO 13347 / sound pressure level measured at 1 m distance from fan axis. The values given are valid under the specified measuring conditions and may vary due to conditions of installation. For deviations from the standard configuration, the parameters have to be checked on the installed unit.

Measured values

	Wired	U	f	n	P _e	I	LpA _{in}	LwA _{in}	LwA _{out}	qv	p _{fs}
		V	Hz	min ⁻¹	W	A	dB(A)	dB(A)	dB(A)	m ³ /h	Pa
1	Δ	400	50	690	840	2.46	62	70	70	23920	0
2	Δ	400	50	675	950	2.57	61	68	67	21150	30
3	Δ	400	50	665	1046	2.67	60	67	66	18210	60
4	Δ	400	50	650	1150	2.78	63	70	69	14170	90
5	Y	400	50	565	555	1.18	57	64	64	19550	0
6	Y	400	50	530	590	1.24	55	61	61	16550	19
7	Y	400	50	500	620	1.31	53	59	59	13740	34
8	Y	400	50	475	640	1.36	56	63	62	10320	47

Wired = Wiring · U = Power supply · f = Frequency · n = Speed · P_e = Power consumption · I = Current draw · LpA_{in} = Sound pressure level intake side · LwA_{in} = Sound power level intake side
LwA_{out} = Sound power level outlet side · qv = Air flow · p_{fs} = Pressure increase



AC axial fan - HyBlade

sickle-shaped blades (S series)

with square full nozzle

Curves: Air performance 60 Hz

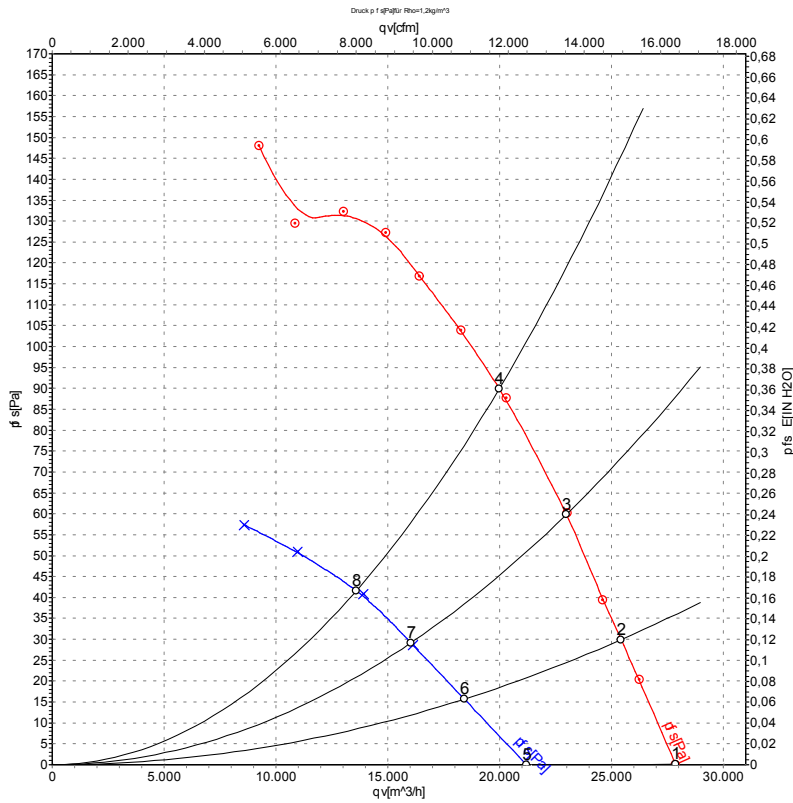

Measurement: LU-117444-1
Measurement: LU-127566-1

Air performance measured according to ISO 5801 installation category A. For detailed information on the measurement setup, contact ebm-papst. Intake sound level: Sound power level according to ISO 13347 / sound pressure level measured at 1 m distance from fan axis. The values given are valid under the specified measuring conditions and may vary due to conditions of installation. For deviations from the standard configuration, the parameters have to be checked on the installed unit.

Measured values

	Wired	U	f	n	P_e	I	$L_{pA_{in}}$	$L_{wA_{in}}$	$L_{wA_{out}}$	q_v	p_{fs}
		V	Hz	min ⁻¹	W	A	dB(A)	dB(A)	dB(A)	m³/h	Pa
1	Δ	480	60	805	1329	2.76	66	74	74	27870	0
2	Δ	480	60	795	1468	2.95	64	72	72	25430	30
3	Δ	480	60	780	1584	3.07	63	71	71	22980	60
4	Δ	480	60	760	1720	3.25	64	71	71	19980	90
5	Y	480	60	605	795	1.43	59	66	66	21200	0
6	Y	480	60	570	820	1.48	56	64	63	18420	16
7	Y	480	60	540	841	1.52	55	62	61	16030	29
8	Y	480	60	520	860	1.62	54	61	60	13590	42

Wired = Wiring · U = Power supply · f = Frequency · n = Speed · P_e = Power consumption · I = Current draw · $L_{pA_{in}}$ = Sound pressure level intake side · $L_{wA_{in}}$ = Sound power level intake side
 $L_{wA_{out}}$ = Sound power level outlet side · q_v = Air flow · p_{fs} = Pressure increase

