

# AC axial fan - HyBlade

sickle-shaped blades (S series)  
with square full nozzle with AxiTop diffuser

W8D800-HD01-01 ebmpapst Datasheet  
sales@fansco.com  
www.fansco.com

Limited partnership · Headquarters Mulfingen  
Amtsgericht (court of registration) Stuttgart · HRA 590344  
General partner Elektrobau Mulfingen GmbH · Headquarters Mulfingen  
Amtsgericht (court of registration) Stuttgart · HRB 590142

## Nominal data

Type	W8D800-HD01-01		
Motor	M8D138-LA		
Phase		3~	3~
Nominal voltage	VAC	400	400
Wiring		$\Delta$	Y
Frequency	Hz	50	50
Method of obtaining data		ml	ml
Valid for approval/standard		CE	CE
Speed (rpm)	min <sup>-1</sup>	670	510
Power consumption	W	880	550
Current draw	A	2.25	1.15
Max. back pressure	Pa	90	54
Max. back pressure	inH <sub>2</sub> O	0.36	0.22
Min. ambient temperature	°C	-25	-25
Max. ambient temperature	°C	70	70
Starting current	A	6	2

ml = Max. load · me = Max. efficiency · fa = Free air · cs = Customer specification · ce = Customer equipment  
Subject to change

## Data according to Commission Regulation (EU) 327/2011

		Actual	Req. 2015			
01 Overall efficiency $\eta_{es}$	%	33.5	33.2	09 Power consumption $P_e$	kW	0.83
02 Measurement category		A		09 Air flow $q_v$	m <sup>3</sup> /h	13435
03 Efficiency category		Static		09 Pressure increase $p_{fs}$	Pa	75
04 Efficiency grade N		40.3	40	10 Speed (rpm) n	min <sup>-1</sup>	680
05 Variable speed drive		No		11 Specific ratio*		1.00

Data obtained at optimum efficiency level.  
The ErP data is determined using a motor-impeller combination in a standardized measurement setup.

\* Specific ratio =  $1 + p_{fs} / 100\,000\text{ Pa}$

LU-158273



# AC axial fan - HyBlade

sickle-shaped blades (S series)  
with square full nozzle with AxiTop diffuser

## Technical description

Weight	52 kg
Fan size	800 mm
Rotor surface	Cast in aluminum
Terminal box material	PC plastic
Blade material	Sheet aluminum insert, sprayed with PP plastic
Support ring material	Steel, coated with black plastic (RAL 9005)
Fan housing material	Sheet steel, pre-galvanized and coated with black plastic (RAL 9005)
Guard grille material	Steel, coated with black plastic (RAL 9005)
Outer diffuser material	PP plastic
Internal diffuser material including cover	PP plastic
Number of blades	5
Blade pitch	0°
Airflow direction	"V"
Direction of rotation	Clockwise, viewed toward rotor
Degree of protection	IP54
Insulation class	"F"
Moisture (F) / Environmental (H) protection class	F3-1
Ambient temperature note	Occasional start-up between -40°C and -25°C is permissible. For continuous operation at temperatures below -25°C (e.g. refrigeration applications) we recommend our fan design with special low-temperature bearings.
Max. permitted ambient temp. for motor (transport/storage)	+80 °C
Min. permitted ambient temp. for motor (transport/storage)	-40 °C
Installation position	Shaft horizontal or rotor on bottom; rotor on top on request
Condensation drainage holes	On rotor and stator sides
Mode	S1
Motor bearing	Ball bearing
Touch current according to IEC 60990 (measuring circuit Fig. 4, TN system)	<= 3.5 mA
Electrical hookup	Via terminal box
Motor protection	Thermal overload protector (TOP) with basic insulation
With cable	Lateral
Protection class	I (with customer connection of protective earth)
Conformity with standards	EN 60034-1 (2010); EN 61800-5-1; CE
Approval	VDE; EAC



# AC axial fan - HyBlade

sickle-shaped blades (S series)  
with square full nozzle with AxiTop diffuser

## Product drawing

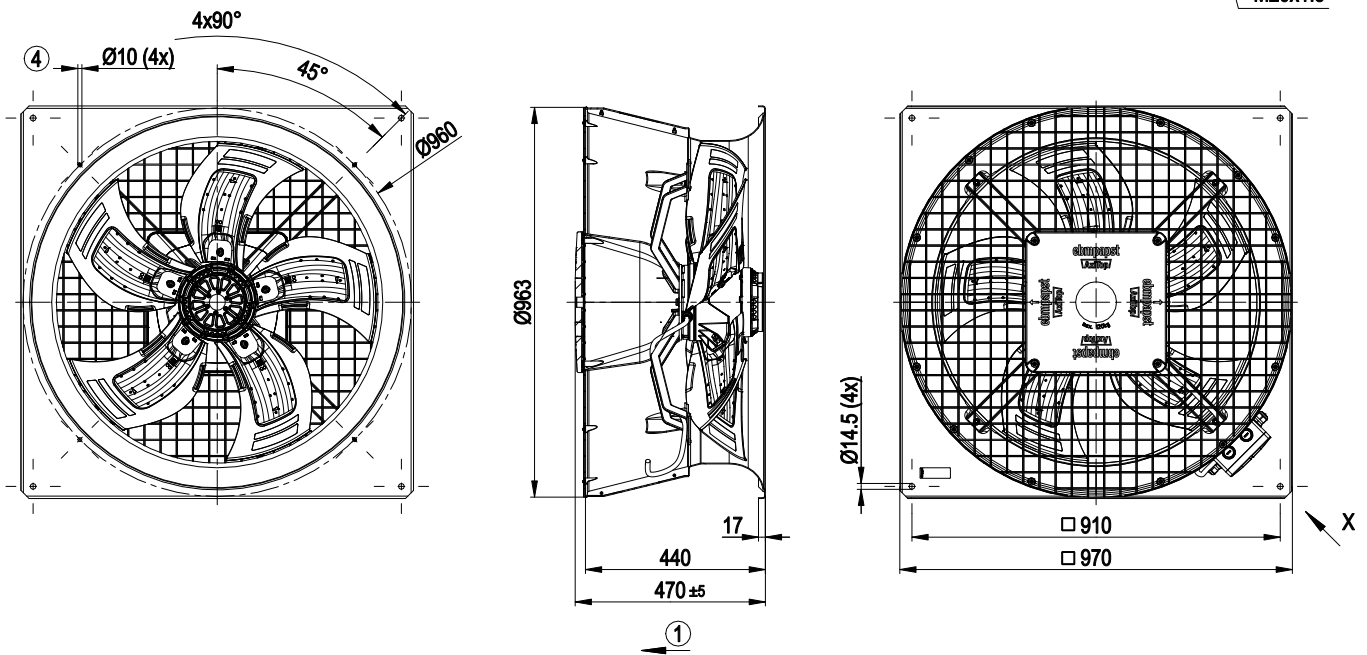
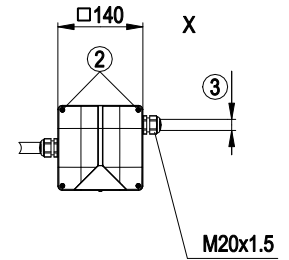

1	Direction of air flow "V"
2	Tightening torque $1.7 \pm 0.2$ Nm
3	Cable diameter: min. 6 mm, max. 12 mm; tightening torque $4 \pm 0.6$ Nm
4	Mounting holes for FlowGrid



# AC axial fan - HyBlade

sickle-shaped blades (S series)  
with square full nozzle with AxiTop diffuser

## Connection diagram

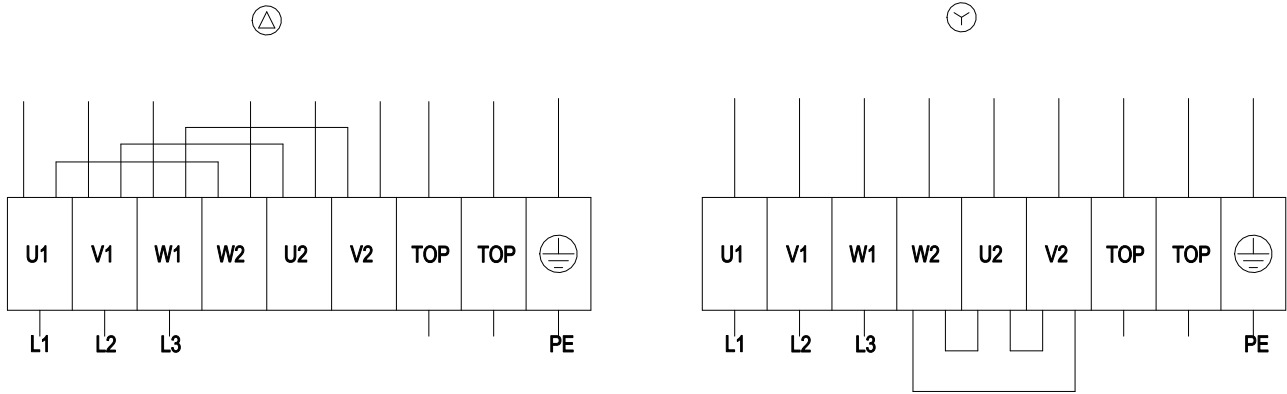

Δ	Delta connection	Y	Star connection	L1	= U1 = black
L2	= V1 = blue	L3	= W1 = brown	W2	yellow
U2	green	V2	white	TOP	2x gray
PE	green/yellow				



# AC axial fan - HyBlade

sickle-shaped blades (S series)  
with square full nozzle with AxiTop diffuser

## Curves: Air performance 50 Hz

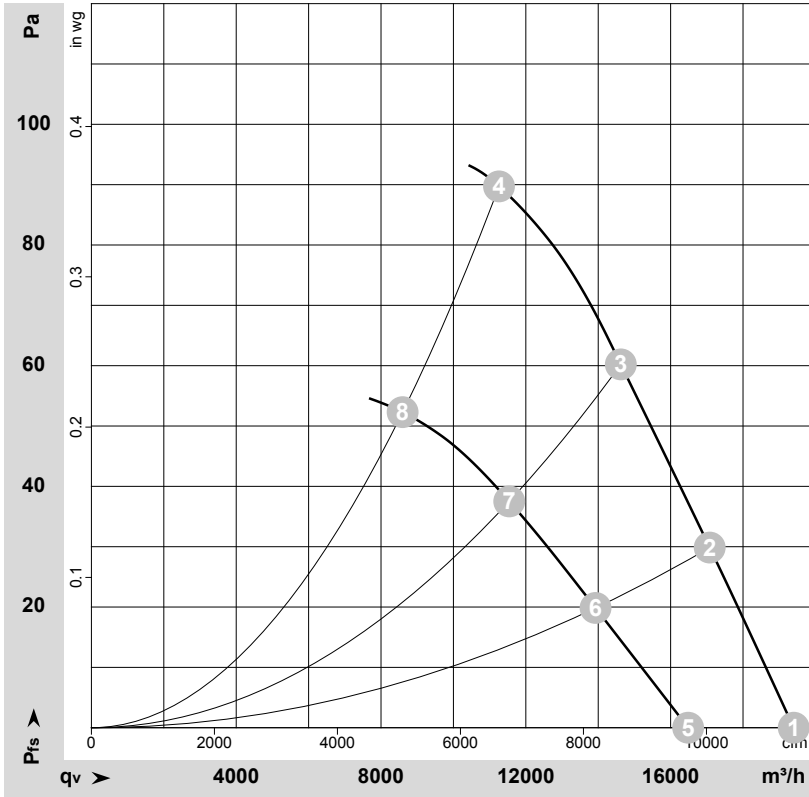

$\rho = 1.15 \text{ kg/m}^3 \pm 2 \%$

Measurement: LU-158273-1  
Measurement: LU-158270-1

Air performance measured according to ISO 5801 installation category A. For detailed information on the measurement setup, contact ebm-papst. Intake sound level: Sound power level according to ISO 13347 / sound pressure level measured at 1 m distance from fan axis. The values given are valid under the specified measuring conditions and may vary due to conditions of installation. For deviations from the standard configuration, the parameters have to be checked on the installed unit.

## Measured values

	Wired	U	f	n	P <sub>e</sub>	I	LpA <sub>in</sub>	LwA <sub>in</sub>	LwA <sub>out</sub>	q <sub>v</sub>	p <sub>fs</sub>	q <sub>v</sub>	p <sub>fs</sub>
		V	Hz	min <sup>-1</sup>	W	A	dB(A)	dB(A)	dB(A)	m <sup>3</sup> /h	Pa	cfm	inH <sub>2</sub> O
1	Δ	400	50	700	635	2.01	61	67	68	19400	0	11420	0.00
2	Δ	400	50	690	722	2.09	58	65	65	17080	30	10055	0.12
3	Δ	400	50	680	801	2.18	59	66	66	14625	60	8605	0.24
4	Δ	400	50	670	880	2.25	61	68	68	11260	90	6625	0.36
5	Y	400	50	595	443	0.95	57	64	64	16485	0	9700	0.00
6	Y	400	50	565	490	1.04	54	61	61	13925	20	8195	0.08
7	Y	400	50	540	521	1.10	54	60	60	11540	38	6795	0.15
8	Y	400	50	510	550	1.15	54	62	61	8595	52	5060	0.21

Wired = Wiring · U = Power supply · f = Frequency · n = Speed (rpm) · P<sub>e</sub> = Power consumption · I = Current draw · LpA<sub>in</sub> = Sound pressure level intake side · LwA<sub>in</sub> = Sound power level intake side  
LwA<sub>out</sub> = Sound power level outlet side · q<sub>v</sub> = Air flow · p<sub>fs</sub> = Pressure increase

