

# AC axial fan - HyBlade

sickle-shaped blades (S series)

with square full nozzle

W8D500-GJ03-01 ebmpapst Datasheet

sales@fansco.com

www.fansco.com

Limited partnership · Headquarters Mulfingen

Amtsgericht (court of registration) Stuttgart · HRA 590344

General partner Elektrobau Mulfingen GmbH · Headquarters Mulfingen

Amtsgericht (court of registration) Stuttgart · HRB 590142

## Nominal data

Type	W8D500-GJ03-01				
Motor	M8D110-EF				
Phase		3~	3~	3~	3~
Nominal voltage	VAC	400	400	480	480
Wiring		Δ	Y	Δ	Y
Frequency	Hz	50	50	60	60
Method of obtaining data		ml	ml	ml	ml
Valid for approval/standard		-	-	-	-
Speed (rpm)	min <sup>-1</sup>	680	560	810	630
Power consumption	W	150	90	210	140
Current draw	A	0.4	0.18	0.41	0.22
Max. back pressure	Pa	40	28	55	
Max. back pressure	inH <sub>2</sub> O	0.16	0.11	0.22	
Min. ambient temperature	°C	-40	-40	-40	-40
Max. ambient temperature	°C	65	65	65	65
Starting current	A	0.87		0.95	

ml = Max. load · me = Max. efficiency · fa = Free air · cs = Customer specification · ce = Customer equipment  
Subject to change



# AC axial fan - HyBlade

sickle-shaped blades (S series)

with square full nozzle

## Technical description

Weight	14.3 kg
Fan size	500 mm
Rotor surface	Painted black
Terminal box material	PP plastic
Blade material	Press-fitted sheet steel blank, sprayed with PP plastic
Fan housing material	Sheet steel, pre-galvanized and coated with black plastic (RAL 9005)
Guard grille material	Steel, coated with black plastic (RAL 9005)
Number of blades	5
Airflow direction	"V"
Direction of rotation	Counterclockwise, viewed toward rotor
Degree of protection	IP54
Insulation class	"F"
Moisture (F) / Environmental (H) protection class	F4-1
Max. permitted ambient temp. for motor (transport/storage)	+ 80 °C
Min. permitted ambient temp. for motor (transport/storage)	- 40 °C
Installation position	Shaft horizontal or rotor on bottom; rotor on top on request
Condensation drainage holes	On rotor side
Mode	S1
Motor bearing	Ball bearing
Touch current according to IEC 60990 (measuring circuit Fig. 4, TN system)	<= 3.5 mA
Electrical hookup	Via terminal box
Motor protection	Thermal overload protector (TOP) with basic insulation
With cable	Axial
Protection class	I (with customer connection of protective earth)
Conformity with standards	EN 61800-5-1
Approval	VDE; EAC



# AC axial fan - HyBlade

sickle-shaped blades (S series)

with square full nozzle

## Product drawing

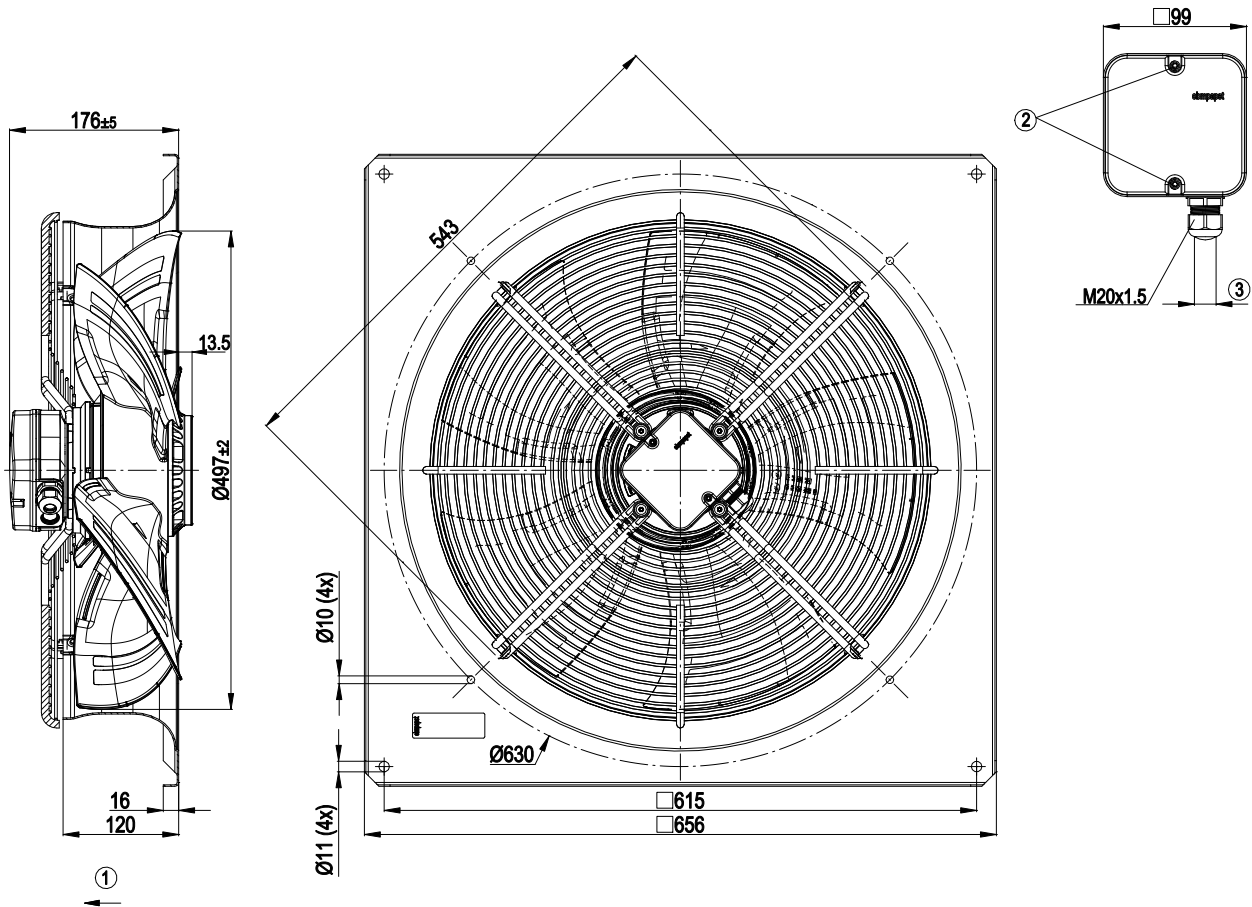

1	Direction of air flow "V"
2	Tightening torque 1.5 ± 0.2 Nm
3	Cable diameter: min. 6 mm, max. 12 mm, tightening torque 2±0.3 Nm



# AC axial fan - HyBlade

sickle-shaped blades (S series)

with square full nozzle

## Connection diagram

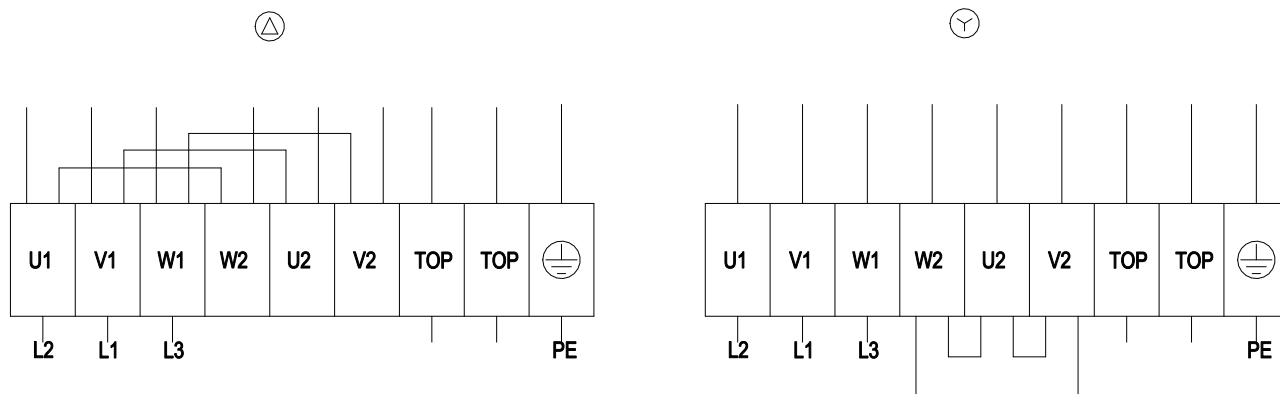

Δ	Delta connection	Y	Star connection	L1	= V1 = blue
L2	= U1 = black	L3	= W1 = brown	W2	yellow
U2	green	V2	white	TOP	2x gray
PE	green/yellow				



## Curves: Air performance 50 Hz

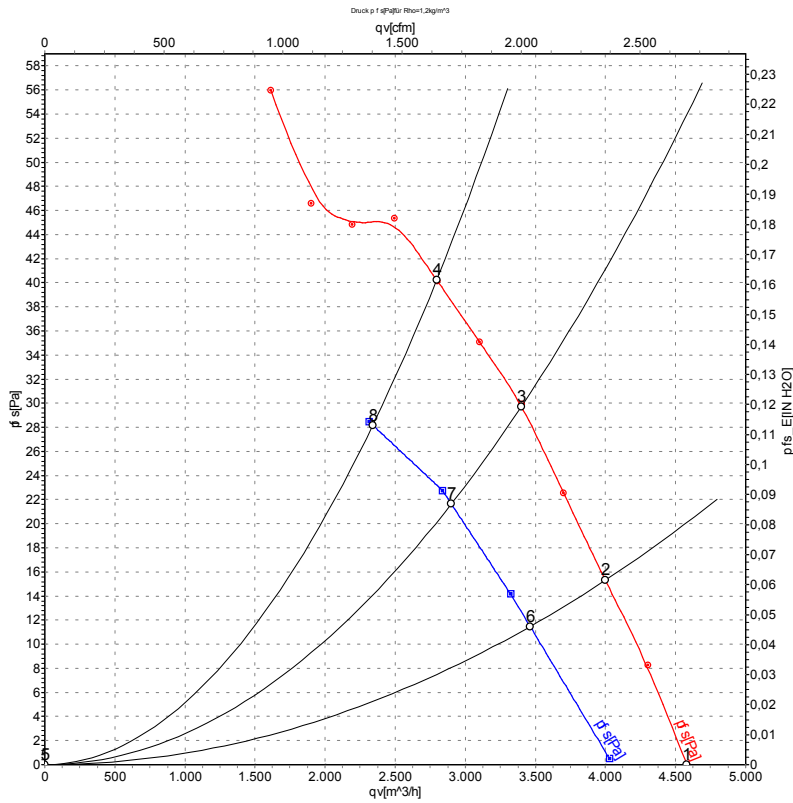

Measurement: LU-106642-1  
Measurement: LU-106797-1

Air performance measured according to ISO 5801 installation category A. For detailed information on the measurement setup, contact ebm-papst. Intake sound level: Sound power level according to ISO 13347 / sound pressure level measured at 1 m distance from fan axis. The values given are valid under the specified measuring conditions and may vary due to conditions of installation. For deviations from the standard configuration, the parameters have to be checked on the installed unit.

## Measured values

	Wired	U	f	n	P <sub>e</sub>	I	LpA <sub>in</sub>	LwA <sub>in</sub>	LwA <sub>out</sub>	qv	p <sub>fs</sub>	qv	p <sub>fs</sub>
		V	Hz	min <sup>-1</sup>	W	A	dB(A)	dB(A)	dB(A)	m <sup>3</sup> /h	Pa	CFM	inH2O
1	Δ	400	50	710	116	0.37	56	62	62	4580	0	2695	0.00
2	Δ	400	50	700	126	0.37	52	58	58	4000	15	2355	0.06
3	Δ	400	50	695	134	0.38	49	55	55	3400	30	2000	0.12
4	Δ	400	50	680	150	0.40	48	54	54	2795	40	1645	0.16
5	Y	400	50	630	72	0.14	54	60	60	4035	0	2375	0.00
6	Y	400	50	610	79	0.16	49	55	55	3460	12	2040	0.05
7	Y	400	50	590	85	0.16	45	51	51	2900	22	1705	0.09
8	Y	400	50	560	90	0.18	43	50	50	2340	28	1375	0.11

Wired = Wiring · U = Power supply · f = Frequency · n = Speed (rpm) · P<sub>e</sub> = Power consumption · I = Current draw · LpA<sub>in</sub> = Sound pressure level intake side · LwA<sub>in</sub> = Sound power level intake side  
LwA<sub>out</sub> = Sound power level outlet side · qv = Air flow · p<sub>fs</sub> = Pressure increase



# AC axial fan - HyBlade

sickle-shaped blades (S series)

with square full nozzle

## Curves: Air performance 60 Hz

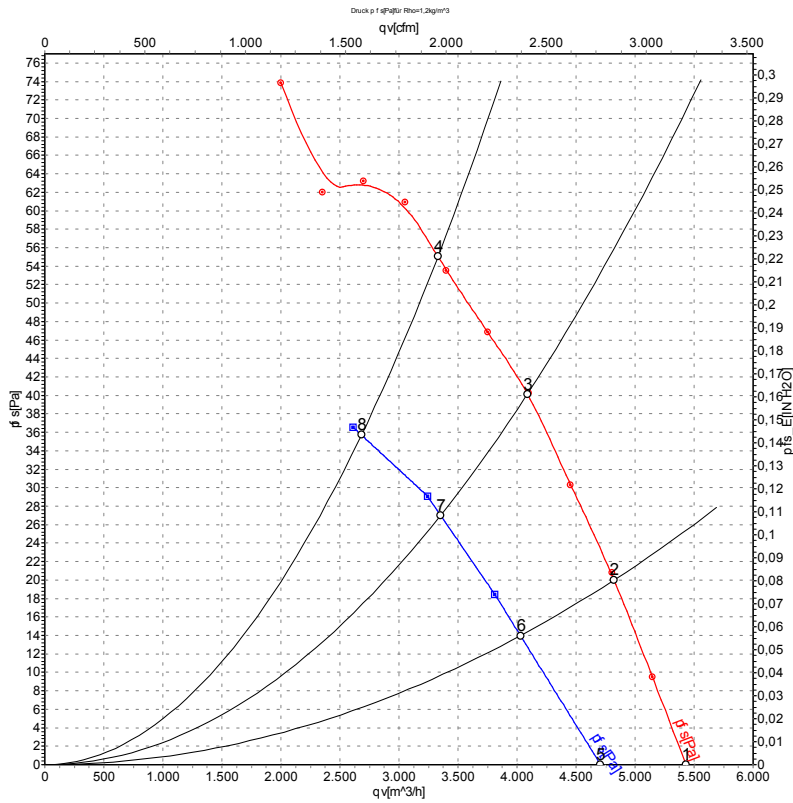

Measurement: LU-106643-1  
Measurement: LU-113765-1

Air performance measured according to ISO 5801 installation category A. For detailed information on the measurement setup, contact ebm-papst. Intake sound level: Sound power level according to ISO 13347 / sound pressure level measured at 1 m distance from fan axis. The values given are valid under the specified measuring conditions and may vary due to conditions of installation. For deviations from the standard configuration, the parameters have to be checked on the installed unit.

## Measured values

	Wired	U	f	n	P <sub>e</sub>	I	LpA <sub>in</sub>	LwA <sub>in</sub>	LwA <sub>out</sub>	qv	p <sub>fs</sub>	qv	p <sub>fs</sub>
		V	Hz	min <sup>-1</sup>	W	A	dB(A)	dB(A)	dB(A)	m <sup>3</sup> /h	Pa	CFM	inH <sub>2</sub> O
1	Δ	480	60	840	163	0.38	59	65	65	5430	0	3195	0.00
2	Δ	480	60	830	179	0.39	55	61	61	4820	20	2840	0.08
3	Δ	480	60	820	193	0.40	53	59	59	4090	40	2405	0.16
4	Δ	480	60	810	210	0.41	52	59	58	3330	55	1960	0.22
5	Y	480	60	725	108	0.17	56	62	62	4710	0	2770	0.00
6	Y	480	60	695	118	0.19	52	58	58	4030	14	2370	0.06
7	Y	480	60	670	127	0.20	48	54	54	3355	27	1975	0.11
8	Y	480	60	630	140	0.22	46	53	53	2685	36	1580	0.14

Wired = Wiring · U = Power supply · f = Frequency · n = Speed (rpm) · P<sub>e</sub> = Power consumption · I = Current draw · LpA<sub>in</sub> = Sound pressure level intake side · LwA<sub>in</sub> = Sound power level intake side  
LwA<sub>out</sub> = Sound power level outlet side · qv = Air flow · p<sub>fs</sub> = Pressure increase

