

W6E630-GN01-01 ebmpapst Datasheet

sales@fansco.com

www.fansco.com

Limited partnership · Headquarters Muldingen  
County court Stuttgart · HRA 590344General partner Elektrobau Muldingen GmbH · Headquarters Muldingen  
County court Stuttgart · HRB 590142

## Nominal data

Type	W6E630-GN01-01	
Motor	M6E110-GF	
Phase		1~
Nominal voltage	VAC	230
Frequency	Hz	50
Type of data definition		ml
Valid for approval / standard		CE
Speed	min <sup>-1</sup>	860
Power input	W	600
Current draw	A	2.62
Motor capacitor	µF	14
Capacitor voltage	VDB	400
Max. back pressure	Pa	100
Min. ambient temperature	°C	-40
Max. ambient temperature	°C	55

ml = max. load · me = max. efficiency · fa = running at free air · cs = customer specs · cu = customer unit  
Subject to alterations

## Data according to ErP directive

		Actual	Request 2013	Request 2015
Installation category	A			
Efficiency category	Static			
Variable speed drive	No			
Specific ratio*	1.00			
Overall efficiency $\eta_{es}$		32.2	28.2	32.2
Efficiency grade N		38.6	36	40
Power input $P_e$	kW	0.59		
Air flow $q_v$	m <sup>3</sup> /h	6725		
Pressure increase $p_{fs}$	Pa	98		
Speed n	min <sup>-1</sup>	865		

Data established at point of optimum efficiency

\* Specific ratio =  $1 + p_{fs} / 100\,000\text{ Pa}$ 

# AC axial fan - HyBlade®

sickled blades (S series)

with full square nozzle

## Technical features

<b>Mass</b>	27.4 kg
<b>Size</b>	630 mm
<b>Surface of rotor</b>	Coated in black
<b>Material of terminal box</b>	PP plastic
<b>Material of blades</b>	Press-fitted sheet steel blank, sprayed with PP plastic
<b>Material of wall ring</b>	Sheet steel, pre-galvanised and coated in black plastic (RAL 9005)
<b>Material of guard grille</b>	Steel, coated in black plastic (RAL9005)
<b>Number of blades</b>	5
<b>Direction of air flow</b>	"V"
<b>Direction of rotation</b>	Counter-clockwise, seen on rotor
<b>Type of protection</b>	IP 54
<b>Insulation class</b>	"F"
<b>Humidity class</b>	F4-1
<b>Max. permissible ambient motor temp. (transp./ storage)</b>	+ 80 °C
<b>Min. permissible ambient motor temp. (transp./storage)</b>	- 40 °C
<b>Mounting position</b>	Shaft horizontal or rotor on bottom; rotor on top on request
<b>Condensate discharge holes</b>	Rotor-side
<b>Operation mode</b>	S1
<b>Motor bearing</b>	Ball bearing
<b>Touch current acc. IEC 60990 (measuring network Fig. 4, TN system)</b>	<= 3.5 mA
<b>Electrical leads</b>	Via terminal box, integrated capacitor connected via terminal box
<b>Motor protection</b>	Thermal overload protector (TOP) brought out
<b>Cable exit</b>	Axial
<b>Protection class</b>	I (if protective earth is connected by customer)
<b>Product conforming to standard</b>	EN 61800-5-1; CE
<b>Approval</b>	GOST; VDE



# AC axial fan - HyBlade®

sickled blades (S series)

with full square nozzle

## Product drawing

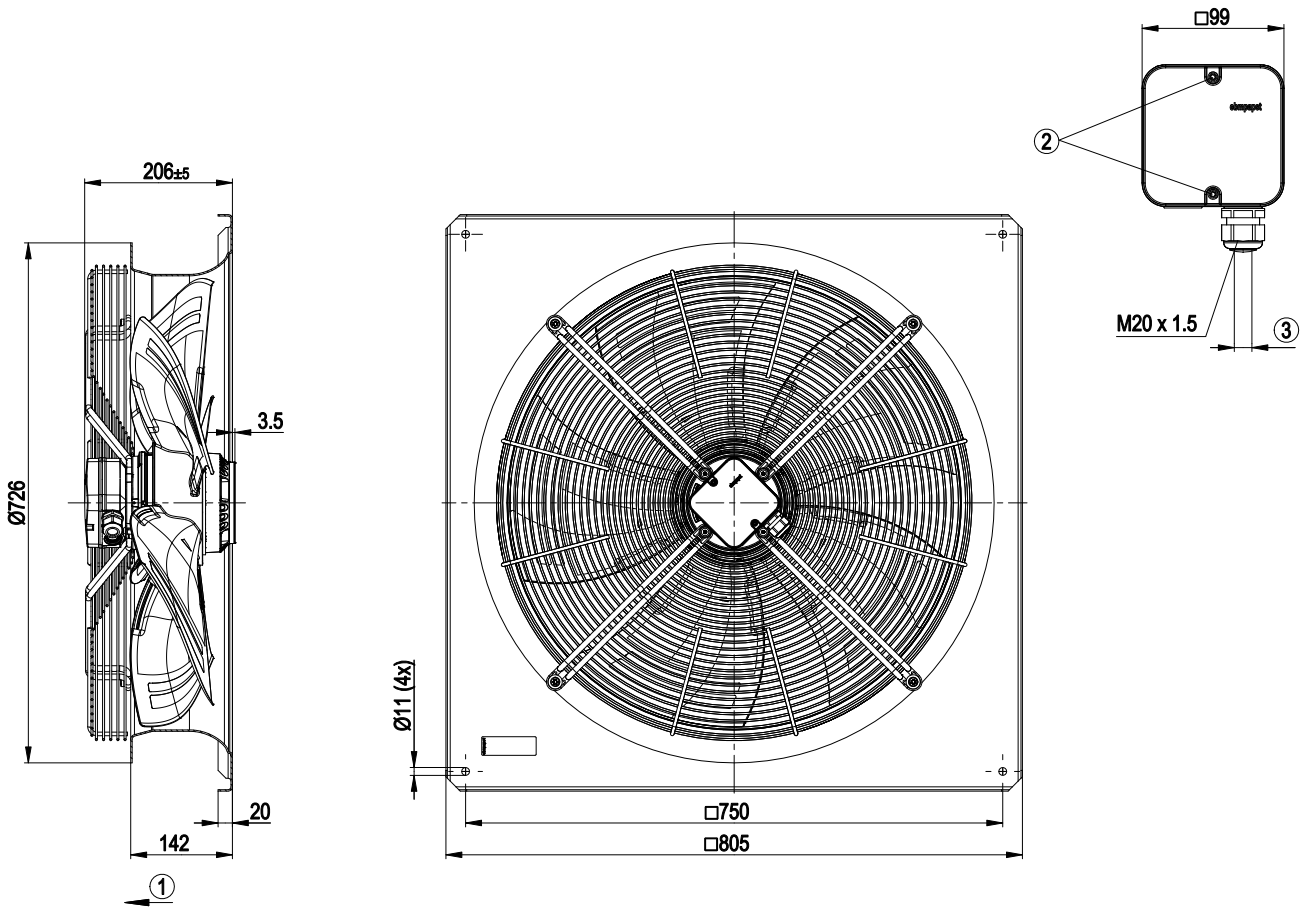

1	Direction of air flow "V"
2	Tightening torque 1.5±0.2 Nm
3	Cable diameter: min. 6 mm, max. 12 mm; tightening torque: 2±0.3 Nm



## Connection screen

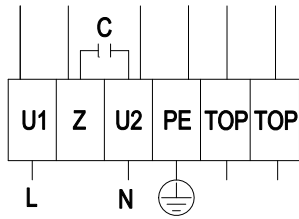

L	= U1 = blue	Z	brown	N	= U2 = black
PE	green / yellow	TOP	grey		

## Charts: Air flow 50 Hz

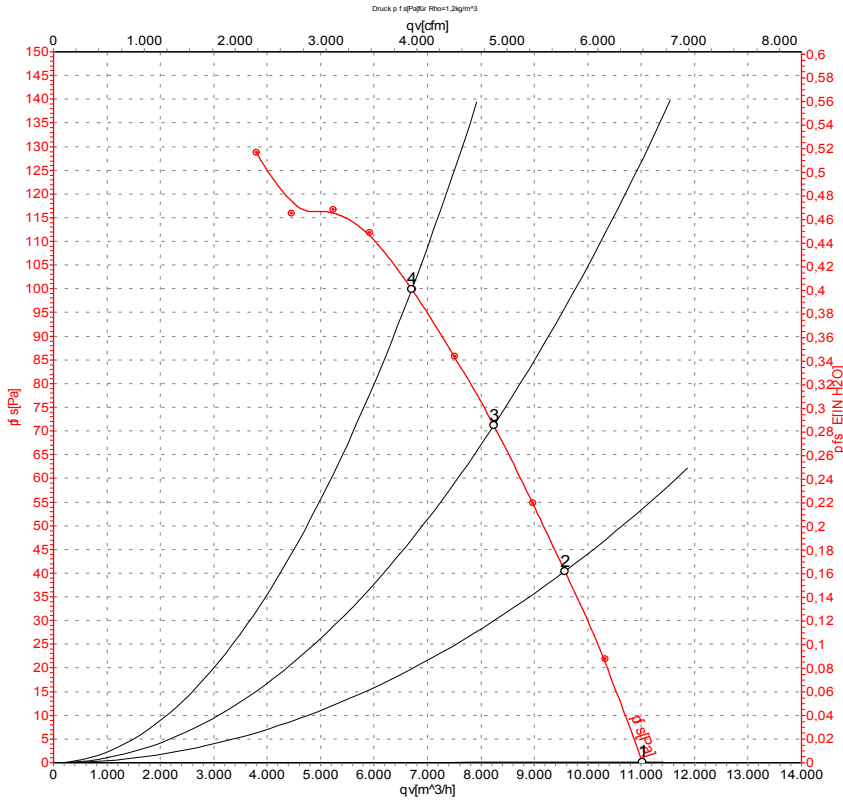

Measurement: LU-105789

Air performance measured as per ISO 5801 Installation category A. For detailed information on the measuring set-up, please contact ebmpapst. Suction-side noise levels: LwA measured as per ISO 13347 / LpA measured with 1m distance to fan axis. The values given are valid under the measuring conditions mentioned above and may vary according to the actual installation situation. With any deviation from the standard set-up, the specific values have to be checked and reviewed with the unit installed.

## Measured values

	U	f	n	Pe	I	LpA <sub>in</sub>	LwA <sub>in</sub>	LwA <sub>out</sub>	qv	p <sub>fs</sub>
	V	Hz	min <sup>-1</sup>	W	A	dB(A)	dB(A)	dB(A)	m <sup>3</sup> /h	Pa
1	230	50	925	467	2.04	64	70	70	11020	0
2	230	50	905	521	2.27	61	67	67	9570	40
3	230	50	885	559	2.44	60	66	65	8240	70
4	230	50	860	600	2.62	61	68	67	6705	100

U = Supply voltage · f = Frequency · n = Speed · Pe = Power input · I = Current draw · LpA<sub>in</sub> = Sound pressure level inlet side · LwA<sub>in</sub> = Sound power level inlet side · LwA<sub>out</sub> = Sound power level outlet side  
 qv = Air flow · p<sub>fs</sub> = Pressure increase

