

AC axial fan - HyBlade

sickle-shaped blades (S series)

with square full nozzle

W6E500-DJ05-04 ebmpapst Datasheet

sales@fansco.com

www.fansco.com

Limited partnership · Headquarters Mulfingen

Amtsgericht (court of registration) Stuttgart · HRA 590344

General partner Elektrobau Mulfingen GmbH · Headquarters Mulfingen

Amtsgericht (court of registration) Stuttgart · HRB 590142

Nominal data

Type	W6E500-DJ05-04		
Motor	M6E110-EF		
Phase		1~	1~
Nominal voltage	VAC	230	230
Frequency	Hz	50	60
Method of obtaining data		ml	ml
Valid for approval/standard		CE	CE
Speed (rpm)	min ⁻¹	865	810
Power consumption	W	220	290
Current draw	A	0.97	1.3
Capacitor	µF	5	5
Capacitor voltage	VDB	400	400
Max. back pressure	Pa	60	57
Max. back pressure	inH ₂ O	0.24	0.23
Min. ambient temperature	°C	-40	-40
Max. ambient temperature	°C	80	70
Starting current	A	1.7	1.51

ml = Max. load · me = Max. efficiency · fa = Free air · cs = Customer specification · ce = Customer equipment
Subject to change

Data according to ErP Directive

		Actual	Req. 2015			
01 Overall efficiency η_{es}	%	29.4	29.4	09 Power consumption P_e	kW	0.21
02 Measurement category		A		09 Air flow q_v	m ³ /h	3940
03 Efficiency category		Static		09 Pressure increase p_{fs}	Pa	56
04 Efficiency grade N		40	40	10 Speed (rpm) n	min ⁻¹	870
05 Variable speed drive		No		11 Specific ratio*		1.00

Data obtained at optimum efficiency level.

The ErP data is determined using a motor-impeller combination in a standardized measurement setup.

* Specific ratio = $1 + p_{fs} / 100\,000\text{ Pa}$

LU-136414



AC axial fan - HyBlade

sickle-shaped blades (S series)

with square full nozzle

Technical description

Weight	15 kg
Fan size	500 mm
Rotor surface	Painted black
Terminal box material	PC/ABS plastic
Blade material	Press-fitted sheet steel blank, sprayed with PP plastic
Fan housing material	Sheet steel, pre-galvanized and coated with black plastic
Guard grille material	Steel, phosphated and coated with black plastic
Number of blades	5
Airflow direction	"A"
Direction of rotation	Clockwise, viewed toward rotor
Degree of protection	IP54
Insulation class	"F"
Moisture (F) / Environmental (H) protection class	F4-1
Max. permitted ambient temp. for motor (transport/storage)	+ 80 °C
Min. permitted ambient temp. for motor (transport/storage)	- 40 °C
Installation position	Shaft horizontal or rotor on bottom
Condensation drainage holes	On rotor side
Mode	S1
Motor bearing	Ball bearing
Touch current according to IEC 60990 (measuring circuit Fig. 4, TN system)	<= 3.5 mA
Electrical hookup	Via terminal box, capacitor integrated and connected
Motor protection	Thermal overload protector (TOP) with basic insulation
Protection class	I (with customer connection of protective earth)
Motor capacitor according to EN 60252-1 in safety protection class	S0
Conformity with standards	EN 61800-5-1; CE
Approval	CSA C22.2 No. 100; UL 1004-1; VDE



AC axial fan - HyBlade

sickle-shaped blades (S series)

with square full nozzle

Product drawing

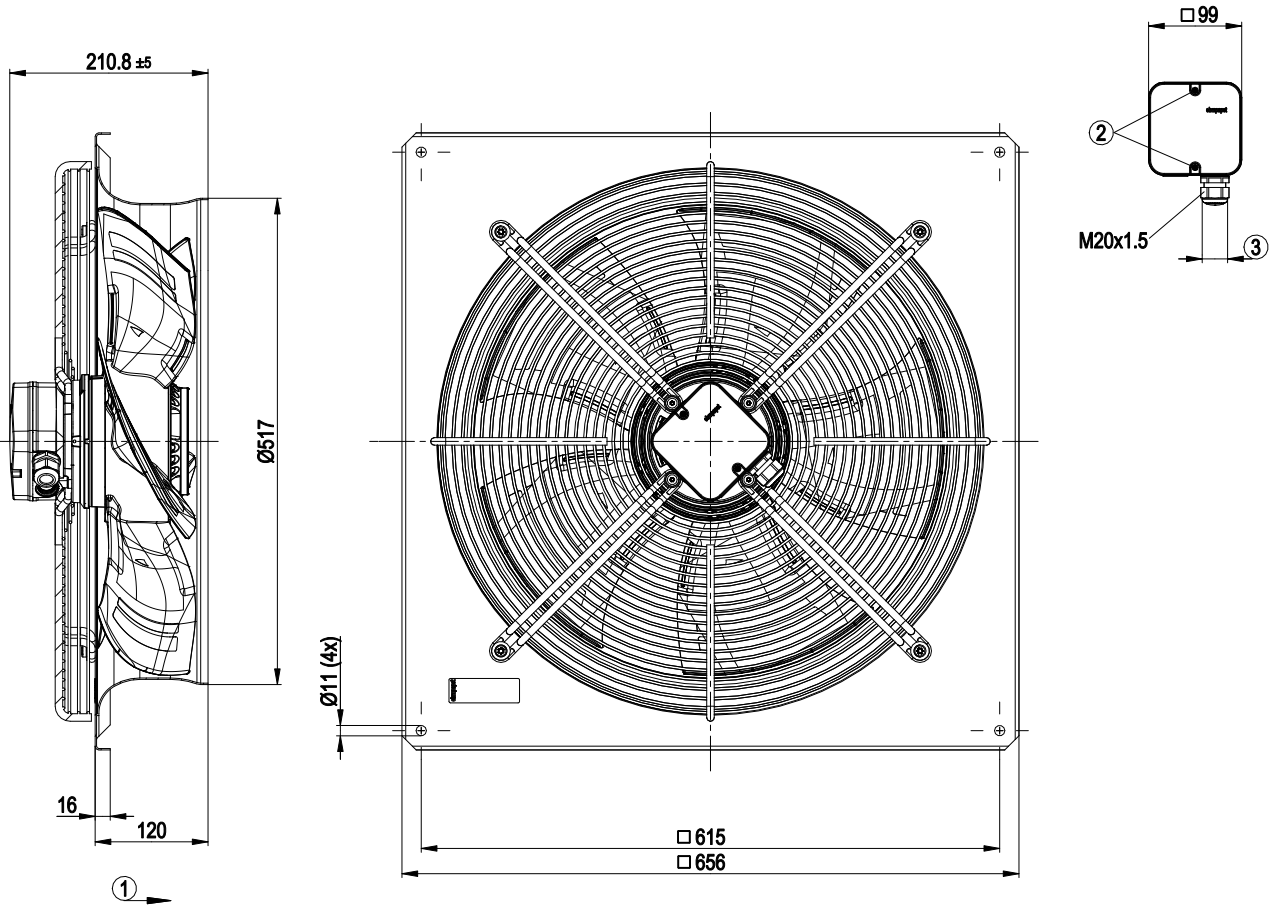

1	Direction of air flow "A"
2	Tightening torque 1.5 ± 0.2 Nm
3	Cable diameter: min. 6 mm, max. 12 mm; tightening torque 2 ± 0.3 Nm



AC axial fan - HyBlade

sickle-shaped blades (S series)

with square full nozzle

Connection diagram

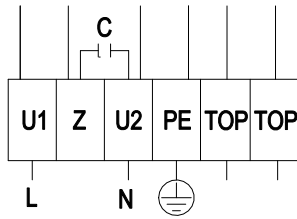

L	= U1 = blue	Z	brown	N	= U2 = black
PE	green/yellow	TOP	gray		



AC axial fan - HyBlade

sickle-shaped blades (S series)

with square full nozzle

Curves: Air performance 50 Hz

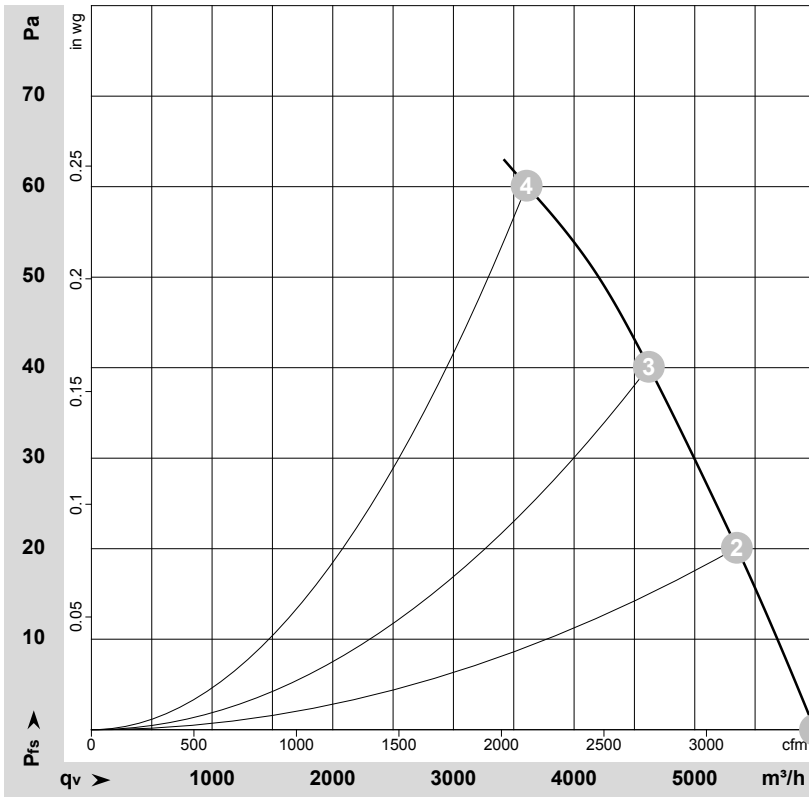

$\rho = 1.15 \text{ kg/m}^3 \pm 2 \%$

Measurement: LU-136414-1

Air performance measured according to ISO 5801 installation category A. For detailed information on the measurement setup, contact ebmpapst. Intake sound level: Sound power level according to ISO 13347 / sound pressure level measured at 1 m distance from fan axis. The values given are valid under the specified measuring conditions and may vary due to conditions of installation. For deviations from the standard configuration, the parameters have to be checked on the installed unit.

Measured values

	U	f	n	P _e	I	LpA _{in}	LwA _{in}	LwA _{out}	q _v	P _{fs}	q _v	P _{fs}
	V	Hz	min ⁻¹	W	A	dB(A)	dB(A)	dB(A)	m ³ /h	Pa	cfm	inH ₂ O
1	230	50	915	175	0.76	60	66	66	5995	0	3530	0.00
2	230	50	900	190	0.83	57	64	64	5350	20	3150	0.08
3	230	50	885	204	0.89	55	62	62	4620	40	2720	0.16
4	230	50	865	220	0.97	54	61	60	3605	60	2125	0.24

U = Power supply · f = Frequency · n = Speed (rpm) · P_e = Power consumption · I = Current draw · LpA_{in} = Sound pressure level intake side · LwA_{in} = Sound power level intake side
 LwA_{out} = Sound power level outlet side · q_v = Air flow · P_{fs} = Pressure increase



AC axial fan - HyBlade

sickle-shaped blades (S series)

with square full nozzle

Curves: Air performance 60 Hz

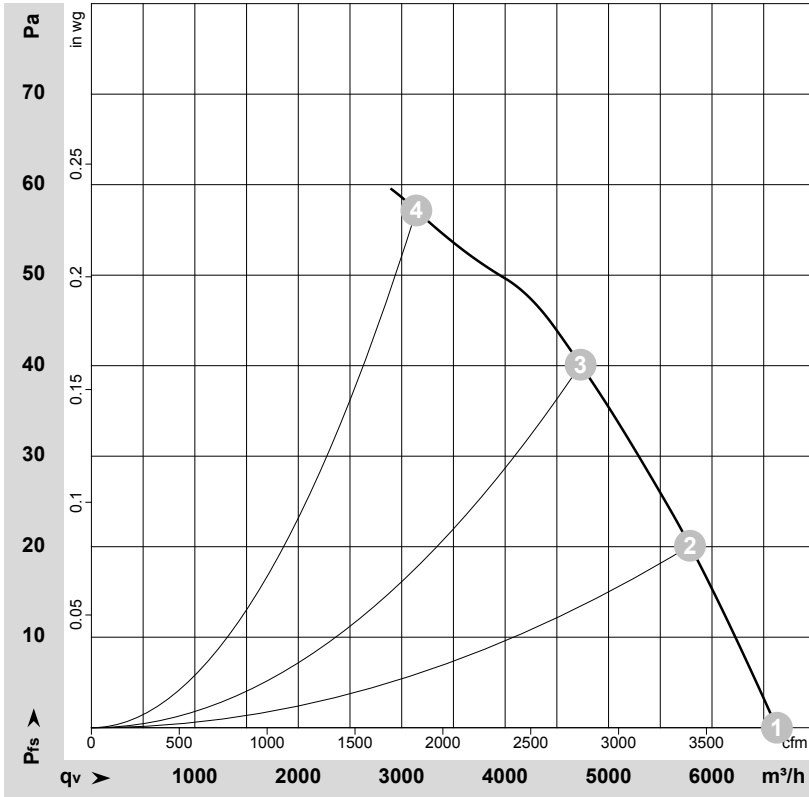

$\rho = 1.15 \text{ kg/m}^3 \pm 2 \%$

Measurement: LU-136419-1

Air performance measured according to ISO 5801 installation category A. For detailed information on the measurement setup, contact ebmpapst. Intake sound level: Sound power level according to ISO 13347 / sound pressure level measured at 1 m distance from fan axis. The values given are valid under the specified measuring conditions and may vary due to conditions of installation. For deviations from the standard configuration, the parameters have to be checked on the installed unit.

Measured values

	U	f	n	P _e	I	LpA _{in}	LwA _{in}	LwA _{out}	q _v	P _{fs}	q _v	P _{fs}
	V	Hz	min ⁻¹	W	A	dB(A)	dB(A)	dB(A)	m ³ /h	Pa	cfm	inH ₂ O
1	230	60	1010	255	1.11	62	69	68	6630	0	3900	0.00
2	230	60	965	268	1.17	59	66	65	5785	20	3405	0.08
3	230	60	900	280	1.24	56	63	63	4730	40	2785	0.16
4	230	60	810	290	1.30	54	61	61	3140	57	1850	0.23

U = Power supply · f = Frequency · n = Speed (rpm) · P_e = Power consumption · I = Current draw · LpA_{in} = Sound pressure level intake side · LwA_{in} = Sound power level intake side
 LwA_{out} = Sound power level outlet side · q_v = Air flow · P_{fs} = Pressure increase

