

# AC axial fan - HyBlade

sickle-shaped blades (S series)

Fan housing with guard grille

W6E350-CN24-30 ebmpapst Datasheet

sales@fansco.com

www.fansco.com

Limited partnership · Headquarters Muldingen

Amtsgericht (court of registration) Stuttgart · HRA 590344

General partner Elektrobau Muldingen GmbH · Headquarters Muldingen

Amtsgericht (court of registration) Stuttgart · HRB 590142

## Nominal data

Type	W6E350-CN24-30				
Motor	M6E074-DF				
Phase		1~	1~	1~	1~
Nominal voltage	VAC	230	230	240	240
Frequency	Hz	50	60	50	60
Method of obtaining data		ml	ml	ml	ml
Valid for approval/standard		CE	CE	CE	CE
Speed (rpm)	min <sup>-1</sup>	910	1020	910	1040
Power consumption	W	75	95	80	96
Current draw	A	0.35	0.42	0.36	0.41
Capacitor	µF	2	2	2	2
Capacitor voltage	VDB	400	400	450	450
Capacitor standard		S0 (CE)	S0 (CE)	S0 (CE)	S0 (CE)
Max. back pressure	Pa	40	50	40	53
Max. back pressure	inH <sub>2</sub> O	0.16	0.2	0.16	0.21
Min. ambient temperature	°C	-25	-25	-25	-25
Max. ambient temperature	°C	50	55	50	55
Starting current	A	0.56	0.51	0.57	0.52

ml = Max. load · me = Max. efficiency · fa = Free air · cs = Customer specification · ce = Customer equipment  
Subject to change



# AC axial fan - HyBlade

sickle-shaped blades (S series)

Fan housing with guard grille

## Technical description

Weight	6.5 kg
Fan size	350 mm
Rotor surface	Painted black
Blade material	Press-fitted sheet steel blank, sprayed with PP plastic
Fan housing material	Sheet steel, galvanized and coated with black plastic (RAL 9005)
Guard grille material	Steel, coated with black plastic (RAL 9005)
Number of blades	5
Airflow direction	"V"
Direction of rotation	Counterclockwise, viewed toward rotor
Degree of protection	IP44; installation- and position-dependent as per EN 60034-5
Insulation class	"B"
Moisture (F) / Environmental (H) protection class	H0+
Max. permitted ambient temp. for motor (transport/storage)	+ 80 °C
Min. permitted ambient temp. for motor (transport/storage)	- 40 °C
Installation position	Shaft horizontal or rotor on bottom; rotor on top on request
Condensation drainage holes	On rotor side
Mode	S1
Motor bearing	Ball bearing
Touch current according to IEC 60990 (measuring circuit Fig. 4, TN system)	< 0.75 mA
Motor protection	Thermal overload protector (TOP) internally connected
With cable	Variable
Protection class	I (with customer connection of protective earth)
Conformity with standards	EN 60335-1; CE
Approval	CCC



# AC axial fan - HyBlade

sickle-shaped blades (S series)

Fan housing with guard grille

## Product drawing

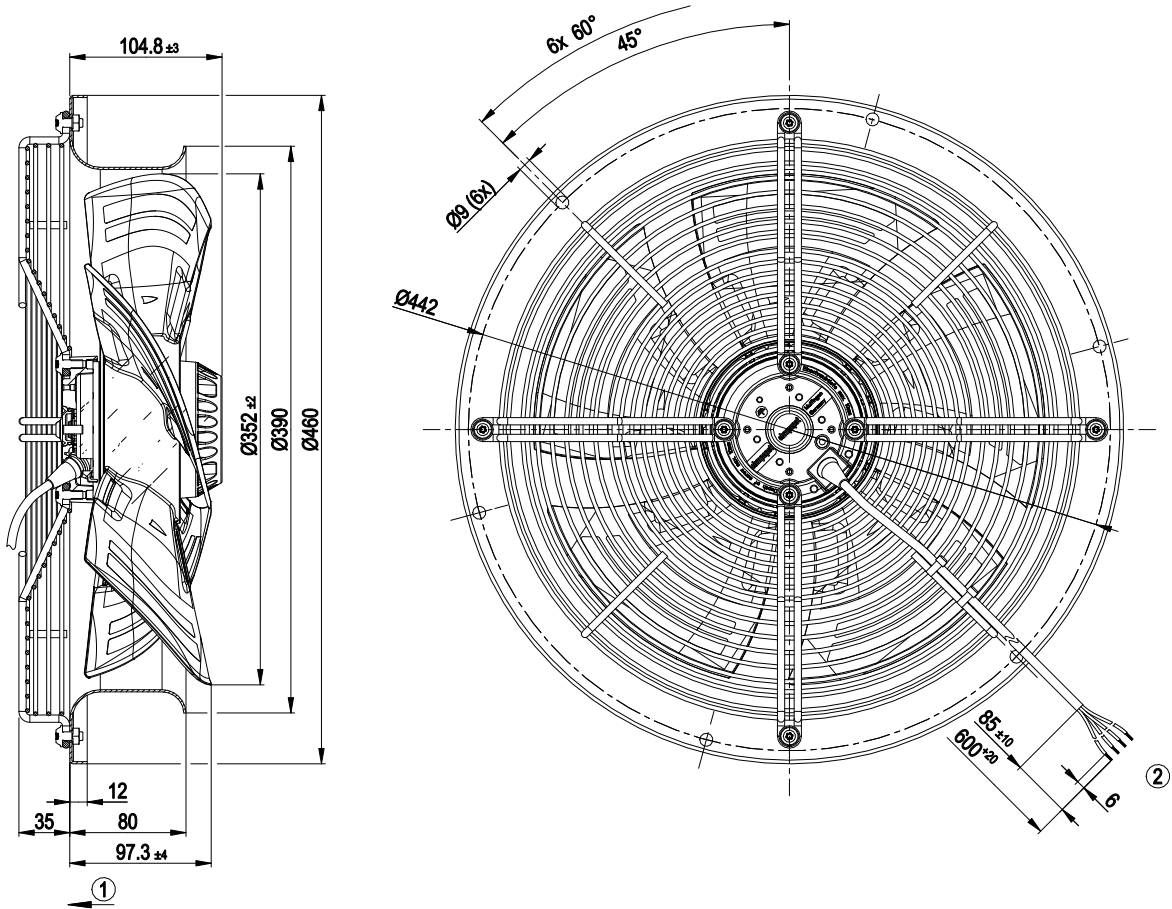

- |   |  |
|---|--|
| 1 | Direction of air flow "V"                                  |
| 2 | Cable silicone 4G 0.5 mm <sup>2</sup> , 4x crimped splices |

## Connection diagram

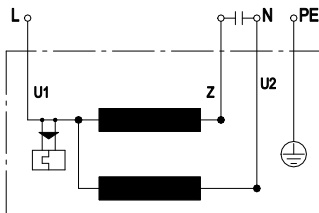

U1	blue	Z	brown	U2	black
PE	green/yellow				



# AC axial fan - HyBlade

sickle-shaped blades (S series)

Fan housing with guard grille

## Curves: Air performance 50 Hz

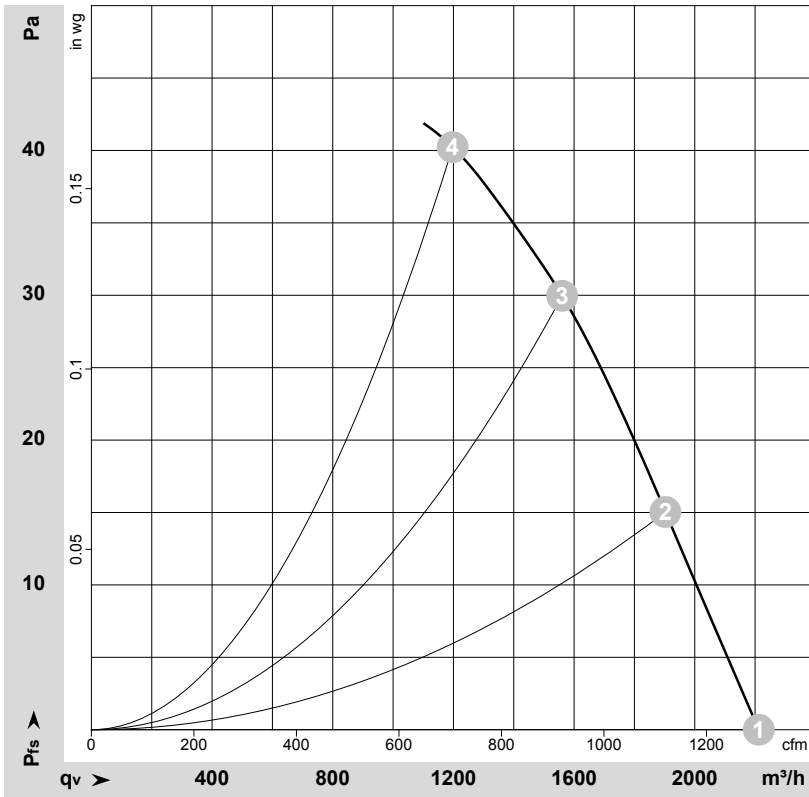

$\rho = 1.15 \text{ kg/m}^3 \pm 2 \%$

Measurement: LU-131056-1

Air performance measured according to ISO 5801 installation category A. For detailed information on the measurement setup, contact ebm-papst. Intake sound level: Sound power level according to ISO 13347 / sound pressure level measured at 1 m distance from fan axis. The values given are valid under the specified measuring conditions and may vary due to conditions of installation. For deviations from the standard configuration, the parameters have to be checked on the installed unit.

## Measured values

	U	f	n	P <sub>e</sub>	I	LpA <sub>in</sub>	LwA <sub>in</sub>	q <sub>v</sub>	p <sub>fs</sub>	q <sub>v</sub>	p <sub>fs</sub>
	V	Hz	min <sup>-1</sup>	W	A	dB(A)	dB(A)	m <sup>3</sup> /h	Pa	cfm	inH <sub>2</sub> O
1	230	50	935	67	0.33	51	59	2210	0	1300	0.00
2	230	50	925	70	0.33	49	57	1905	15	1120	0.06
3	230	50	915	72	0.34	46	54	1560	30	920	0.12
4	230	50	910	75	0.35	45	53	1195	40	705	0.16

U = Power supply · f = Frequency · n = Speed (rpm) · P<sub>e</sub> = Power consumption · I = Current draw · LpA<sub>in</sub> = Sound pressure level intake side · LwA<sub>in</sub> = Sound power level intake side  
 q<sub>v</sub> = Air flow · p<sub>fs</sub> = Pressure increase



# AC axial fan - HyBlade

sickle-shaped blades (S series)

Fan housing with guard grille

## Curves: Air performance 60 Hz

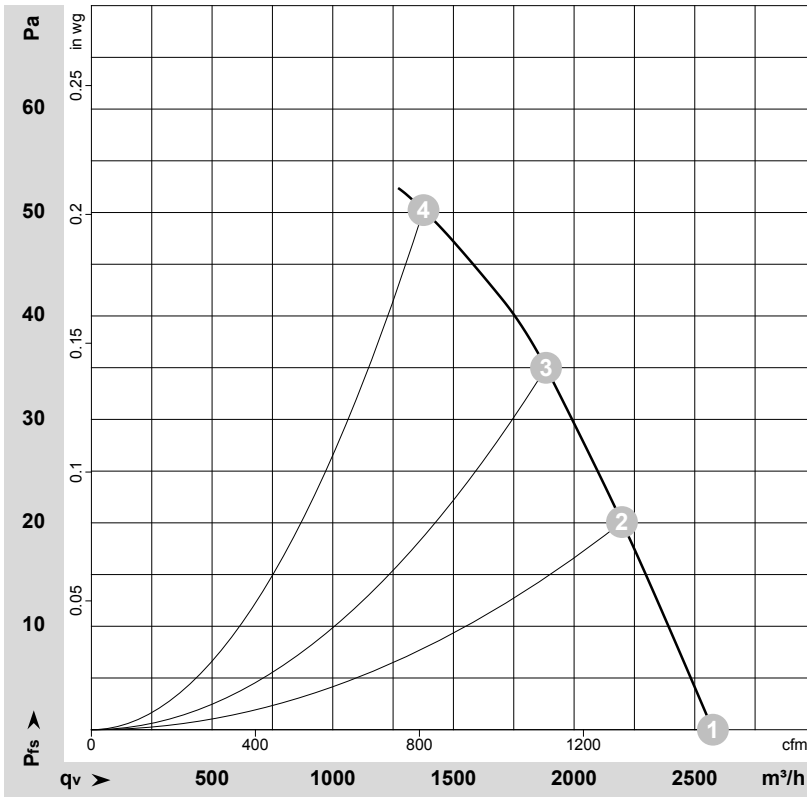

$\rho = 1.15 \text{ kg/m}^3 \pm 2 \%$

Measurement: LU-131059-1

Air performance measured according to ISO 5801 installation category A. For detailed information on the measurement setup, contact ebmpapst. Intake sound level: Sound power level according to ISO 13347 / sound pressure level measured at 1 m distance from fan axis. The values given are valid under the specified measuring conditions and may vary due to conditions of installation. For deviations from the standard configuration, the parameters have to be checked on the installed unit.

## Measured values

	U	f	n	P <sub>e</sub>	I	LpA <sub>in</sub>	LwA <sub>in</sub>	q <sub>v</sub>	p <sub>fs</sub>	q <sub>v</sub>	p <sub>fs</sub>
	V	Hz	min <sup>-1</sup>	W	A	dB(A)	dB(A)	m <sup>3</sup> /h	Pa	cfm	inH <sub>2</sub> O
1	230	60	1095	83	0.36	55	62	2575	0	1515	0.00
2	230	60	1070	87	0.38	53	60	2200	20	1295	0.08
3	230	60	1050	90	0.39	50	57	1885	35	1110	0.14
4	230	60	1020	95	0.42	48	56	1375	50	810	0.20

U = Power supply · f = Frequency · n = Speed (rpm) · P<sub>e</sub> = Power consumption · I = Current draw · LpA<sub>in</sub> = Sound pressure level intake side · LwA<sub>in</sub> = Sound power level intake side  
 q<sub>v</sub> = Air flow · p<sub>fs</sub> = Pressure increase

