

W6D990-CX01-83 ebmpapst Datasheet FansCo

sales@fansco.com

www.fansco.com

## Nominal data

Type	W6D990-CX01-83	
Motor	M6D138-OA	
Phase		3~
Nominal voltage	VAC	400
Connection		Y
Frequency	Hz	50
Type of data definition		fa
Valid for approval / standard		CE
Speed	min <sup>-1</sup>	950
Power input	W	1690
Current draw	A	4.4
Max. back pressure	Pa	145
Max. ambient temperature	°C	60
Starting current	A	20.0

ml = Max. load · me = Max. efficiency · fa = Running at free air · cs = Customer specs · cu = Customer unit  
Subject to alterations

## Data according to ErP directive

		Actual	Request 2013	Request 2015
Installation category	A			
Efficiency category	Static			
Variable speed drive	No			
Specific ratio*	1.00			
Overall efficiency $\eta_{es}$	%	39.8	32.2	36.2
Efficiency grade N		43.6	36	40
Power input $P_e$	kW	2.56		
Air flow $q_v$	m <sup>3</sup> /h	22085		
Pressure increase $p_{fs}$	Pa	167		
Speed n	min <sup>-1</sup>	920		

Data definition with optimum efficiency. LU-114362  
The ErP data is determined using a motor-impeller combination in a standardised measurement configuration.



## AC axial fan - HyBlade®

sickled blades (S series)

In-line duct fan, Transformator fan

## Technical features

Mass	60.7 kg
Size	990 mm
Material of blades	Aluminium sheet insert, sprayed with PP plastic
Material of wall ring	Sheet steel, pre-galvanised and plastic-coated in white aluminium (RAL 9006)
Material of guard grille	Steel, coated in white aluminium plastic (RAL 9006)
Number of blades	5
Blade angle	-5°
Direction of air flow	"A"
Direction of rotation	Counter-clockwise, seen on rotor
Type of protection	IP 54
Insulation class	"F"
Humidity class	F4-2
Max. permissible ambient motor temp. (transp./ storage)	+80 °C
Min. permissible ambient motor temp. (transp./storage)	-40 °C
Mounting position	Shaft horizontal or rotor on bottom
Condensate discharge holes	On the stator side
Operation mode	S1
Motor bearing	Ball bearing
Touch current acc. IEC 60990 (measuring network Fig. 4, TN system)	<= 3.5 mA
Electrical leads	Via terminal box
Motor protection	Thermal overload protector (TOP) brought out
Protection class	I (if protective earth is connected by customer)
Product conforming to standard	EN 61800-5-1; EN 60034; CE
Approval	EAC



# AC axial fan - HyBlade®

sickled blades (S series)

In-line duct fan, Transformator fan

## Product drawing

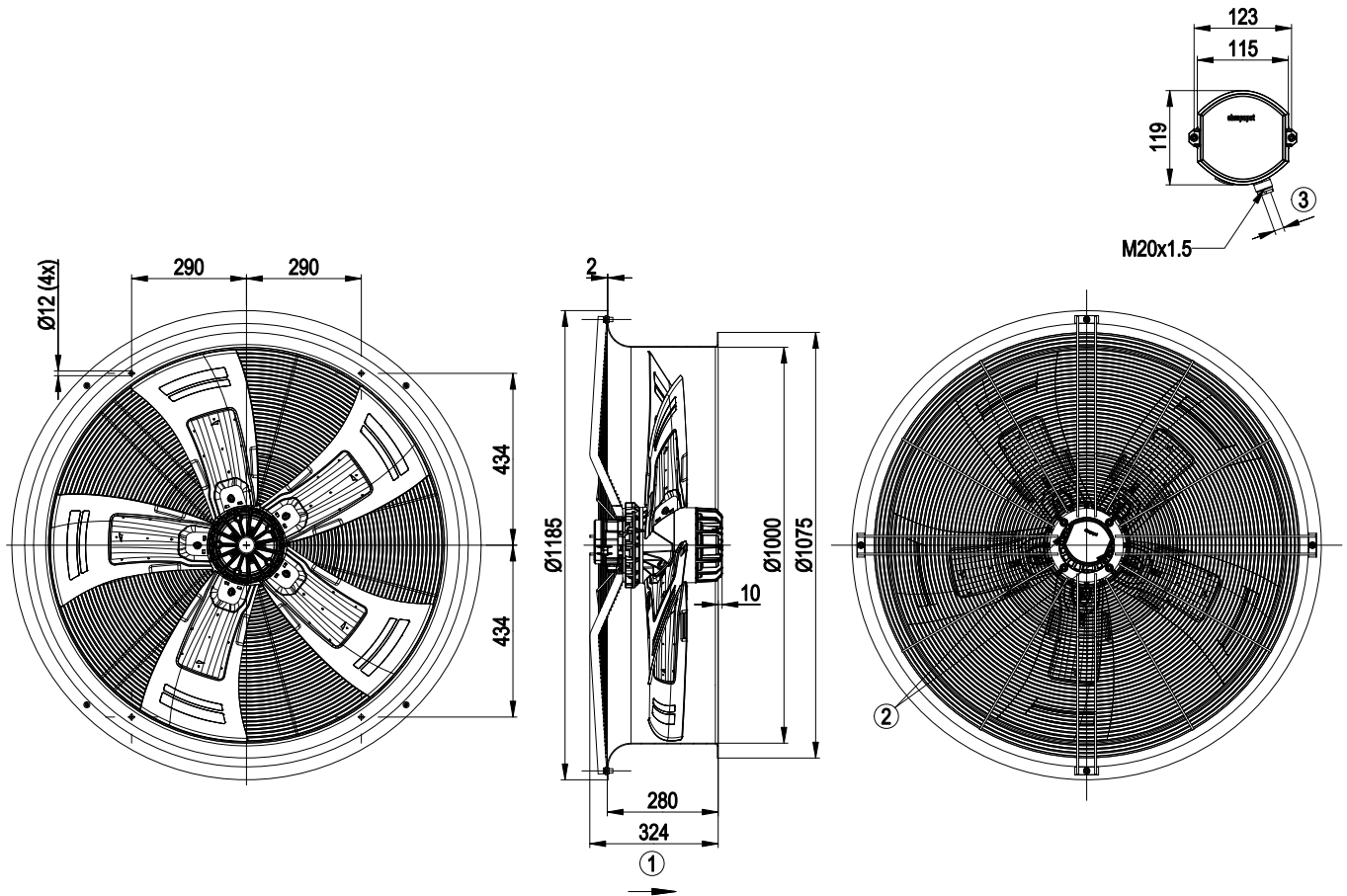

1	Direction of air flow "A"
2	Tightening torque 2.5 Nm ± 0.4 Nm
3	Cable diameter min. 10 mm, max. 12 mm, tightening torque 2.5 Nm ± 0.3Nm



# AC axial fan - HyBlade®

sickled blades (S series)

In-line duct fan, Transformator fan

## Connection screen

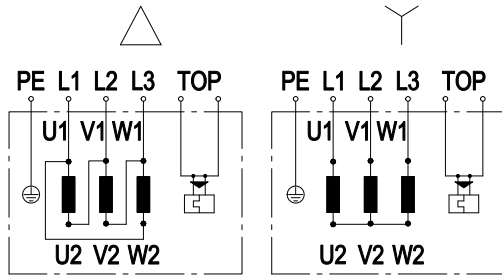

Δ	Delta connection	Y	Star connection	L1	black
L2	blue	L3	brown	U1	black
V1	blue	W1	brown	U2	green
V2	white	W2	yellow	TOP	2xgrey
PE	green/yellow				



## Charts: Air flow 50 Hz

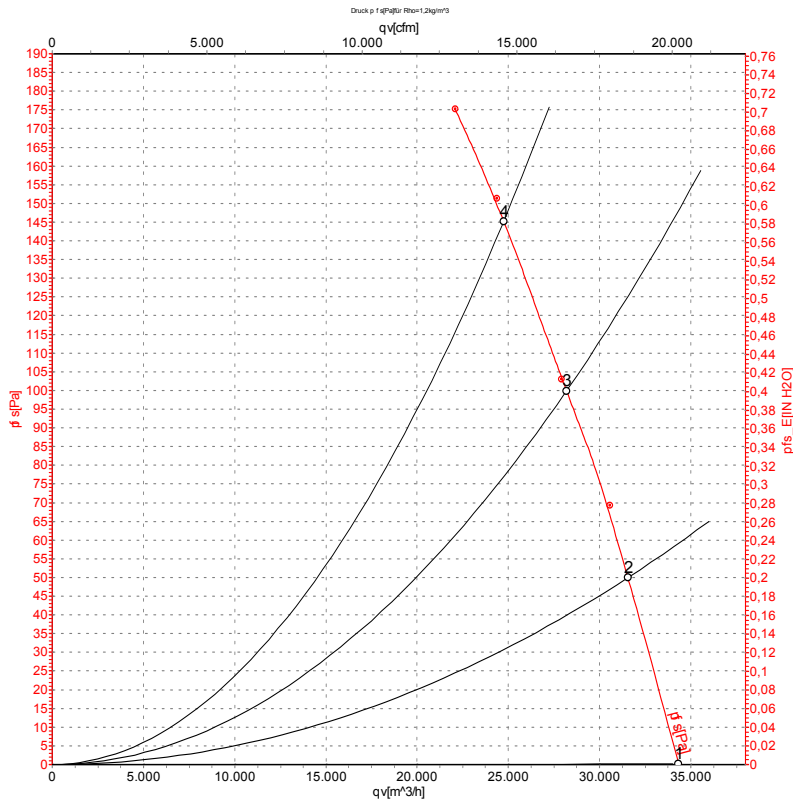

Air performance measured as per ISO 5801 Installation category A. For detailed information on the measuring set-up, please contact ebmpapst. Suction-side noise levels: LwA measured as per ISO 13347 / LpA measured with 1m distance to fan axis. The values given are valid under the measuring conditions mentioned above and may vary according to the actual installation situation. With any deviation from the standard set-up, the specific values have to be checked and reviewed with the unit installed.

## Measured values

	Conn.	U	f	n	P <sub>e</sub>	I	LpA <sub>in</sub>	LwA <sub>in</sub>	LwA <sub>out</sub>	qv	p <sub>fs</sub>
		V	Hz	min <sup>-1</sup>	W	A	dB(A)	dB(A)	dB(A)	m <sup>3</sup> /h	Pa
1	Y	400	50	950	1690	4.40	76	83	84	34330	0
2	Y	400	50	940	1963	4.70	75	82	83	31560	50
3	Y	400	50	935	2239	5.03	75	82	82	28190	100
4	Y	400	50	925	2480	5.37	75	82	83	24750	145

Conn. = Connection · U = Supply voltage · f = Frequency · n = Speed · P<sub>e</sub> = Power input · I = Current draw · LpA<sub>in</sub> = Sound pressure level inlet side · LwA<sub>in</sub> = Sound power level inlet side  
 LwA<sub>out</sub> = Sound power level outlet side · qv = Air flow · p<sub>fs</sub> = Pressure increase

