

sickle-shaped blades (S series)

with square full nozzle

ebm-papst Ventilator (Shanghai) Co.,Ltd.No.418, Hua Jing Road, Pilot Free Trade Zone, Pudong District,
Shanghai, China, 200131W6D910-KD01-01/F02 ebmpapst Datasheet
sales@fansco.com
www.fansco.com**Nominal data**

Type	W6D910-KD01-01/F02		
Motor	M6D138-LA		
Phase		3~	3~
Nominal voltage	VAC	400	400
Wiring		Δ	Y
Frequency	Hz	50	50
Method of obtaining data		ml	ml
Valid for approval/standard		CE	CE
Speed (rpm)	min ⁻¹	870	640
Power consumption	W	1920	1170
Current draw	A	3.8	2.2
Max. back pressure	Pa	170	95
Max. back pressure	in. wg	0.68	0.38
Min. ambient temperature	°C	-40	-40
Max. ambient temperature	°C	55	55
Starting current	A	13	4.3

ml = Max. load · me = Max. efficiency · fa = Free air · cs = Customer specification · ce = Customer equipment
Subject to change**Data according to Commission Regulation (EU) 327/2011 (EN 17166)**

		Actual	Req. 2015			
01 Overall efficiency η_{es}	%	41.9	35.1	09 Power consumption P_e	kW	1.68
02 Measurement category		A		09 Air flow q_v	m ³ /h	18355
03 Efficiency category		Static		09 Pressure increase p_{fs}	Pa	139
04 Efficiency grade N		46.8	40	10 Speed (rpm) n	min ⁻¹	900
05 Variable speed drive		No		11 Specific ratio*		1.00

Data obtained at optimum efficiency level.

* Specific ratio = $1 + p_{fs} / 100\,000\text{ Pa}$

LU-192850

The efficiency values displayed for achieving conformity with the Ecodesign Regulation EU 327/2011 has been reached with defined air duct components (e.g. inlet rings).
The dimensions must be requested from ebm-papst. If other air conduction geometries are used on the installation side, the ebm-papst evaluation loses its validity/the conformity must be confirmed again.
The product does not fall within the scope of Regulation (EU) 2019/1781 due to the exception specified in Article 2 (2a) (motors completely integrated into a product).

Technical description

Weight	53.4 kg
Size	910 mm
Motor size	138
Rotor surface	Cast in aluminum
Terminal box material	PP plastic
Blade material	PP plastic
Fan housing material	Sheet steel, galvanized and coated with stone grey plastic (RAL 7030)
Guard grille material	Steel, coated with black plastic (RAL 9005)
Number of blades	5
Blade pitch	0°
Airflow direction	V
Direction of rotation	Clockwise, viewed toward rotor
Degree of protection	IP54
Insulation class	"F"
Moisture (F) / Environmental (H) protection class	H2
Ambient temperature note	Occasional start-up at temperatures between -40°C and -25°C is permitted. For continuous operation at ambient temperatures below -25°C (such as refrigeration applications), use must be made of a fan design with special low-temperature bearings.
Max. permitted ambient temp. for motor (transport/storage)	+80 °C
Min. permitted ambient temp. for motor (transport/storage)	-40 °C
Installation position	Any
Condensation drainage holes	On rotor and stator sides
Mode	S1
Motor bearing	Ball bearing
Touch current according to IEC 60990 (measuring circuit Fig. 4, TN system)	<= 3.5 mA
Electrical hookup	Terminal box
Motor protection	Thermal overload protector (TOP) with basic insulation
Protection class	I (with customer connection of protective earth)
Conformity with standards	EN 60034-1 ; CE

AC axial fan - AxiBlade

sickle-shaped blades (S series)

with square full nozzle

Product drawing

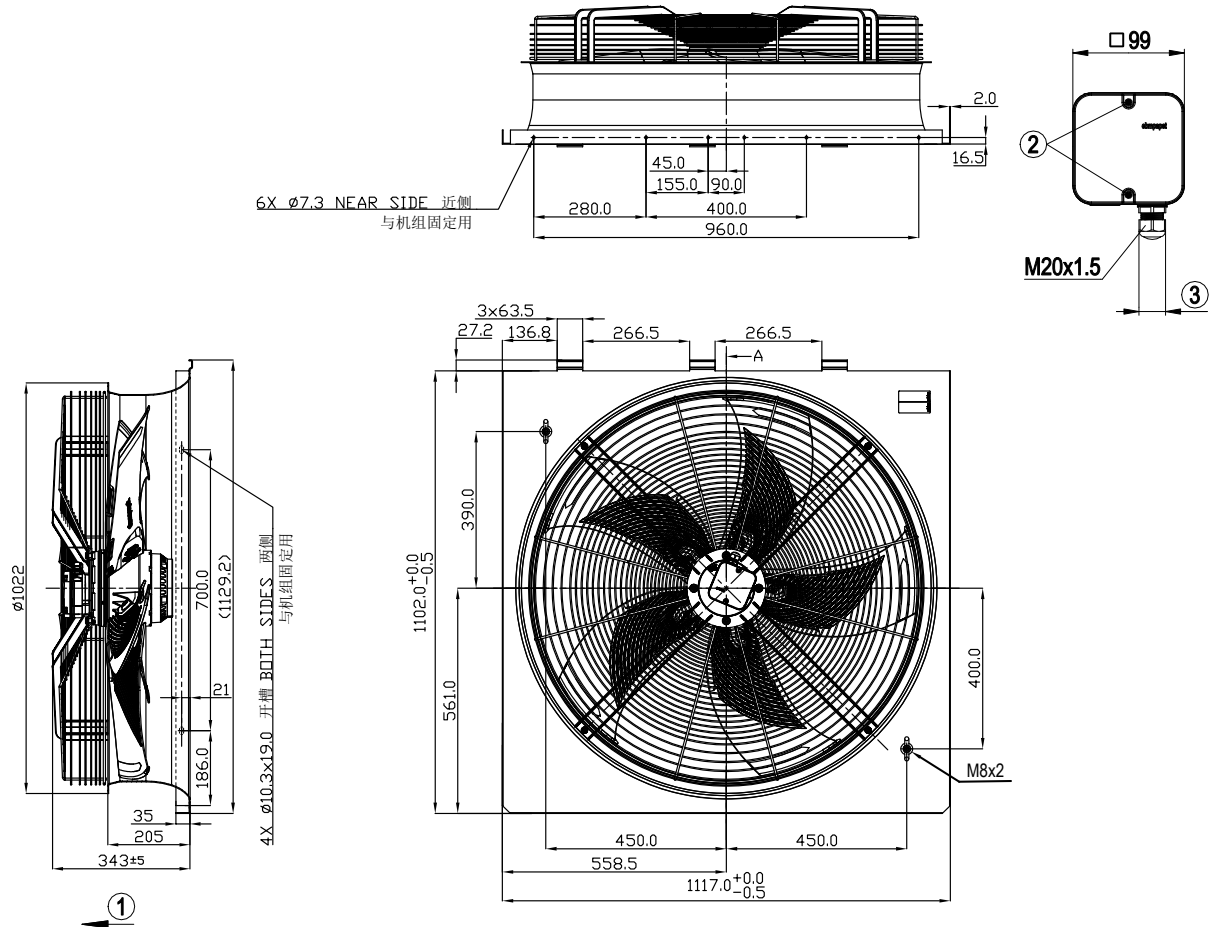

1	Airflow direction "V"
2	Tightening torque 1.5 ± 0.2 Nm
3	Cable diameter min. 7 mm, max. 14 mm, tightening torque 2 ± 0.3 Nm

AC axial fan - AxiBlade

sickle-shaped blades (S series)

with square full nozzle

Connection diagram

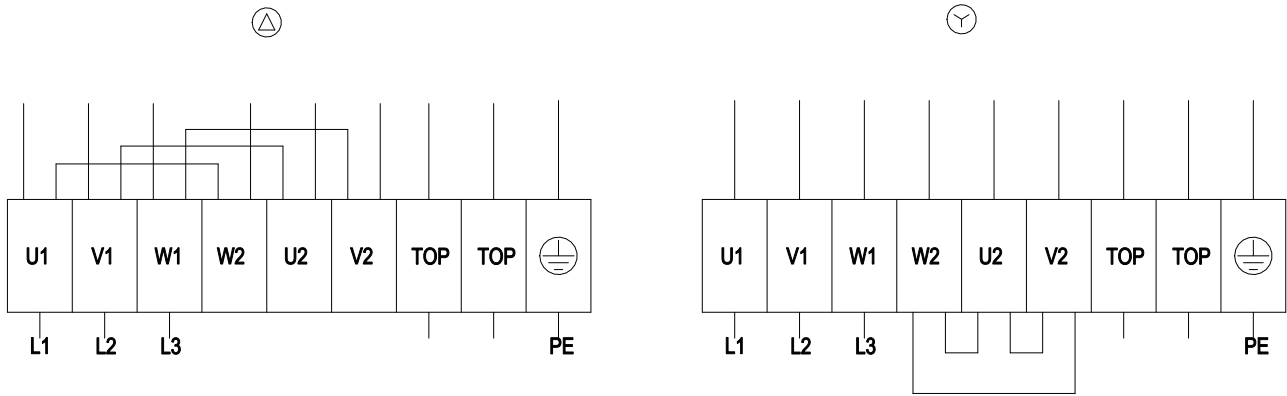

Δ	Delta connection	Y	Star connection	L1	= U1 = black
L2	= V1 = blue	L3	= W1 = brown	W2	yellow
U2	green	V2	white	TOP	2x gray
PE	green/yellow				

AC axial fan - AxiBlade

sickle-shaped blades (S series)

with square full nozzle

Curves: Air performance 50 Hz

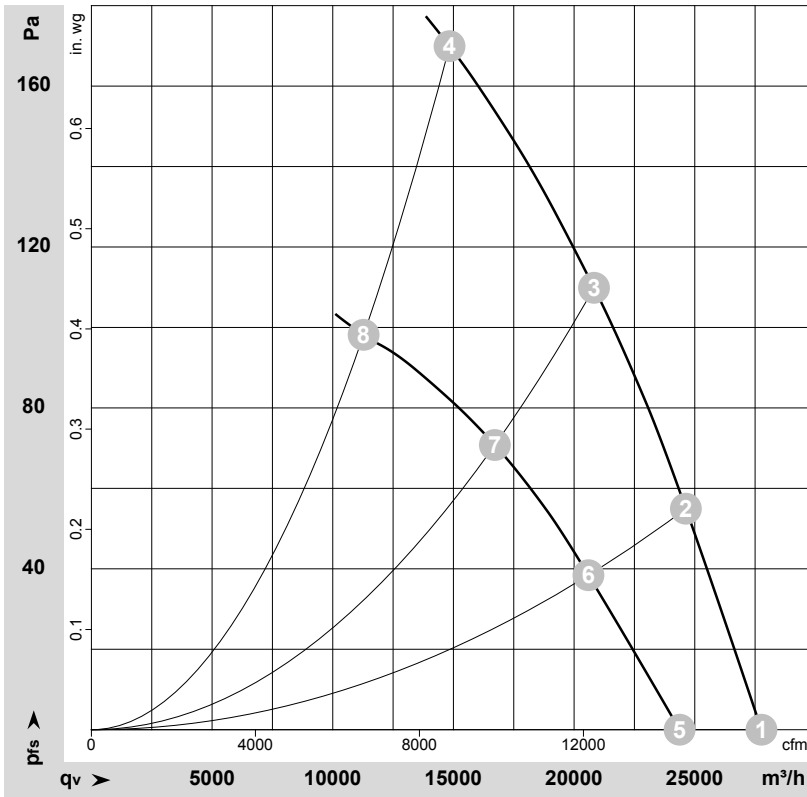

$\rho = 1.15 \text{ kg/m}^3 \pm 2 \%$

Measurement: LU-192850-1
Measurement: LU-193182-1

Air performance measured according to ISO 5801 installation category A. For detailed information on the measurement setup, contact ebm-papst. The values given are valid under the specified measuring conditions and may vary due to conditions of installation. For deviations from the standard configuration, the parameters have to be checked on the installed unit.

Fan performance

	Wired	U	f	n	P _e	I	q _v	P _{fs}	q _v	P _{fs}
		V	Hz	min ⁻¹	W	A	m ³ /h	Pa	cfm	in. wg
1	Δ	400	50	945	1113	2.82	27765	0	16340	0.00
2	Δ	400	50	925	1349	3.09	24635	56	14500	0.22
3	Δ	400	50	910	1572	3.36	20825	110	12255	0.44
4	Δ	400	50	870	1920	3.80	14840	170	8735	0.68
5	Y	400	50	825	836	1.58	24370	0	14345	0.00
6	Y	400	50	775	970	1.84	20595	39	12120	0.16
7	Y	400	50	730	1064	2.03	16715	71	9840	0.29
8	Y	400	50	640	1170	2.20	11280	98	6640	0.39

Wired = Wiring · U = Voltage · f = Frequency · n = Speed (rpm) · P_e = Power consumption · I = Current draw · q_v = Air flow · P_{fs} = Pressure increase

