

W6D910-KA19-03 ebmpapst Datasheet

sales@fansco.com

www.fansco.com

Limited partnership · Headquarters Mulfingen

Amtsgericht (court of registration) Stuttgart · HRA 590344

General partner Elektrobau Mulfingen GmbH · Headquarters Mulfingen

Amtsgericht (court of registration) Stuttgart · HRB 590142

Nominal data

| Type | W6D910-KA19-03 | | | | | | | | |
|-----------------------------|-------------------|----------|----------|----------|------|------|------|------|------|
| Motor | M6D138-NA | | | | | | | | |
| Phase | | 3~ | 3~ | 3~ | 3~ | 3~ | 3~ | 3~ | 3~ |
| Nominal voltage | VAC | 230 | 230 | 277 | 380 | 400 | 400 | 460 | 480 |
| Wiring | | Δ | Δ | Δ | Y | Y | Y | Y | Y |
| Frequency | Hz | 50 | 60 | 60 | 60 | 50 | 60 | 60 | 60 |
| Method of obtaining data | | ml | ml | ml | ml | ml | ml | ml | ml |
| Valid for approval/standard | | CE | CE | CE | CE | CE | CE | CE | CE |
| Speed (rpm) | min ⁻¹ | 910 | 1040 | 1100 | 1020 | 910 | 1040 | 1080 | 1100 |
| Power consumption | W | 1920 | 2370 | 2580 | 2280 | 1920 | 2370 | 2550 | 2580 |
| Current draw | A | 8.2 | 8.5 | 9.0 | 4.8 | 4.7 | 4.8 | 5.0 | 5.1 |
| Max. back pressure | Pa | 180 | 125 | 140 | 120 | 180 | 125 | 135 | 140 |
| Max. back pressure | in. wg | 0.72 | 0.5 | 0.56 | 0.48 | 0.72 | 0.5 | 0.54 | 0.56 |
| Min. ambient temperature | °C | -40 | -40 | -40 | -40 | -40 | -40 | -40 | -40 |
| Max. ambient temperature | °C | 65 | 50 | 50 | 50 | 65 | 50 | 50 | 50 |
| Starting current | A | 31 | 28 | 35 | 15 | 18 | 16 | 19 | 20 |

ml = Max. load · me = Max. efficiency · fa = Free air · cs = Customer specification · ce = Customer equipment
Subject to change

Data according to Commission Regulation (EU) 327/2011 (EN 17166)

| | | Actual | Req. 2015 | | | |
|-----------------------------------|---|--------|-----------|-------------------------------|-------------------|-------|
| 01 Overall efficiency η_{es} | % | 42.7 | 35.2 | 09 Power consumption P_e | kW | 1.76 |
| 02 Measurement category | | A | | 09 Air flow q_v | m ³ /h | 18755 |
| 03 Efficiency category | | Static | | 09 Pressure increase p_{fs} | Pa | 145 |
| 04 Efficiency grade N | | 47.5 | 40 | 10 Speed (rpm) n | min ⁻¹ | 920 |
| 05 Variable speed drive | | No | | 11 Specific ratio* | | 1.00 |

Data obtained at optimum efficiency level.
The ErP data is determined using a motor-impeller combination in a standardized measurement setup.

* Specific ratio = $1 + p_{fs} / 100\,000\text{ Pa}$

LU-195250



AC axial fan - AxiBlade

sickle-shaped blades (S series)

with square full nozzle

Technical description

| | |
|--|--|
| Weight | 54.5 kg |
| Size | 910 mm |
| Motor size | 138 |
| Rotor surface | Painted black |
| Terminal box material | PP plastic |
| Blade material | PP plastic |
| Fan housing material | Sheet steel, galvanized and coated with black plastic (RAL 9005) |
| Guard grille material | Steel, coated with black plastic (RAL 9005) |
| Number of blades | 5 |
| Blade pitch | 0° |
| Airflow direction | V |
| Direction of rotation | Clockwise, viewed toward rotor |
| Degree of protection | IP54 |
| Insulation class | "F" |
| Moisture (F) / Environmental (H) protection class | H2 |
| Ambient temperature note | Occasional start-up at temperatures between -40°C and -25°C is permitted. For continuous operation at ambient temperatures below -25°C (such as refrigeration applications), use must be made of a fan design with special low-temperature bearings. |
| Max. permitted ambient temp. for motor (transport/storage) | +80 °C |
| Min. permitted ambient temp. for motor (transport/storage) | -40 °C |
| Installation position | Any |
| Condensation drainage holes | On rotor and stator sides |
| Mode | S1 |
| Motor bearing | Ball bearing |
| Touch current according to IEC 60990 (measuring circuit Fig. 4, TN system) | <= 3.5 mA |
| Electrical hookup | Terminal box |
| Motor protection | Thermal overload protector (TOP) with basic insulation |
| Protection class | I (with customer connection of protective earth) |
| Conformity with standards | EN 60034-1 (2010); CE |
| Approval | EAC; UL 1004-1; CSA C22.2 No. 100 |



AC axial fan - AxiBlade

sickle-shaped blades (S series)

with square full nozzle

Product drawing

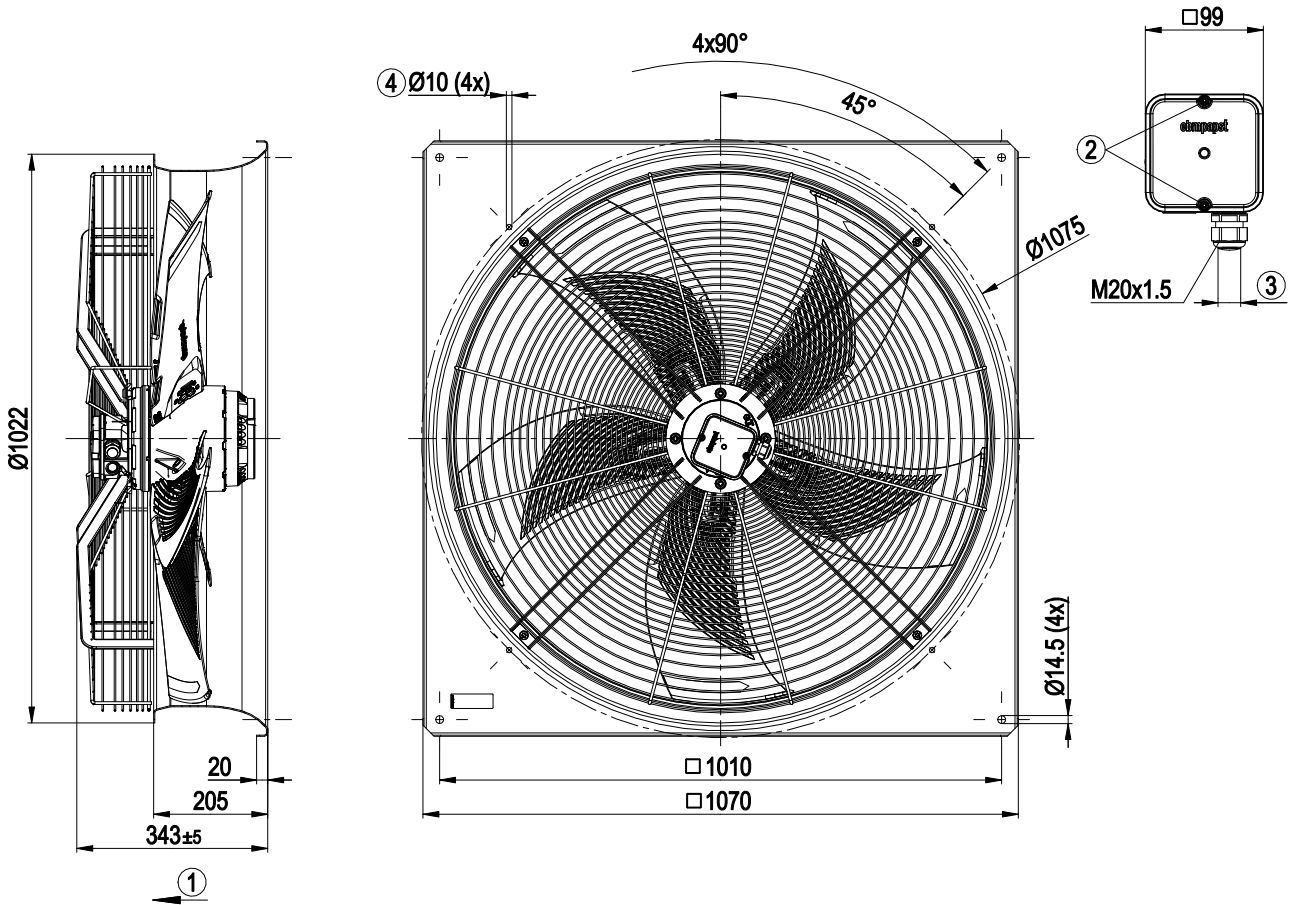

| | |
|---|--|
| 1 | Airflow direction "V" |
| 2 | Tightening torque 1.5 ± 0.2 Nm |
| 3 | Cable diameter min. 7 mm, max. 14 mm, tightening torque 2 ± 0.3 Nm |
| 4 | Mounting holes for FlowGrid |



AC axial fan - AxiBlade

sickle-shaped blades (S series)
with square full nozzle

Connection diagram

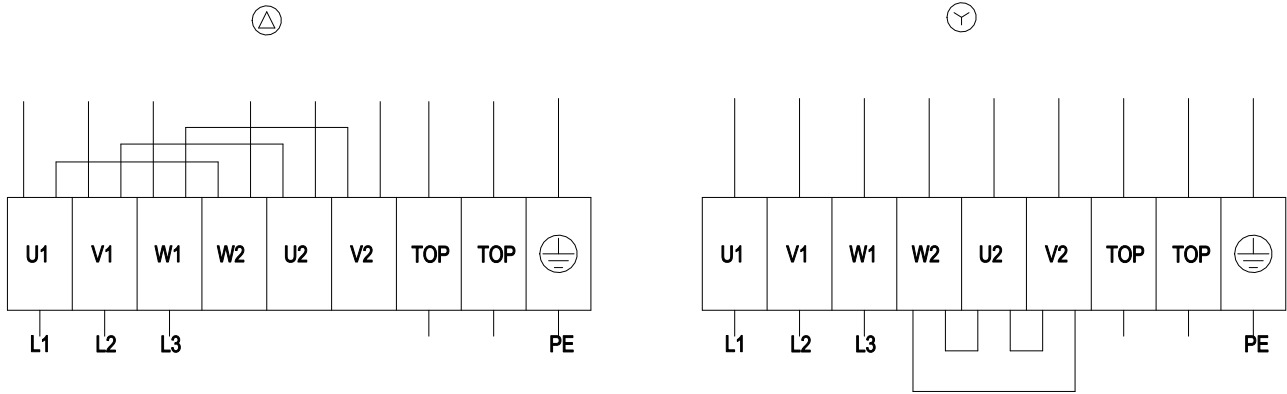

| | | | | | |
|----|------------------|----|-----------------|----|--------------|
| Δ | Delta connection | Y | Star connection | L1 | = U1 = black |
| L2 | = V1 = blue | L3 | = W1 = brown | W2 | yellow |
| U2 | green | V2 | white | PE | green/yellow |



AC axial fan - AxiBlade

sickle-shaped blades (S series)

with square full nozzle

Curves: Air performance 50 Hz

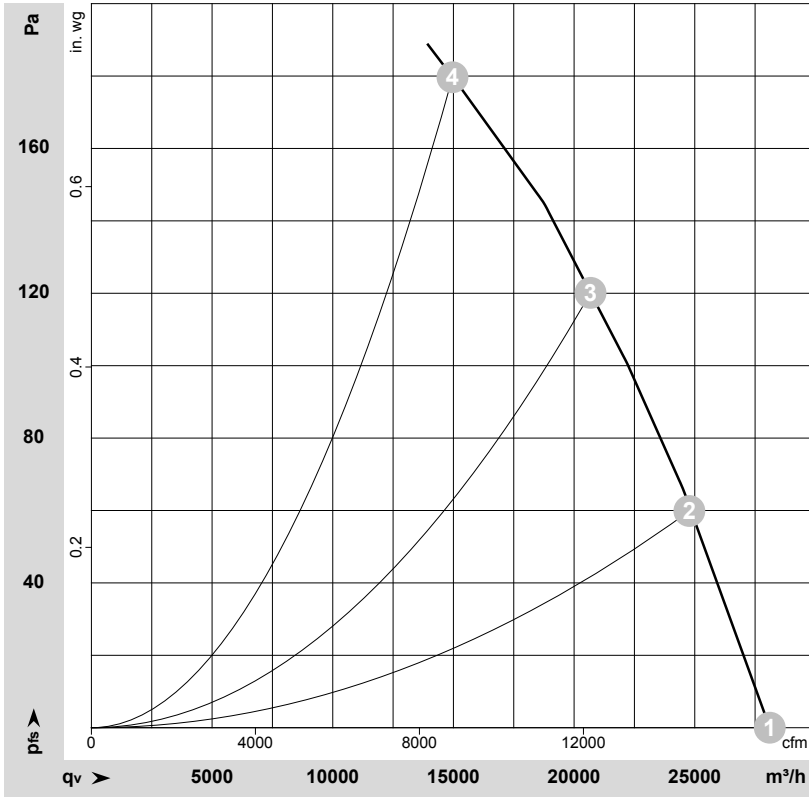

$\rho = 1.15 \text{ kg/m}^3 \pm 2 \%$

Measurement: LU-195250-1

Air performance measured according to ISO 5801 installation category A. For detailed information on the measurement setup, contact ebmpapst. Intake sound level: Sound power level according to ISO 13347 / sound pressure level measured at 1 m distance from fan axis. The values given are valid under the specified measuring conditions and may vary due to conditions of installation. For deviations from the standard configuration, the parameters have to be checked on the installed unit.

Measured values

| | Wired | U | f | n | P _e | I | LpA _{in} | LwA _{in} | LwA _{out} | q _v | p _{fs} | q _v | p _{fs} |
|---|-------|-----|----|-------------------|----------------|------|-------------------|-------------------|--------------------|-------------------|-----------------|----------------|-----------------|
| | | V | Hz | min ⁻¹ | W | A | dB(A) | dB(A) | dB(A) | m ³ /h | Pa | cfm | in. wg |
| 1 | Y | 400 | 50 | 950 | 1164 | 3.83 | 70 | 77 | 77 | 28110 | 0 | 16545 | 0.00 |
| 2 | Y | 400 | 50 | 940 | 1429 | 4.08 | 68 | 75 | 75 | 24775 | 60 | 14585 | 0.24 |
| 3 | Y | 400 | 50 | 925 | 1673 | 4.35 | 70 | 77 | 77 | 20680 | 120 | 12175 | 0.48 |
| 4 | Y | 400 | 50 | 910 | 1920 | 4.70 | 79 | 86 | 87 | 14960 | 180 | 8805 | 0.72 |

Wired = Wiring · U = Voltage · f = Frequency · n = Speed (rpm) · P_e = Power consumption · I = Current draw · LpA_{in} = Sound pressure level intake side · LwA_{in} = Sound power level intake side
 LwA_{out} = Sound power level outlet side · q_v = Air flow · p_{fs} = Pressure increase



AC axial fan - AxiBlade

sickle-shaped blades (S series)

with square full nozzle

Curves: Air performance 60 Hz

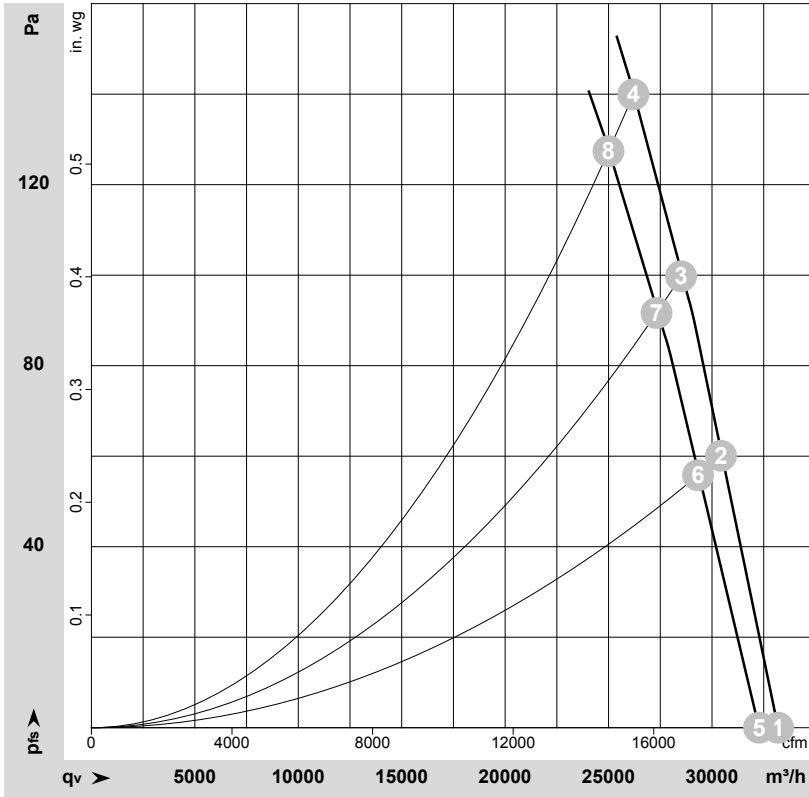

$\rho = 1.15 \text{ kg/m}^3 \pm 2 \%$

Measurement: LU-195146-1
Measurement: LU-196143-1

Air performance measured according to ISO 5801 installation category A. For detailed information on the measurement setup, contact ebm-papst. Intake sound level: Sound power level according to ISO 13347 / sound pressure level measured at 1 m distance from fan axis. The values given are valid under the specified measuring conditions and may vary due to conditions of installation. For deviations from the standard configuration, the parameters have to be checked on the installed unit.

Measured values

| | Wired | U | f | n | P _e | I | LpA _{in} | LwA _{in} | LwA _{out} | q _v | p _{fs} | q _v | p _{fs} |
|---|-------|-----|----|-------------------|----------------|------|-------------------|-------------------|--------------------|-------------------|-----------------|----------------|-----------------|
| | | V | Hz | min ⁻¹ | W | A | dB(A) | dB(A) | dB(A) | m ³ /h | Pa | cfm | in. wg |
| 1 | Y | 480 | 60 | 1135 | 1865 | 4.35 | 74 | 82 | 82 | 33195 | 0 | 19540 | 0.00 |
| 2 | Y | 480 | 60 | 1120 | 2176 | 4.65 | 73 | 80 | 80 | 30435 | 60 | 17915 | 0.24 |
| 3 | Y | 480 | 60 | 1110 | 2379 | 4.86 | 72 | 80 | 80 | 28505 | 100 | 16775 | 0.40 |
| 4 | Y | 480 | 60 | 1100 | 2580 | 5.10 | 73 | 80 | 80 | 26200 | 140 | 15420 | 0.56 |
| 5 | Y | 400 | 60 | 1095 | 1740 | 3.73 | 74 | 81 | 81 | 32270 | 0 | 18995 | 0.00 |
| 6 | Y | 400 | 60 | 1075 | 2015 | 4.15 | 72 | 79 | 79 | 29325 | 57 | 17260 | 0.23 |
| 7 | Y | 400 | 60 | 1060 | 2189 | 4.42 | 71 | 78 | 78 | 27320 | 93 | 16080 | 0.37 |
| 8 | Y | 400 | 60 | 1040 | 2370 | 4.80 | 71 | 78 | 78 | 25000 | 125 | 14715 | 0.50 |

Wired = Wiring · U = Voltage · f = Frequency · n = Speed (rpm) · P_e = Power consumption · I = Current draw · LpA_{in} = Sound pressure level intake side · LwA_{in} = Sound power level intake side
LwA_{out} = Sound power level outlet side · q_v = Air flow · p_{fs} = Pressure increase

