

# AC axial fan - HyBlade

sickle-shaped blades (S series)

with square full nozzle

W6D910-GX09-22 ebmpapst Datasheet

sales@fansco.com

www.fansco.com

Limited partnership · Headquarters Mulfingen

Amtsgericht (court of registration) Stuttgart · HRA 590344

General partner Elektrobau Mulfingen GmbH · Headquarters Mulfingen

Amtsgericht (court of registration) Stuttgart · HRB 590142



## Nominal data

Type	W6D910-GX09-22				
Motor	M6D138-OA				
Phase		3~	3~	3~	3~
Nominal voltage	VAC	400	400	480	480
Wiring		Δ	Y	Δ	Y
Frequency	Hz	50	50	60	60
Method of obtaining data		ml	ml	ml	ml
Valid for approval/standard		CE	CE	CE	CE
Speed (rpm)	min <sup>-1</sup>	925	750	1090	840
Power consumption	W	1950	1410	3000	2020
Current draw	A	4.09	2.59	4.89	3.19
Max. back pressure	Pa	150	105	160	100
Max. back pressure	inH <sub>2</sub> O	0.6	0.42	0.64	0.4
Min. ambient temperature	°C	-40	-40	-40	-40
Max. ambient temperature	°C	75	75	45	45

ml = Max. load · me = Max. efficiency · fa = Free air · cs = Customer specification · ce = Customer equipment

Subject to change

## Data according to ErP Directive

		Actual	Req. 2015			
01 Overall efficiency $\eta_{es}$	%	41.1	35.5	09 Power consumption $P_e$	kW	1.96
02 Measurement category		A		09 Air flow $q_v$	m <sup>3</sup> /h	19140
03 Efficiency category		Static		09 Pressure increase $p_{fs}$	Pa	152
04 Efficiency grade N		45.6	40	10 Speed (rpm) n	min <sup>-1</sup>	925
05 Variable speed drive		No		11 Specific ratio*		1.00

Data obtained at optimum efficiency level.

The ErP data is determined using a motor-impeller combination in a standardized measurement setup.

\* Specific ratio =  $1 + p_g / 100\,000\text{ Pa}$ 

LU-171476



# AC axial fan - HyBlade

sickle-shaped blades (S series)

with square full nozzle

## Technical description

Weight	55.7 kg
Fan size	910 mm
Rotor surface	Cast in aluminum
Terminal box material	PP plastic
Blade material	Sheet aluminum insert, sprayed with PP plastic
Fan housing material	Sheet steel, galvanized and coated with pure white plastic (RAL 9010)
Guard grille material	Steel, coated with black plastic (RAL 9005)
Number of blades	5
Blade pitch	-5°
Airflow direction	"V"
Direction of rotation	Clockwise, viewed toward rotor
Degree of protection	IP54
Insulation class	"F"
Moisture (F) / Environmental (H) protection class	H2
Max. permitted ambient temp. for motor (transport/storage)	+80 °C
Min. permitted ambient temp. for motor (transport/storage)	-40 °C
Installation position	Shaft horizontal or rotor on bottom; rotor on top on request
Condensation drainage holes	On rotor side
Mode	S1
Motor bearing	Ball bearing
Touch current according to IEC 60990 (measuring circuit Fig. 4, TN system)	< 0.75 mA
Electrical hookup	Via terminal box
Motor protection	Thermal overload protector (TOP) with basic insulation
With cable	Axial
Protection class	I (with customer connection of protective earth)
Conformity with standards	EN 60034-1 (2010); EN 61800-5-1; CE
Approval	EAC; UL 1004-1; CSA C22.2 No. 100



# AC axial fan - HyBlade

sickle-shaped blades (S series)

with square full nozzle

## Product drawing

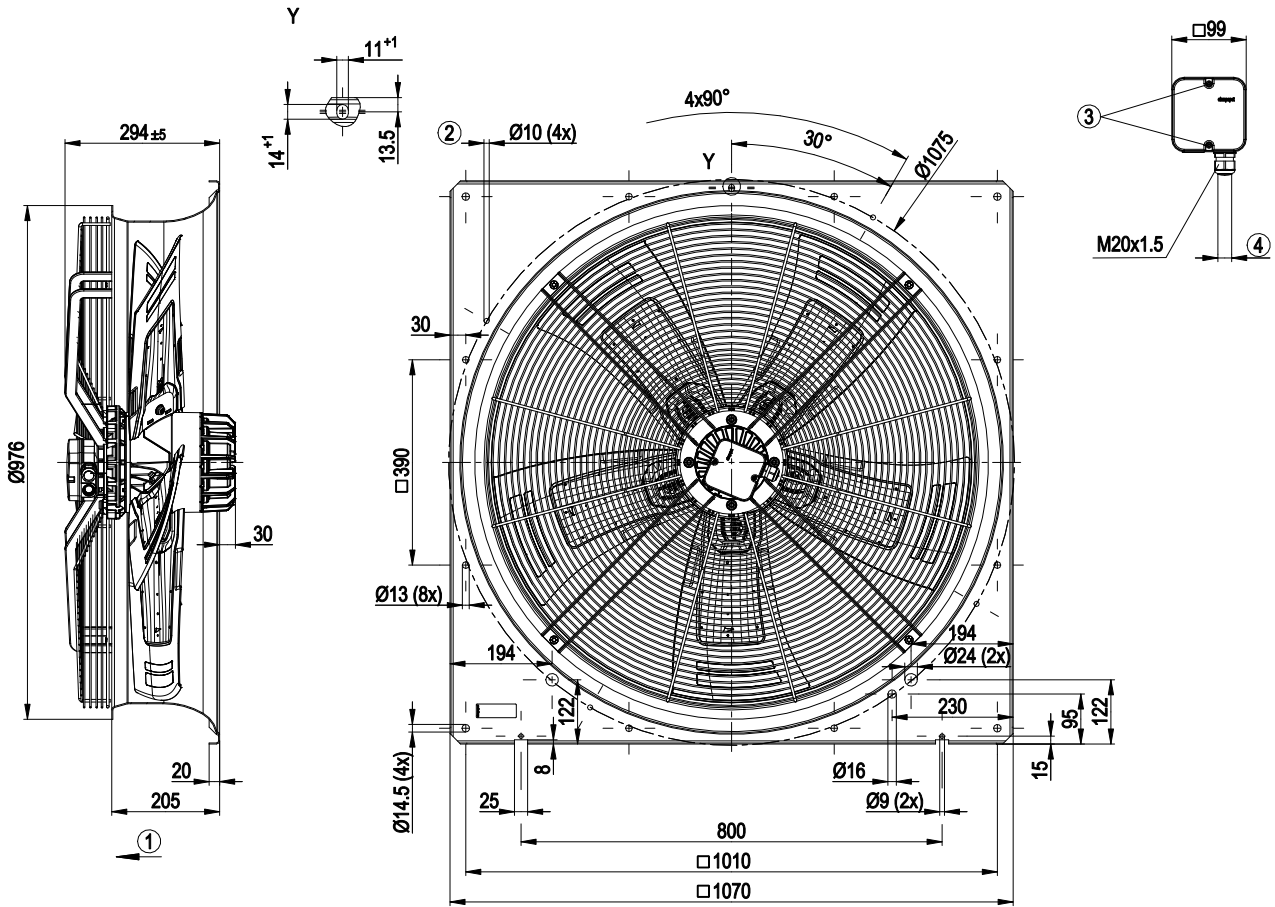

1	Direction of air flow "V"
2	Mounting holes for FlowGrid
3	Tightening torque 1.5 ± 0.2 Nm
4	Cable diameter: min. 7 mm, max. 14 mm; tightening torque 2±0.3 Nm



# AC axial fan - HyBlade

sickle-shaped blades (S series)

with square full nozzle

## Connection diagram



Δ	Delta connection	Y	Star connection	L1	= U1 = black
L2	= V1 = blue	L3	= W1 = brown	W2	yellow
U2	green	V2	white	TOP	2x gray
PE	green/yellow				



# AC axial fan - HyBlade

sickle-shaped blades (S series)

with square full nozzle

## Curves: Air performance 50 Hz

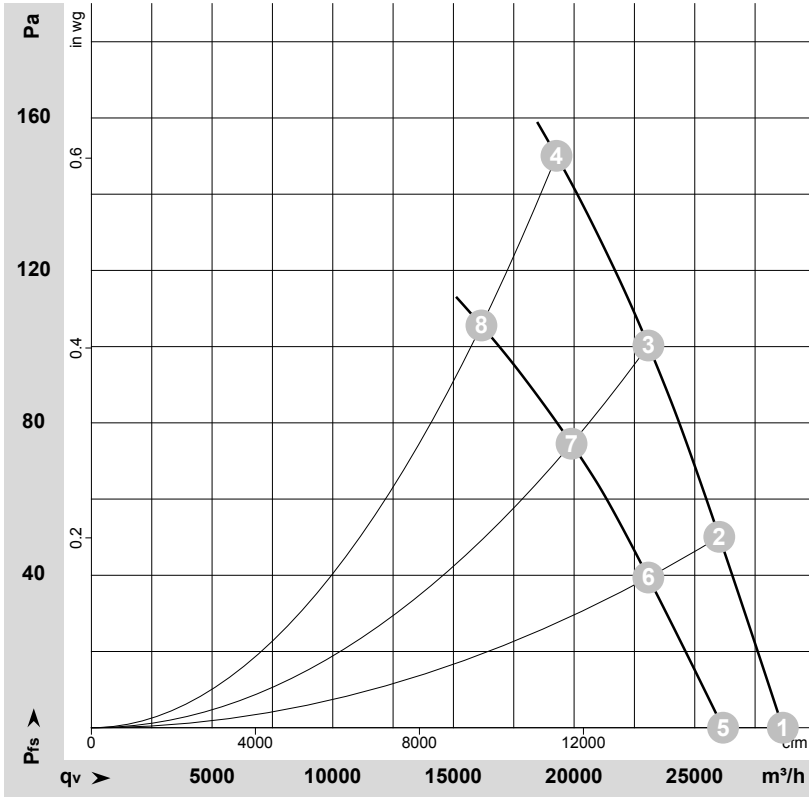

$\rho = 1.15 \text{ kg/m}^3 \pm 2 \%$

Measurement: LU-171476-1  
Measurement: LU-171517-1

Air performance measured according to ISO 5801 installation category A. For detailed information on the measurement setup, contact ebm-papst. Intake sound level: Sound power level according to ISO 13347 / sound pressure level measured at 1 m distance from fan axis. The values given are valid under the specified measuring conditions and may vary due to conditions of installation. For deviations from the standard configuration, the parameters have to be checked on the installed unit.

## Measured values

	Stage	Wired	U	f	n	P <sub>e</sub>	I	LpA <sub>in</sub>	LwA <sub>in</sub>	LwA <sub>out</sub>	qv	P <sub>fs</sub>	qv	P <sub>fs</sub>
			V	Hz	min <sup>-1</sup>	W	A	dB(A)	dB(A)	dB(A)	m <sup>3</sup> /h	Pa	CFM	inH2O
1	1	Δ	400	50	955	1290	3.28	72	79	79	28650	0	16865	0.00
2	1	Δ	400	50	945	1530	3.54	70	77	77	26015	50	15310	0.20
3	1	Δ	400	50	935	1753	3.80	68	75	75	23080	100	13585	0.40
4	1	Δ	400	50	925	1950	4.09	69	76	75	19270	150	11340	0.60
5	1	Y	400	50	860	1036	1.89	69	76	76	26170	0	15405	0.00
6	1	Y	400	50	820	1190	2.16	66	73	73	23075	40	13585	0.16
7	1	Y	400	50	785	1315	2.39	64	71	70	19895	75	11710	0.30
8	1	Y	400	50	750	1410	2.59	64	71	70	16160	105	9510	0.42

Wired = Wiring · U = Power supply · f = Frequency · n = Speed (rpm) · P<sub>e</sub> = Power consumption · I = Current draw · LpA<sub>in</sub> = Sound pressure level intake side · LwA<sub>in</sub> = Sound power level intake side  
LwA<sub>out</sub> = Sound power level outlet side · qv = Air flow · p<sub>fs</sub> = Pressure increase



# AC axial fan - HyBlade

sickle-shaped blades (S series)

with square full nozzle

## Curves: Air performance 60 Hz

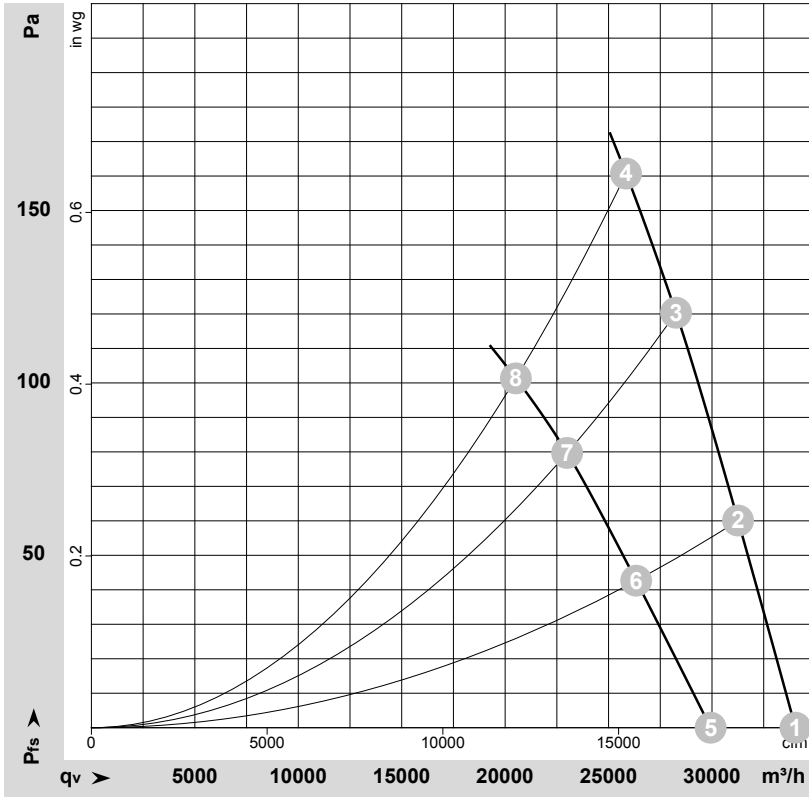

$\rho = 1.15 \text{ kg/m}^3 \pm 2 \%$

Measurement: LU-171513-1  
Measurement: LU-171946-1

Air performance measured according to ISO 5801 installation category A. For detailed information on the measurement setup, contact ebm-papst. Intake sound level: Sound power level according to ISO 13347 / sound pressure level measured at 1 m distance from fan axis. The values given are valid under the specified measuring conditions and may vary due to conditions of installation. For deviations from the standard configuration, the parameters have to be checked on the installed unit.

## Measured values

	Stage	Wired	U	f	n	P <sub>e</sub>	I	LpA <sub>in</sub>	LwA <sub>in</sub>	LwA <sub>out</sub>	qv	P <sub>fs</sub>	qv	P <sub>fs</sub>
			V	Hz	min <sup>-1</sup>	W	A	dB(A)	dB(A)	dB(A)	m <sup>3</sup> /h	Pa	CFM	inH <sub>2</sub> O
1	1	Δ	480	60	1135	2122	3.85	76	84	83	34035	0	20035	0.00
2	1	Δ	480	60	1120	2461	4.23	75	82	82	31260	60	18400	0.24
3	1	Δ	480	60	1105	2785	4.61	73	81	81	28260	120	16635	0.48
4	1	Δ	480	60	1090	3000	4.89	73	80	80	25845	160	15210	0.64
5	1	Y	480	60	970	1643	2.52	72	79	79	29935	0	17620	0.00
6	1	Y	480	60	910	1817	2.82	69	76	76	26335	43	15500	0.17
7	1	Y	480	60	865	1951	3.06	66	74	73	22995	80	13535	0.32
8	1	Y	480	60	840	2020	3.19	66	73	72	20520	100	12075	0.40

Wired = Wiring · U = Power supply · f = Frequency · n = Speed (rpm) · P<sub>e</sub> = Power consumption · I = Current draw · LpA<sub>in</sub> = Sound pressure level intake side · LwA<sub>in</sub> = Sound power level intake side  
LwA<sub>out</sub> = Sound power level outlet side · qv = Air flow · p<sub>fs</sub> = Pressure increase

