

# AC axial fan - HyBlade

sickle-shaped blades (S series)  
with square full nozzle, for barn ventilation

W6D910-DI01-35 ebmpapst Datasheet  
sales@fansco.com  
www.fansco.com

Limited partnership · Headquarters Mulfingen  
Amtsgericht (court of registration) Stuttgart · HRA 590344  
General partner Elektrobau Mulfingen GmbH · Headquarters Mulfingen  
Amtsgericht (court of registration) Stuttgart · HRB 590142

## Nominal data

Type	W6D910-DI01-35		
Motor	M6D138-HF		
Phase		3~	3~
Nominal voltage	VAC	400	400
Wiring		$\Delta$	Y
Frequency	Hz	50	50
Method of obtaining data		ml	ml
Valid for approval/standard		CE	CE
Speed (rpm)	min <sup>-1</sup>	880	650
Power consumption	W	1290	790
Current draw	A	2.65	1.54
Max. back pressure	Pa	140	77
Max. back pressure	in. wg	0.56	0.31
Min. ambient temperature	°C	-25	-25
Max. ambient temperature	°C	65	65
Starting current	A	9	3

ml = Max. load · me = Max. efficiency · fa = Free air · cs = Customer specification · ce = Customer equipment  
Subject to change

## Data according to Commission Regulation (EU) 327/2011

		Actual	Req. 2015		
01 Overall efficiency $\eta_{es}$	%	38.6	34.2	09 Power consumption $P_e$	kW 1.22
02 Measurement category		A		09 Air flow $q_v$	m <sup>3</sup> /h 14545
03 Efficiency category		Static		09 Pressure increase $p_{fs}$	Pa 118
04 Efficiency grade N		44.4	40	10 Speed (rpm) n	min <sup>-1</sup> 885
05 Variable speed drive		No		11 Specific ratio*	1.00

Data obtained at optimum efficiency level.  
The ErP data is determined using a motor-impeller combination in a standardized measurement setup.

\* Specific ratio =  $1 + p_{fs} / 100\,000\text{ Pa}$

LU-120995



# AC axial fan - HyBlade

sickle-shaped blades (S series)  
with square full nozzle, for barn ventilation

## Technical description

Weight	43 kg
Size	910 mm
Motor size	138
Rotor surface	Painted black
Terminal box material	PP plastic
Blade material	Sheet aluminum insert (painted black), sprayed with PP plastic
Support ring material	Steel, coated with black plastic (RAL 9005)
Fan housing material	Sheet steel, galvanized and coated with black plastic (RAL 9005)
Number of blades	5
Blade pitch	-10°
Airflow direction	A
Direction of rotation	Counterclockwise, viewed toward rotor
Degree of protection	IP54
Insulation class	"F"
Moisture (F) / Environmental (H) protection class	H2+A
Ambient temperature note	Occasional start-up at temperatures between -40°C and -25°C is permitted. For continuous operation at ambient temperatures below -25°C (such as refrigeration applications), use must be made of a fan design with special low-temperature bearings.
Max. permitted ambient temp. for motor (transport/storage)	+80 °C
Min. permitted ambient temp. for motor (transport/storage)	-40 °C
Installation position	Shaft horizontal or rotor on top; rotor on bottom on request
Condensation drainage holes	On stator side
Mode	S1
Motor bearing	Ball bearing
Touch current according to IEC 60990 (measuring circuit Fig. 4, TN system)	<= 3.5 mA
Electrical hookup	Terminal box
Motor protection	Thermal overload protector (TOP) with basic insulation
With cable	Axial
Protection class	I (with customer connection of protective earth)
Conformity with standards	EN 60034-1 (2010); CE
Approval	VDE; EAC



# AC axial fan - HyBlade

sickle-shaped blades (S series)  
with square full nozzle, for barn ventilation

## Product drawing

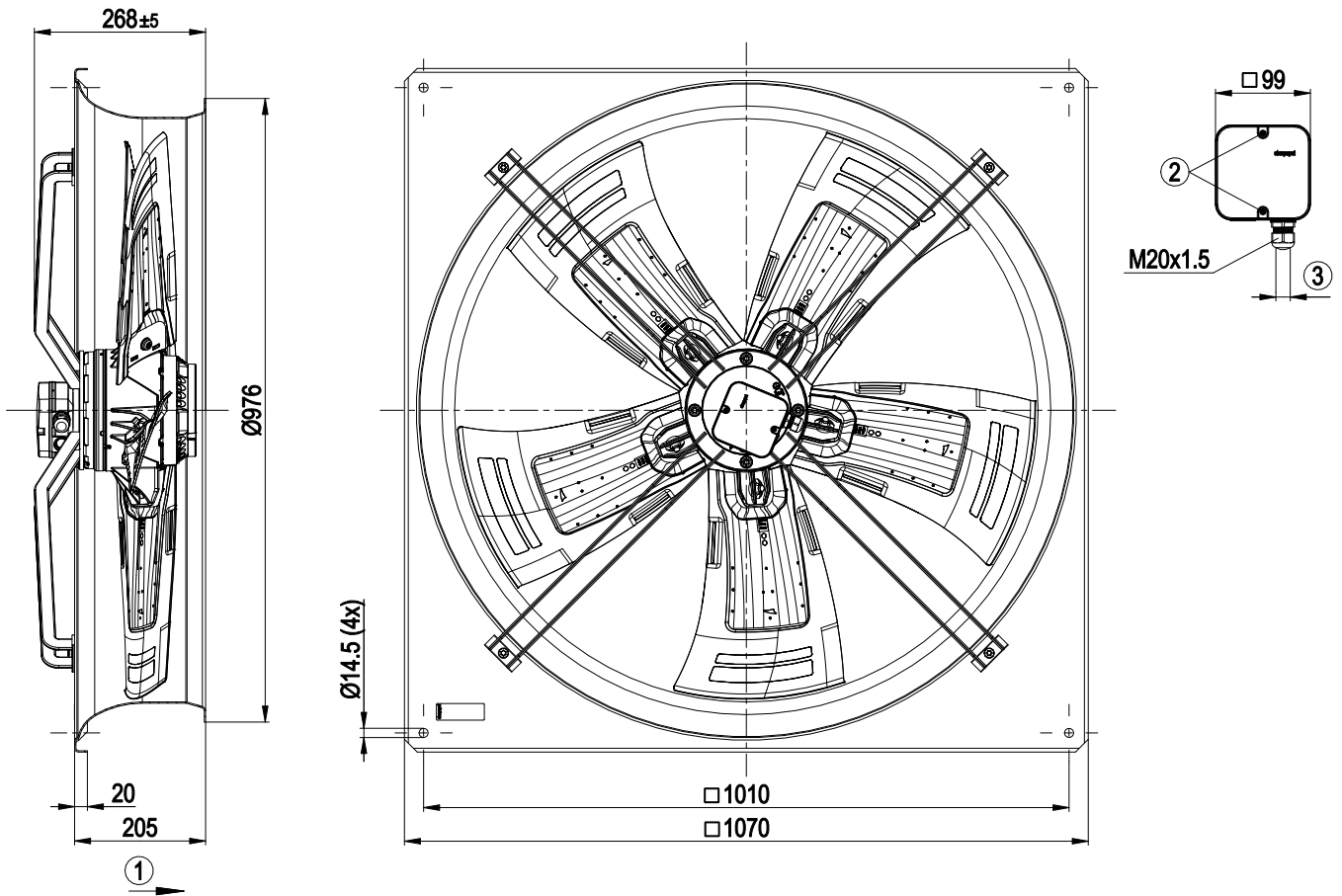

1	Direction of air flow "A"
2	Tightening torque $1.5 \pm 0.2$ Nm
3	Cable diameter min. 7 mm, max. 14 mm, tightening torque $2 \pm 0.3$ Nm



# AC axial fan - HyBlade

sickle-shaped blades (S series)  
with square full nozzle, for barn ventilation

## Connection diagram

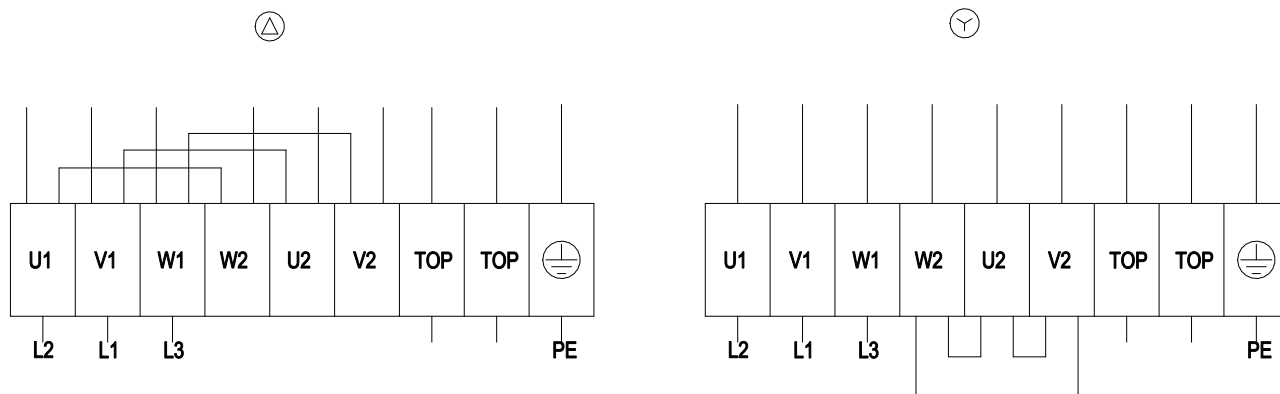

Δ	Delta connection	Y	Star connection	L1	= V1 = blue
L2	= U1 = black	L3	= W1 = brown	W2	yellow
U2	green	V2	white	TOP	2x gray
PE	green/yellow				



# AC axial fan - HyBlade

sickle-shaped blades (S series)  
with square full nozzle, for barn ventilation

## Curves: Air performance 50 Hz

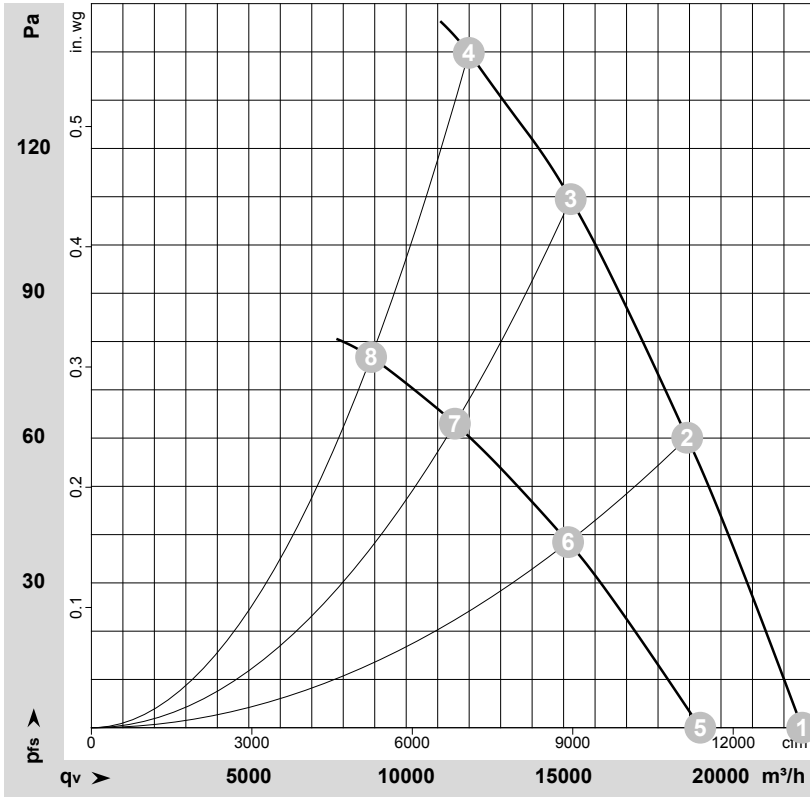

$\rho = 1.15 \text{ kg/m}^3 \pm 2 \%$

Measurement: LU-120995-1  
Measurement: LU-121001-1

Air performance measured according to ISO 5801 installation category A. For detailed information on the measurement setup, contact ebmpapst. Intake sound level: Sound power level according to ISO 13347 / sound pressure level measured at 1 m distance from fan axis. The values given are valid under the specified measuring conditions and may vary due to conditions of installation. For deviations from the standard configuration, the parameters have to be checked on the installed unit.

## Measured values

	Wired	U	f	n	P <sub>e</sub>	I	LpA <sub>in</sub>	LwA <sub>in</sub>	LwA <sub>out</sub>	q <sub>v</sub>	p <sub>fs</sub>	q <sub>v</sub>	p <sub>fs</sub>
		V	Hz	min <sup>-1</sup>	W	A	dB(A)	dB(A)	dB(A)	m <sup>3</sup> /h	Pa	cfm	in. wg
1	Δ	400	50	935	785	2.07	72	79	79	22580	0	13290	0.00
2	Δ	400	50	910	1034	2.34	69	77	76	18925	60	11140	0.24
3	Δ	400	50	890	1205	2.55	71	78	78	15225	110	8960	0.44
4	Δ	400	50	880	1290	2.65	80	87	88	11990	140	7055	0.56
5	Y	400	50	800	589	1.12	68	75	75	19340	0	11385	0.00
6	Y	400	50	730	703	1.35	64	71	70	15145	38	8915	0.15
7	Y	400	50	675	765	1.49	65	72	72	11550	63	6795	0.25
8	Y	400	50	650	790	1.54	71	78	79	8885	77	5230	0.31

Wired = Wiring · U = Voltage · f = Frequency · n = Speed (rpm) · P<sub>e</sub> = Power consumption · I = Current draw · LpA<sub>in</sub> = Sound pressure level intake side · LwA<sub>in</sub> = Sound power level intake side  
LwA<sub>out</sub> = Sound power level outlet side · q<sub>v</sub> = Air flow · p<sub>fs</sub> = Pressure increase

