

# AC axial fan - HyBlade

sickle-shaped blades (S series)

Fan housing with guard grille

W6D910-DA01-02 ebmpapst Datasheet FansCo

sales@fansco.com

www.fansco.com

## Nominal data

Type	W6D910-DA01-02		
Motor	M6D138-NA		
Phase		3~	3~
Nominal voltage	VAC	400	400
Wiring		$\Delta$	Y
Frequency	Hz	50	50
Method of obtaining data		ml	ml
Valid for approval/standard		CE	CE
Speed	min <sup>-1</sup>	885	685
Power consumption	W	2480	1570
Current draw	A	5.15	2.9
Max. back pressure	Pa	150	90
Min. ambient temperature	°C	-40	-40
Max. ambient temperature	°C	50	50
Starting current	A	18.6	6.2

ml = Max. load · me = Max. efficiency · fa = Free air · cs = Customer specification · ce = Customer equipment  
Subject to change

## Data according to ErP Directive

		Actual	Req. 2015			
01 Overall efficiency $\eta_{es}$	%	36.1	36.1	09 Power consumption $P_e$	kW	2.46
02 Measurement category		A		09 Air flow $q_v$	m <sup>3</sup> /h	21770
03 Efficiency category		Static		09 Pressure increase $p_{fs}$	Pa	142
04 Efficiency grade N		40	40	10 Speed n	min <sup>-1</sup>	890
05 Variable speed drive		No		11 Specific ratio*		1.00

Data obtained at optimum efficiency level.  
The ErP data is determined using a motor-impeller combination in a standardized measurement setup.

\* Specific ratio =  $1 + p_g / 100\,000\text{ Pa}$ 

LU-136151



# AC axial fan - HyBlade

sickle-shaped blades (S series)

Fan housing with guard grille

## Technical description

Weight	52.4 kg
Fan size	910 mm
Rotor surface	Cast in aluminum
Terminal box material	PP plastic
Blade material	Sheet aluminum insert (painted black), sprayed with PP plastic
Fan housing material	Sheet steel, galvanized and coated with black plastic (RAL 9005)
Guard grille material	Steel, coated with black plastic (RAL 9005)
Number of blades	5
Blade pitch	0°
Airflow direction	"A"
Direction of rotation	Counterclockwise, viewed toward rotor
Degree of protection	IP54
Insulation class	"F"
Moisture (F) / Environmental (H) protection class	F3-1
Max. permitted ambient temp. for motor (transport/storage)	+80 °C
Min. permitted ambient temp. for motor (transport/storage)	-40 °C
Installation position	Any
Condensation drainage holes	On rotor and stator sides
Mode	S1
Motor bearing	Ball bearing
Touch current according to IEC 60990 (measuring circuit Fig. 4, TN system)	<= 3.5 mA
Electrical hookup	Via terminal box
Motor protection	Thermal overload protector (TOP) with basic insulation
With cable	Axial
Protection class	I (with customer connection of protective earth)
Conformity with standards	EN 60034-1 (2010); EN 61800-5-1; CE
Approval	EAC; VDE



# AC axial fan - HyBlade

sickle-shaped blades (S series)

Fan housing with guard grille

## Product drawing

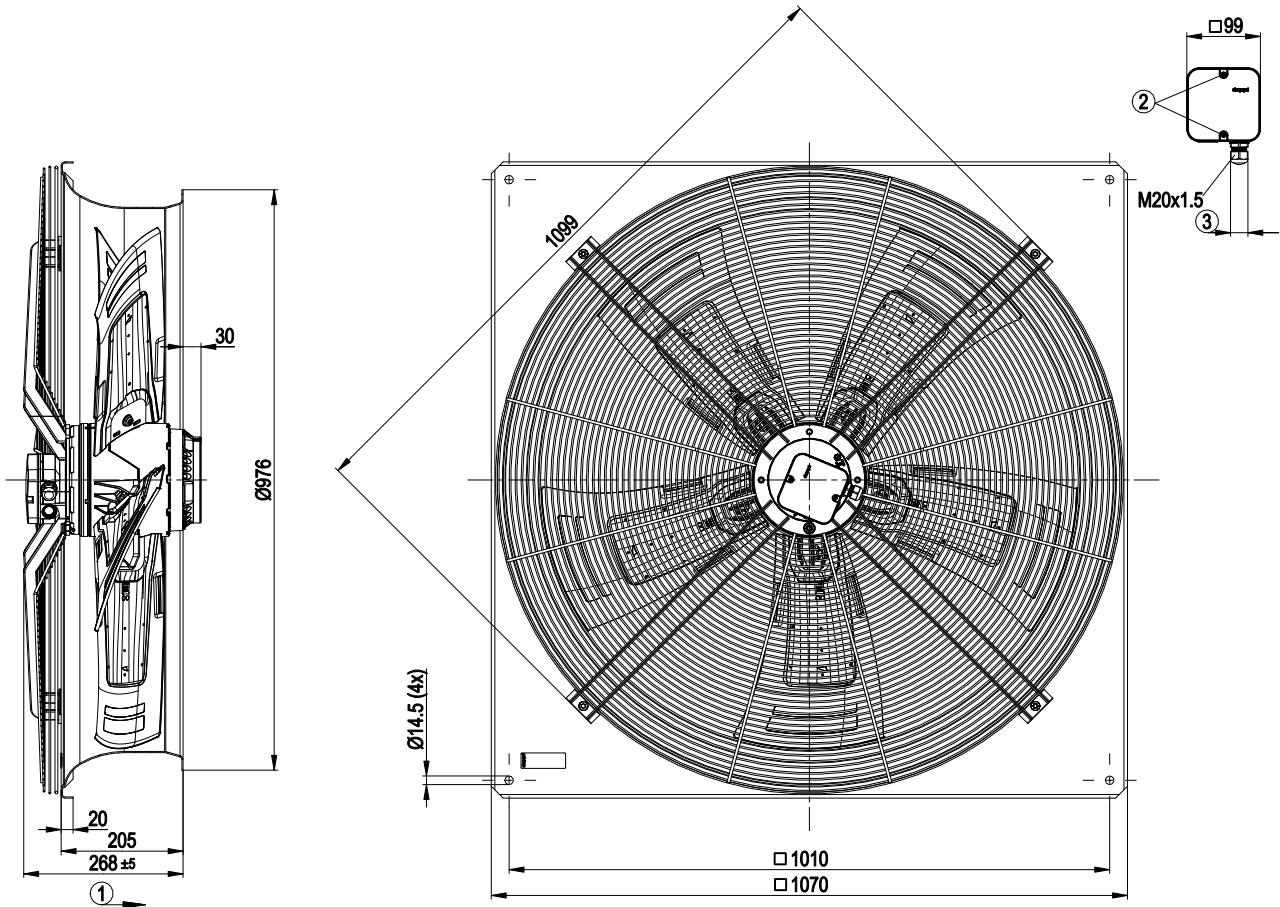

1	Direction of air flow "A"
2	Tightening torque 1.5 ± 0.2 Nm
3	Cable diameter min. 7 mm, max. 14 mm; tightening torque 2 ± 0.3 Nm



# AC axial fan - HyBlade

sickle-shaped blades (S series)

Fan housing with guard grille

## Connection diagram

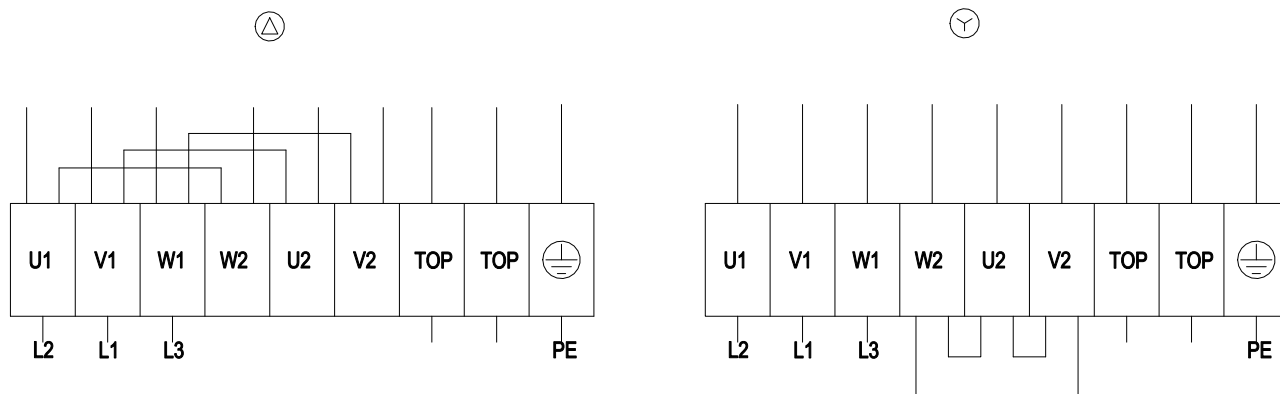

Δ	Delta connection	Y	Star connection	L1	= V1 = blue
L2	= U1 = black	L3	= W1 = brown	W2	yellow
U2	green	V2	white	TOP	2x gray
PE	green/yellow				

# AC axial fan - HyBlade

sickle-shaped blades (S series)

Fan housing with guard grille

## Curves: Air performance 50 Hz

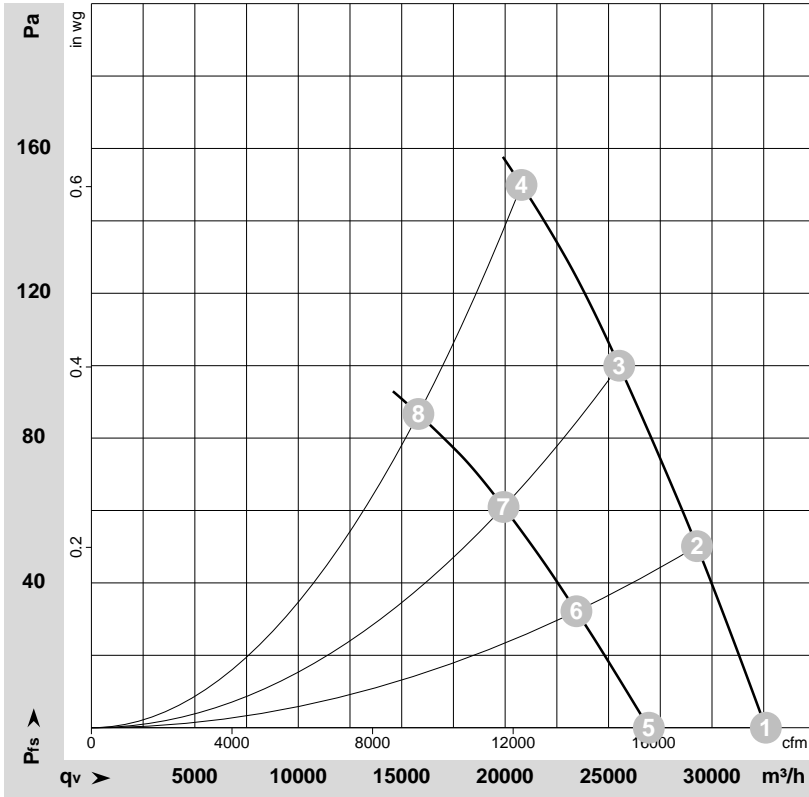

$\rho = 1.15 \text{ kg/m}^3 \pm 2 \%$

Measurement: LU-136151-1  
Measurement: LU-118398-1

Air performance measured according to ISO 5801 installation category A. For detailed information on the measurement setup, contact ebm-papst. Intake sound level: Sound power level according to ISO 13347 / sound pressure level measured at 1 m distance from fan axis. The values given are valid under the specified measuring conditions and may vary due to conditions of installation. For deviations from the standard configuration, the parameters have to be checked on the installed unit.

## Measured values

	Wired	U	f	n	P <sub>e</sub>	I	LpA <sub>in</sub>	LwA <sub>in</sub>	LwA <sub>out</sub>	qv	p <sub>fs</sub>
		V	Hz	min <sup>-1</sup>	W	A	dB(A)	dB(A)	dB(A)	m <sup>3</sup> /h	Pa
1	Δ	400	50	925	1848	4.31	70	78	78	32605	0
2	Δ	400	50	910	2084	4.59	69	76	77	29275	50
3	Δ	400	50	900	2298	4.86	68	76	76	25515	100
4	Δ	400	50	885	2480	5.15	70	77	77	20790	150
5	Y	400	50	785	1290	2.44	65	73	73	26945	0
6	Y	400	50	745	1412	2.67	63	70	70	23445	32
7	Y	400	50	715	1491	2.82	61	69	69	19925	61
8	Y	400	50	685	1570	2.90	63	71	70	15805	87

Wired = Wiring · U = Power supply · f = Frequency · n = Speed · P<sub>e</sub> = Power consumption · I = Current draw · LpA<sub>in</sub> = Sound pressure level intake side · LwA<sub>in</sub> = Sound power level intake side  
LwA<sub>out</sub> = Sound power level outlet side · qv = Air flow · p<sub>fs</sub> = Pressure increase

