

# AC axial fan - HyBlade

sickle-shaped blades (S series)

with round full nozzle, Transformer fan

W6D910-CB05-80 ebmpapst Datasheet

sales@fansco.com

www.fansco.com

Limited partnership · Headquarters Mulfingen

Amtsgericht (court of registration) Stuttgart · HRA 590344

General partner Elektrobau Mulfingen GmbH · Headquarters Mulfingen

Amtsgericht (court of registration) Stuttgart · HRB 590142

## Nominal data

Type	W6D910-CB05-80				
Motor	M6D138-NA				
Phase		3~	3~	3~	3~
Nominal voltage	VAC	230	277	400	480
Wiring		$\Delta$	$\Delta$	Y	Y
Frequency	Hz	50	60	50	60
Method of obtaining data		fa	fa	fa	fa
Valid for approval/standard		CE	CE	CE	CE
Speed (rpm)	min <sup>-1</sup>	950	1120	950	1120
Power consumption	W	1510	2440	1510	2440
Current draw	A	7.3	8.1	4.2	4.7
Max. back pressure	Pa	160	140	160	140
Max. back pressure	in. wg	0.64	0.56	0.64	0.56
Min. ambient temperature	°C	-40	-40	-40	-40
Max. ambient temperature	°C	70	45	70	45
Starting current	A	33	37	19	21.5

ml = Max. load · me = Max. efficiency · fa = Free air · cs = Customer specification · ce = Customer equipment  
Subject to change

## Data according to Commission Regulation (EU) 327/2011 (EN 17166)

		Actual	Req. 2015			
01 Overall efficiency $\eta_{es}$	%	36.6	35.6	09 Power consumption $P_e$	kW	2.04
02 Measurement category		A		09 Air flow $q_v$	m <sup>3</sup> /h	16695
03 Efficiency category		Static		09 Pressure increase $p_{fs}$	Pa	162
04 Efficiency grade N		41	40	10 Speed (rpm) n	min <sup>-1</sup>	920
05 Variable speed drive		No		11 Specific ratio*		1.00

Data obtained at optimum efficiency level.  
The ErP data is determined using a motor-impeller combination in a standardized measurement setup.

\* Specific ratio =  $1 + p_s / 100\,000\text{ Pa}$

LU-157134



# AC axial fan - HyBlade

sickle-shaped blades (S series)

with round full nozzle, Transformer fan

## Technical description

Weight	54.1 kg
Size	910 mm
Motor size	138
Rotor surface	Painted black
Terminal box material	Die-cast aluminum, painted black
Blade material	Sheet aluminum insert (painted black), sprayed with PP plastic
Fan housing material	Sheet steel, galvanized and coated with white aluminum plastic (RAL 9006)
Guard grille material	Steel, coated with white-aluminum plastic (RAL 9006)
Number of blades	5
Blade pitch	-5°
Airflow direction	A
Direction of rotation	Counterclockwise, viewed toward rotor
Degree of protection	IP55
Insulation class	"F"
Moisture (F) / Environmental (H) protection class	H2+T
Ambient temperature note	Occasional start-up at temperatures between -40°C and -25°C is permitted. For continuous operation at ambient temperatures below -25°C (such as refrigeration applications), use must be made of a fan design with special low-temperature bearings.
Max. permitted ambient temp. for motor (transport/storage)	+ 80 °C
Min. permitted ambient temp. for motor (transport/storage)	- 40 °C
Installation position	Shaft horizontal or rotor on top; rotor on bottom on request
Condensation drainage holes	On stator side
Mode	S1
Motor bearing	Ball bearing
Touch current according to IEC 60990 (measuring circuit Fig. 4, TN system)	≤ 3.5 mA
Electrical hookup	Terminal box
Motor protection	Thermal overload protector (TOP) with basic insulation
With cable	Axial
Protection class	I (with customer connection of protective earth)
Conformity with standards	EN 60034-1 (2010); CE
Approval	CSA C22.2 No. 100; EAC; UL 1004-1



# AC axial fan - HyBlade

sickle-shaped blades (S series)

with round full nozzle, Transformer fan

## Product drawing

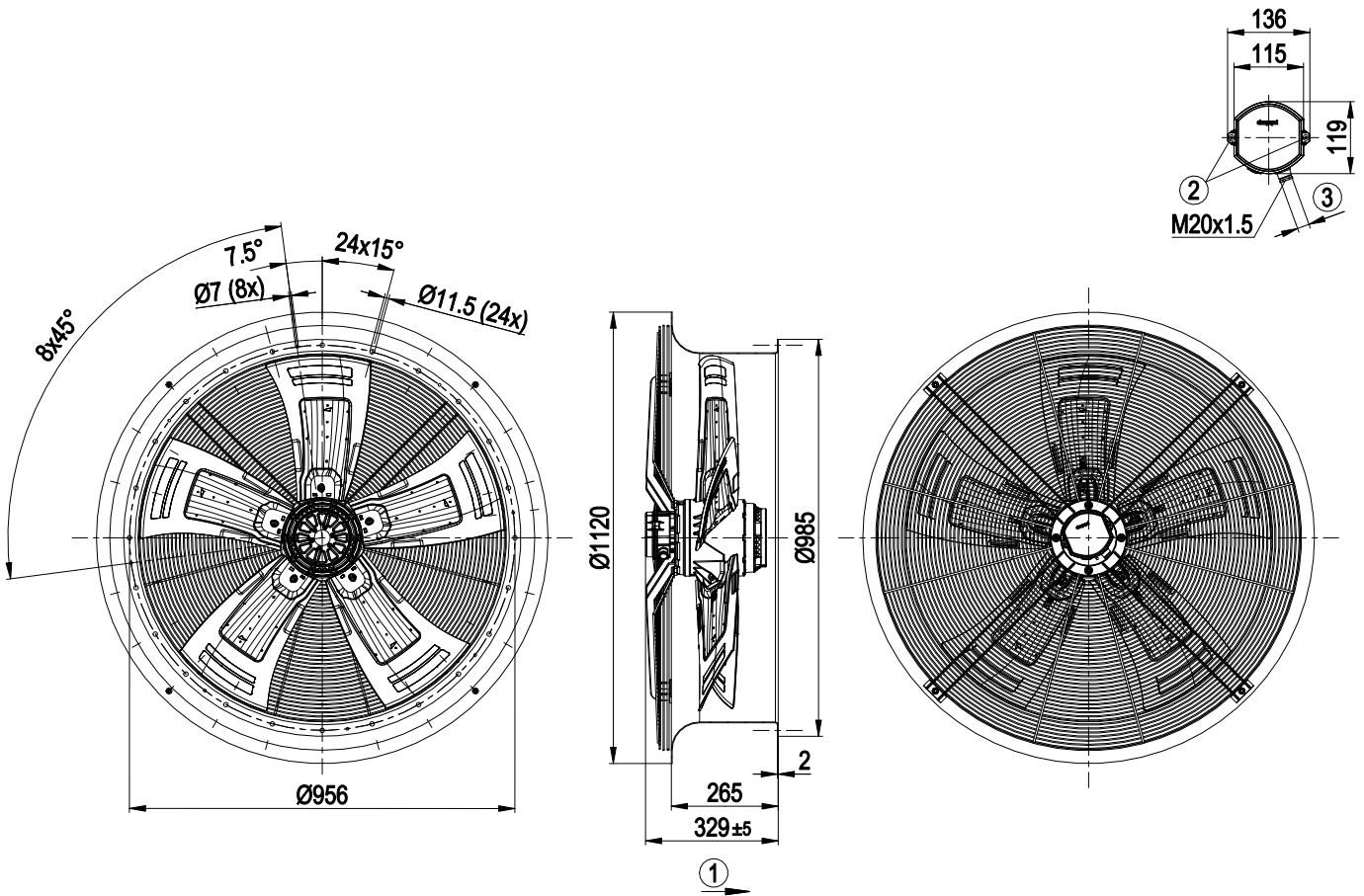

1	Direction of air flow "A"
2	Tightening torque $2.5 \pm 0.4$ Nm
3	Cable diameter min. 10 mm, max. 12 mm, tightening torque $4 \pm 0.6$ Nm



# AC axial fan - HyBlade

sickle-shaped blades (S series)  
with round full nozzle, Transformer fan

## Connection diagram

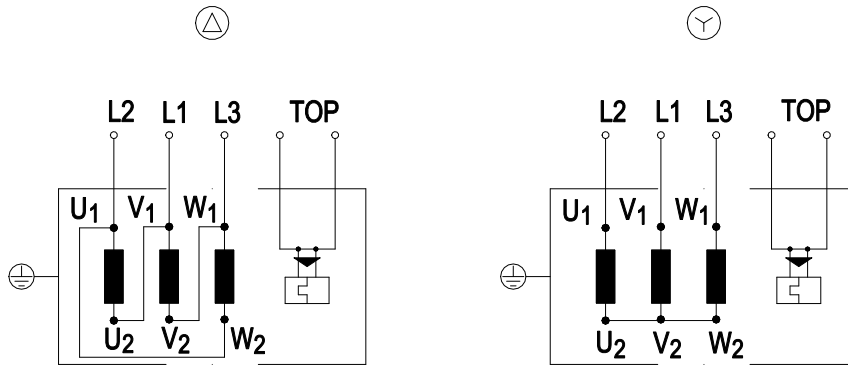

Change of rotation direction by reversing two phases

Δ	Delta connection	Y	Star connection	L2	= U1 = black
L1	= V1 = blue	L3	= W1 = brown	W2	yellow
U2	green	V2	white	TOP	2x gray
PE	green/yellow				



# AC axial fan - HyBlade

sickle-shaped blades (S series)

with round full nozzle, Transformer fan

## Curves: Air performance 50 Hz

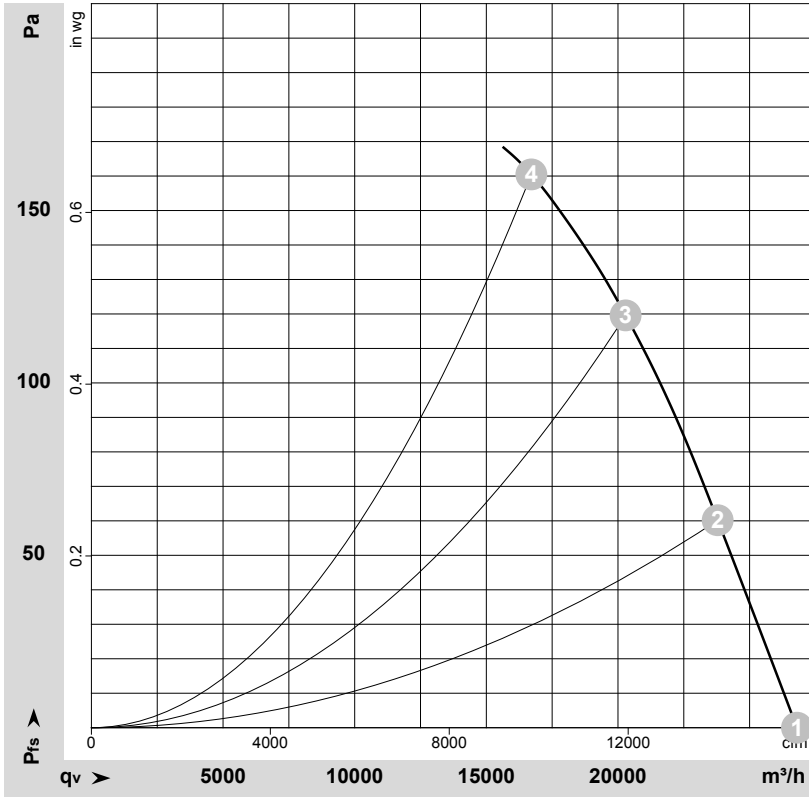

$\rho = 1.15 \text{ kg/m}^3 \pm 2 \%$

Measurement: LU-157134-1

Air performance measured according to ISO 5801 installation category A. For detailed information on the measurement setup, contact ebmpapst. Intake sound level: Sound power level according to ISO 13347 / sound pressure level measured at 1 m distance from fan axis. The values given are valid under the specified measuring conditions and may vary due to conditions of installation. For deviations from the standard configuration, the parameters have to be checked on the installed unit.

## Measured values

	Wired	U	f	n	$P_e$	I	$LpA_{in}$	$LwA_{in}$	$LwA_{out}$	$q_v$	$p_{fs}$	$q_v$	$p_{fs}$
		V	Hz	$\text{min}^{-1}$	W	A	dB(A)	dB(A)	dB(A)	$\text{m}^3/\text{h}$	Pa	cfm	in. wg
1	Y	400	50	950	1510	4.20	77	83	83	26800	0	15775	0.00
2	Y	400	50	935	1748	4.36	75	82	82	23785	60	14000	0.24
3	Y	400	50	925	1937	4.55	74	80	80	20290	120	11945	0.48
4	Y	400	50	920	2045	4.65	81	86	87	16710	160	9835	0.64

Wired = Wiring · U = Voltage · f = Frequency · n = Speed (rpm) ·  $P_e$  = Power consumption · I = Current draw ·  $LpA_{in}$  = Sound pressure level intake side ·  $LwA_{in}$  = Sound power level intake side  
 $LwA_{out}$  = Sound power level outlet side ·  $q_v$  = Air flow ·  $p_{fs}$  = Pressure increase



# AC axial fan - HyBlade

sickle-shaped blades (S series)  
with round full nozzle, Transformer fan

## Curves: Air performance 60 Hz

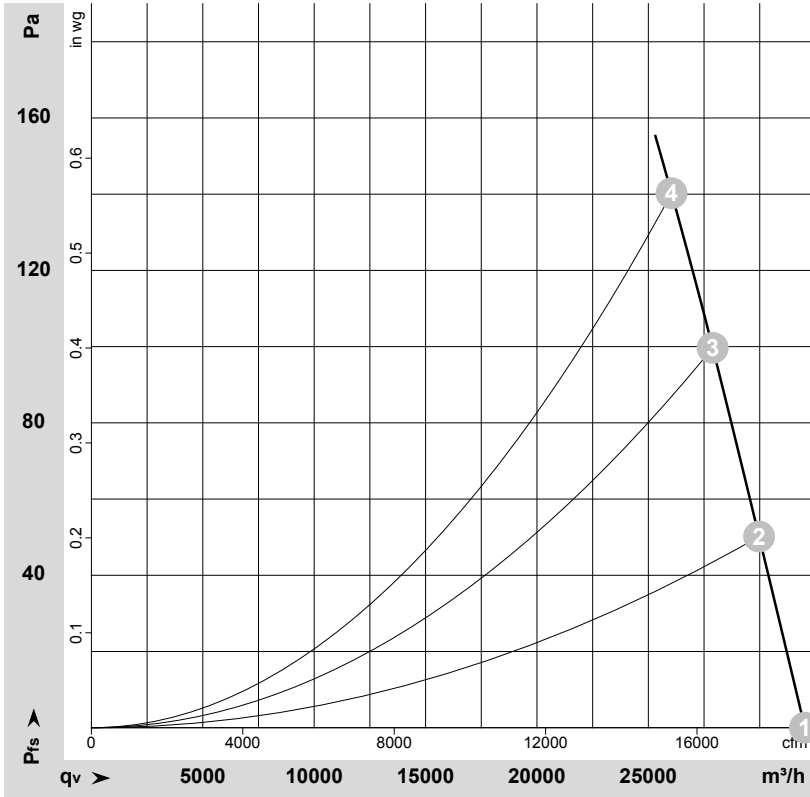

$\rho = 1.182 \text{ kg/m}^3 \pm 2 \%$

Measurement: LU-170000-1

Air performance measured according to ISO 5801 installation category A. For detailed information on the measurement setup, contact ebmpapst. Intake sound level: Sound power level according to ISO 13347 / sound pressure level measured at 1 m distance from fan axis. The values given are valid under the specified measuring conditions and may vary due to conditions of installation. For deviations from the standard configuration, the parameters have to be checked on the installed unit.

## Measured values

	Wired	U	f	n	P <sub>e</sub>	I	LpA <sub>in</sub>	LwA <sub>in</sub>	LwA <sub>out</sub>	q <sub>v</sub>	p <sub>fs</sub>	q <sub>v</sub>	p <sub>fs</sub>
		V	Hz	min <sup>-1</sup>	W	A	dB(A)	dB(A)	dB(A)	m <sup>3</sup> /h	Pa	cfm	in. wg
1	Y	480	60	1120	2440	4.70	80	87	88	32025	0	18850	0.00
2	Y	480	60	1110	2673	4.88	79	87	87	29970	50	17640	0.20
3	Y	480	60	1100	2901	5.13	78	86	86	27890	100	16415	0.40
4	Y	480	60	1090	3078	5.33	78	85	85	26040	140	15325	0.56

Wired = Wiring · U = Voltage · f = Frequency · n = Speed (rpm) · P<sub>e</sub> = Power consumption · I = Current draw · LpA<sub>in</sub> = Sound pressure level intake side · LwA<sub>in</sub> = Sound power level intake side  
LwA<sub>out</sub> = Sound power level outlet side · q<sub>v</sub> = Air flow · p<sub>fs</sub> = Pressure increase

