

W6D800-NG13-01 ebmpapst Datasheet
 sales@fansco.com
 www.fansco.com

Limited partnership · Headquarters Muldingen
 County court Stuttgart · HRA 590344

General partner Elektrobau Muldingen GmbH · Headquarters Muldingen
 County court Stuttgart · HRB 590142

Nominal data

Type	W6D800-NG13-01	
Motor	M6D138-HF	
Phase		3~
Nominal voltage	VAC	400
Connection		Δ
Frequency	Hz	50
Type of data definition		ml
Valid for approval / standard		CE
Speed (rpm)	min ⁻¹	880
Power input	W	1340
Current draw	A	2.7
Max. back pressure	Pa	155
Min. ambient temperature	°C	-40
Max. ambient temperature	°C	40
Starting current	A	9.0

ml = Max. load · me = Max. efficiency · fa = Running at free air · cs = Customer specs · cu = Customer unit
 Subject to alterations

Data in accordance with ecodesign regulation EU 327/2011

		Actual	Request 2015		
01 Overall efficiency η_{es}	%	42.7	34.4	09 Power input P_e	kW 1.32
02 Measurement category		A		09 Air flow q_v	m ³ /h 13160
03 Efficiency category		Static		09 Pressure increase p_{fs}	Pa 155
04 Efficiency grade N		48.3	40	10 Speed (rpm) n	min ⁻¹ 885
05 Variable speed drive		No		11 Specific ratio*	1.00

Data definition with optimum efficiency.
 The ErP data is determined using a motor-impeller combination in a standardised measurement configuration.

* Specific ratio = $1 + p_g / 100\,000\text{ Pa}$

LU-177957



Technical features

Mass	32.5 kg
Size	800 mm
Motor size	138
Surface of rotor	Cast in aluminium
Material of blades	PP plastic
Material of wall ring	PP plastic
Streamer material	PP plastic
Material of guard grille	Steel, coated in black plastic (RAL9005)
Number of blades	5
Blade angle	0°
Direction of air flow	V
Direction of rotation	Clockwise, seen on rotor
Type of protection	IP54
Insulation class	"F"
Humidity (F) / environmental protection class (H)	H2
Note ambient temperature	If there is a risk of ice formation, the fan is only to be operated with a heating tape in the wall ring. Contact ebm-papst for more details. As a fan only suitable for use with industrial evaporators
Max. permissible ambient motor temp. (transp./ storage)	+70 °C
Min. permissible ambient motor temp. (transp./storage)	-40 °C
Mounting position	See fitting instructions
Condensation drainage holes	On rotor and stator sides
Operation mode	S1
Motor bearing	Ball bearing with anti-freezing grease
Touch current acc. IEC 60990 (measuring network Fig. 4, TN system)	<= 3.5 mA
Motor protection	Thermal overload protector (TOP) brought out, basic insulation
Cable exit	Axial
Protection class	I (if protective earth is connected by customer)
Product conforming to standard	EN 60034-1 (2010); CE
Approval	VDE; EAC

Product drawing

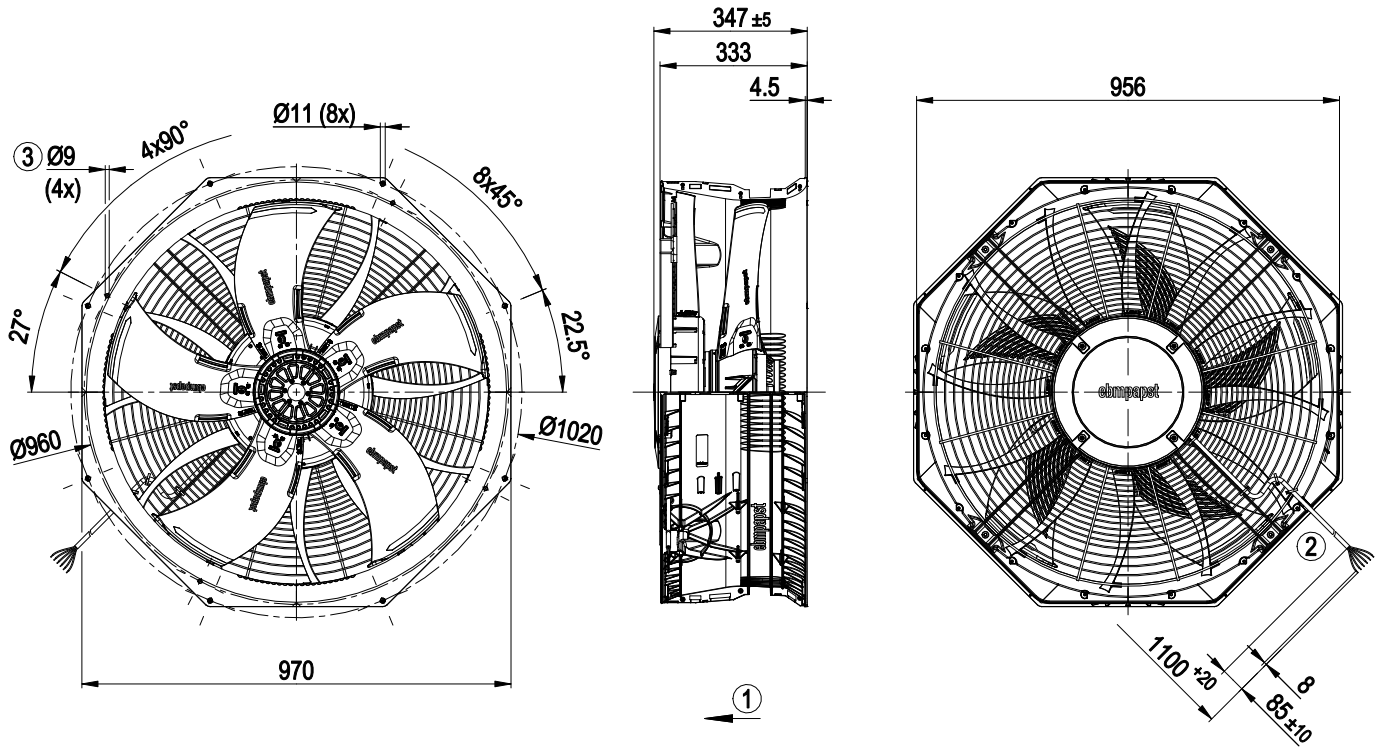

1	Direction of air flow "V"
2	Connection line halogen-free 6G 0.75 mm ² , 6x lead tips crimped
3	Mounting holes for FlowGrid



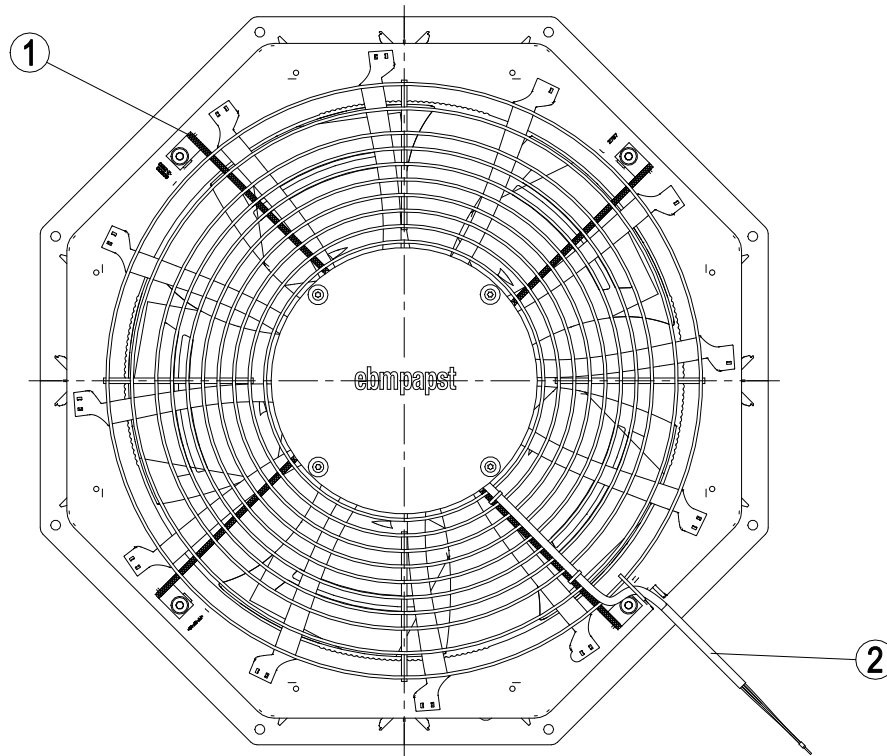

- | | |
|---|---|
| 1 | Installation position: shaft horizontal (install the support struts in X-position only as shown in illustration) or rotor on bottom |
| 2 | Cable exit must be at bottom right when shaft is installed in horizontal position. |

Connection screen

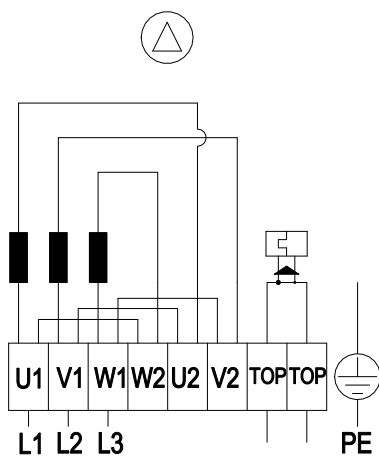

Three-phase motor equipped with TOP

Change in direction of rotation by reversing two phases

Δ	Delta connection
L1	black
L2	blue
L3	brown
TW	Thermal overload protector grey (2x)
PE	green/yellow

Charts: Air flow 50 Hz

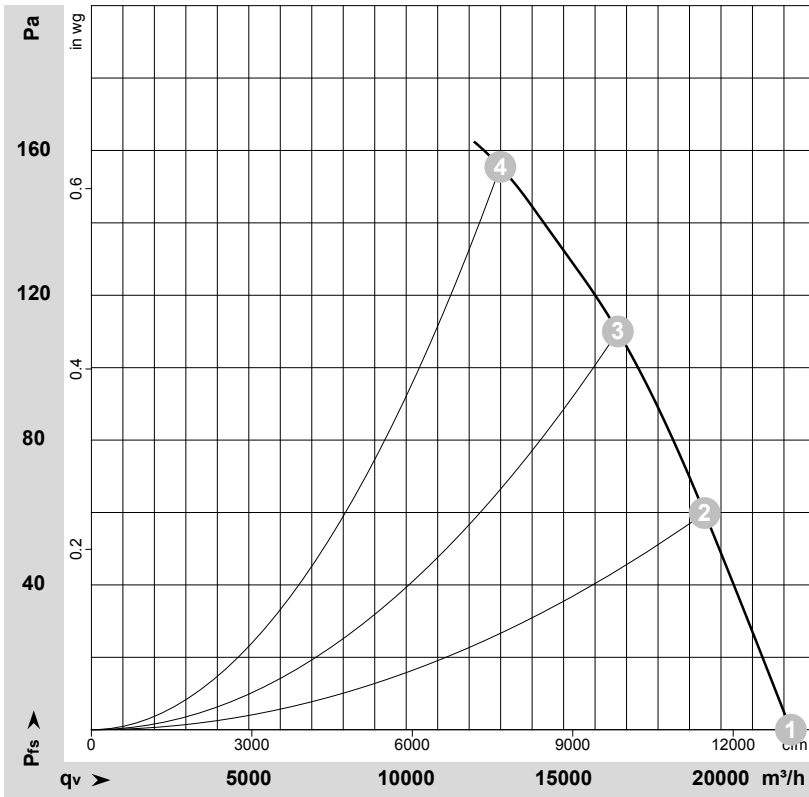

$\rho = 1.15 \text{ kg/m}^3 \pm 2 \%$

Measurement: LU-177957-1

Air performance measured as per ISO 5801 Installation category A. For detailed information on the measuring set-up, please contact ebmpapst. Suction-side noise levels: LwA measured as per ISO 13347 / LpA measured with 1m distance to fan axis. The values given are valid under the measuring conditions mentioned above and may vary according to the actual installation situation. With any deviation from the standard set-up, the specific values have to be checked and reviewed with the unit installed.

Measured values

	Conn.	U	f	n	Pe	I	LpA _{in}	LwA _{in}	LwA _{out}	qv	Pfs	qv	Pfs
		V	Hz	min ⁻¹	W	A	dB(A)	dB(A)	dB(A)	m ³ /h	Pa	cfm	in. wg
1	Δ	400	50	915	1030	2.36	68	76	76	22220	0	13080	0.00
2	Δ	400	50	905	1168	2.52	67	74	74	19480	60	11465	0.24
3	Δ	400	50	890	1269	2.65	67	74	74	16725	110	9845	0.44
4	Δ	400	50	880	1340	2.70	75	83	84	12990	155	7645	0.62

Conn. = Connection · U = Supply voltage · f = Frequency · n = Speed (rpm) · Pe = Power input · I = Current draw · LpA_{in} = Sound pressure level inlet side · LwA_{in} = Sound power level inlet side
 LwA_{out} = Sound power level outlet side · qv = Air flow · Pfs = Pressure increase

