

AC axial fan - HyBlade

sickle-shaped blades (S series)
with square full nozzle with AxiTop diffuser

W6D800-HD01-01 ebmpapst Datasheet
sales@fansco.com
www.fansco.com

Limited partnership · Headquarters Muldingen
Amtsgericht (court of registration) Stuttgart · HRA 590344

General partner Elektrobau Muldingen GmbH · Headquarters Muldingen
Amtsgericht (court of registration) Stuttgart · HRB 590142



Nominal data

Type	W6D800-HD01-01		
Motor	M6D138-LA		
Phase		3~	3~
Nominal voltage	VAC	400	400
Wiring		Δ	Y
Frequency	Hz	50	50
Method of obtaining data		ml	ml
Valid for approval/standard		CE	CE
Speed	min ⁻¹	880	670
Power consumption	W	1940	1210
Current draw	A	3.9	2.23
Max. back pressure	Pa	160	92
Min. ambient temperature	°C	-40	-40
Max. ambient temperature	°C	60	60
Starting current	A	13	4.3

ml = Max. load · me = Max. efficiency · fa = Free air · cs = Customer specification · ce = Customer equipment
Subject to change

Data according to ErP Directive

		Actual	Req. 2015			
01 Overall efficiency η_{es}	%	37.6	35.2	09 Power consumption P_e	kW	1.75
02 Measurement category		A		09 Air flow q_v	m ³ /h	17840
03 Efficiency category		Static		09 Pressure increase p_{fs}	Pa	133
04 Efficiency grade N		42.4	40	10 Speed n	min ⁻¹	900
05 Variable speed drive		No		11 Specific ratio*		1.00

Data obtained at optimum efficiency level.
The ErP data is determined using a motor-impeller combination in a standardized measurement setup.

* Specific ratio = $1 + p_g / 100\,000\text{ Pa}$

LU-153379



AC axial fan - HyBlade

sickle-shaped blades (S series)
with square full nozzle with AxiTop diffuser

Technical description

Weight	46.8 kg
Fan size	800 mm
Rotor surface	Cast in aluminum
Terminal box material	PC plastic
Blade material	Sheet aluminum insert, sprayed with PP plastic
Support ring material	Steel, coated with black plastic (RAL 9005)
Fan housing material	Sheet steel, pre-galvanized and coated with black plastic (RAL 9005)
Guard grille material	Steel, coated with black plastic (RAL 9005)
Outer diffuser material	PP plastic
Internal diffuser material including cover	PP plastic
Number of blades	5
Blade pitch	0°
Airflow direction	"V"
Direction of rotation	Clockwise, viewed toward rotor
Degree of protection	IP54
Insulation class	"F"
Moisture (F) / Environmental (H) protection class	F3-1
Max. permitted ambient temp. for motor (transport/storage)	+80 °C
Min. permitted ambient temp. for motor (transport/storage)	-40 °C
Installation position	Any
Condensation drainage holes	On rotor and stator sides
Mode	S1
Motor bearing	Ball bearing
Touch current according to IEC 60990 (measuring circuit Fig. 4, TN system)	≤ 3.5 mA
Electrical hookup	Via terminal box
Motor protection	Thermal overload protector (TOP) with basic insulation
With cable	Lateral
Protection class	I (with customer connection of protective earth)
Conformity with standards	EN 60034-1 (2010); EN 61800-5-1; CE
Approval	EAC; VDE



AC axial fan - HyBlade

sickle-shaped blades (S series)
with square full nozzle with AxiTop diffuser

Product drawing

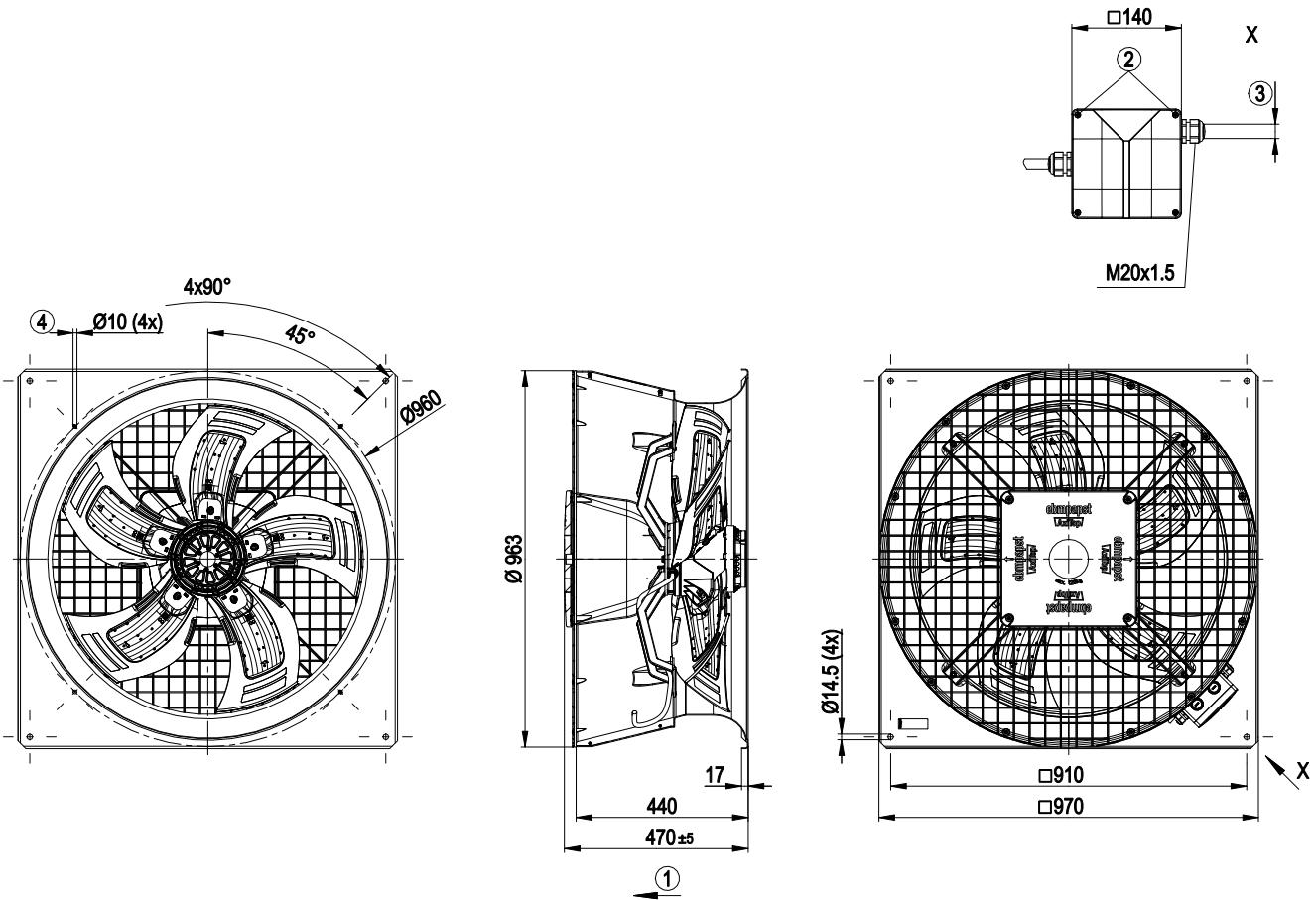

1	Direction of air flow "V"
2	Tightening torque 1.5 ± 0.2 Nm
3	Cable diameter: min. 7 mm, max. 14 mm; tightening torque 2 ± 0.3 Nm
4	Mounting holes for FlowGrid



AC axial fan - HyBlade

sickle-shaped blades (S series)
with square full nozzle with AxiTop diffuser

Connection diagram



Δ	Delta connection	Y	Star connection	L1	= U1 = black
L2	= V1 = blue	L3	= W1 = brown	W2	yellow
U2	green	V2	white	TOP	2x gray
PE	green/yellow				



AC axial fan - HyBlade

sickle-shaped blades (S series)
with square full nozzle with AxiTop diffuser

Curves: Air performance 50 Hz

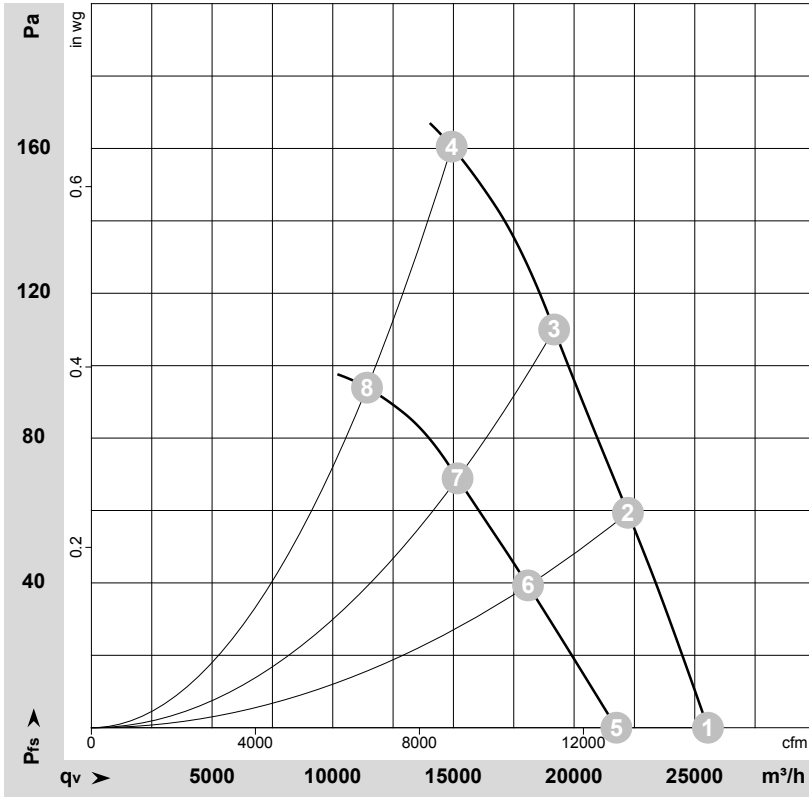

$\rho = 1.15 \text{ kg/m}^3 \pm 2 \%$

Measurement: LU-153379-1
Measurement: LU-153382-1

Air performance measured according to ISO 5801 installation category A. For detailed information on the measurement setup, contact ebmpapst. Intake sound level: Sound power level according to ISO 13347 / sound pressure level measured at 1 m distance from fan axis. The values given are valid under the specified measuring conditions and may vary due to conditions of installation. For deviations from the standard configuration, the parameters have to be checked on the installed unit.

Measured values

	Wired	U	f	n	P _e	I	LpA _{in}	LwA _{in}	LwA _{out}	qv	p _{fs}
		V	Hz	min ⁻¹	W	A	dB(A)	dB(A)	dB(A)	m ³ /h	Pa
1	Δ	400	50	930	1299	3.03	68	75	76	25545	0
2	Δ	400	50	915	1533	3.32	66	73	73	22230	60
3	Δ	400	50	905	1689	3.51	66	73	74	19175	110
4	Δ	400	50	880	1940	3.90	69	76	76	14930	160
5	Y	400	50	790	982	1.80	64	71	71	21750	0
6	Y	400	50	750	1094	2.02	61	68	68	18090	40
7	Y	400	50	715	1160	2.15	60	67	67	15170	69
8	Y	400	50	670	1210	2.23	62	69	69	11420	94

Wired = Wiring · U = Power supply · f = Frequency · n = Speed · P_e = Power consumption · I = Current draw · LpA_{in} = Sound pressure level intake side · LwA_{in} = Sound power level intake side
LwA_{out} = Sound power level outlet side · qv = Air flow · p_{fs} = Pressure increase

