

# AC axial fan

sickle-shaped blades (S series)

with square full nozzle

W6D800-GK05-41 ebmpapst Datasheet

sales@fansco.com

www.fansco.com

Limited partnership · Headquarters Muldingen

Amtsgericht (court of registration) Stuttgart · HRA 590344

General partner Elektrobau Muldingen GmbH · Headquarters Muldingen

Amtsgericht (court of registration) Stuttgart · HRB 590142



## Nominal data

Type	W6D800-GK05-41				
Motor	M6D138-LA				
Phase		3~	3~	3~	3~
Nominal voltage	VAC	230	277	400	480
Wiring		Δ	Δ	Y	Y
Frequency	Hz	50	60	50	60
Method of obtaining data		ml	ml	ml	ml
Valid for approval/standard		CE	CE	CE	CE
Speed	min <sup>-1</sup>	905	1085	905	1085
Power consumption	W	1530	2160	1530	2160
Current draw	A	5.98	6.7	3.46	3.87
Max. back pressure	Pa	170	150	170	150
Min. ambient temperature	°C	-40	-40	-40	-40
Max. ambient temperature	°C	60	60	60	60
Starting current	A	22		13	14

ml = Max. load · me = Max. efficiency · fa = Free air · cs = Customer specification · ce = Customer equipment

Subject to change

## Data according to ErP Directive

		Actual	Req. 2015		
01 Overall efficiency $\eta_{es}$	%	38.2	34.5	09 Power consumption $P_e$	kW 1.33
02 Measurement category	A			09 Air flow $q_v$	m <sup>3</sup> /h 15200
03 Efficiency category	Static			09 Pressure increase $p_{fs}$	Pa 122
04 Efficiency grade N	43.7	40		10 Speed n	min <sup>-1</sup> 920
05 Variable speed drive	No			11 Specific ratio*	1.00

Data obtained at optimum efficiency level.

The ErP data is determined using a motor-impeller combination in a standardized measurement setup.

\* Specific ratio =  $1 + p_g / 100\,000\text{ Pa}$ 

LU-101334



# AC axial fan

sickle-shaped blades (S series)

with square full nozzle

## Technical description

Weight	46 kg
Fan size	800 mm
Rotor surface	Cast in aluminum
Terminal box material	PP plastic
Blade material	Die-cast aluminum
Fan housing material	Sheet steel, galvanized and coated with traffic white plastic (RAL 9016)
Guard grille material	Steel, coated with black plastic (RAL 9005)
Number of blades	5
Blade pitch	0°
Airflow direction	"V"
Direction of rotation	Clockwise, viewed toward rotor
Degree of protection	IP54
Insulation class	"F"
Moisture (F) / Environmental (H) protection class	F3-1
Max. permitted ambient temp. for motor (transport/storage)	+ 80 °C
Min. permitted ambient temp. for motor (transport/storage)	- 40 °C
Installation position	Any
Condensation drainage holes	On rotor and stator sides
Mode	S1
Motor storage	Ball bearing
Touch current according to IEC 60990 (measuring circuit Fig. 4, TN system)	<= 3.5 mA
Electrical hookup	Via terminal box
Motor protection	Thermal overload protector (TOP) externally wired
With cable	Axial
Protection class	I (with customer connection of protective earth)
Conformity with standards	EN 60034-1 (2010); EN 61800-5-1; CE
Approval	CSA C22.2 No. 100; EAC; UL 1004-1



# AC axial fan

sickle-shaped blades (S series)  
with square full nozzle

## Product drawing

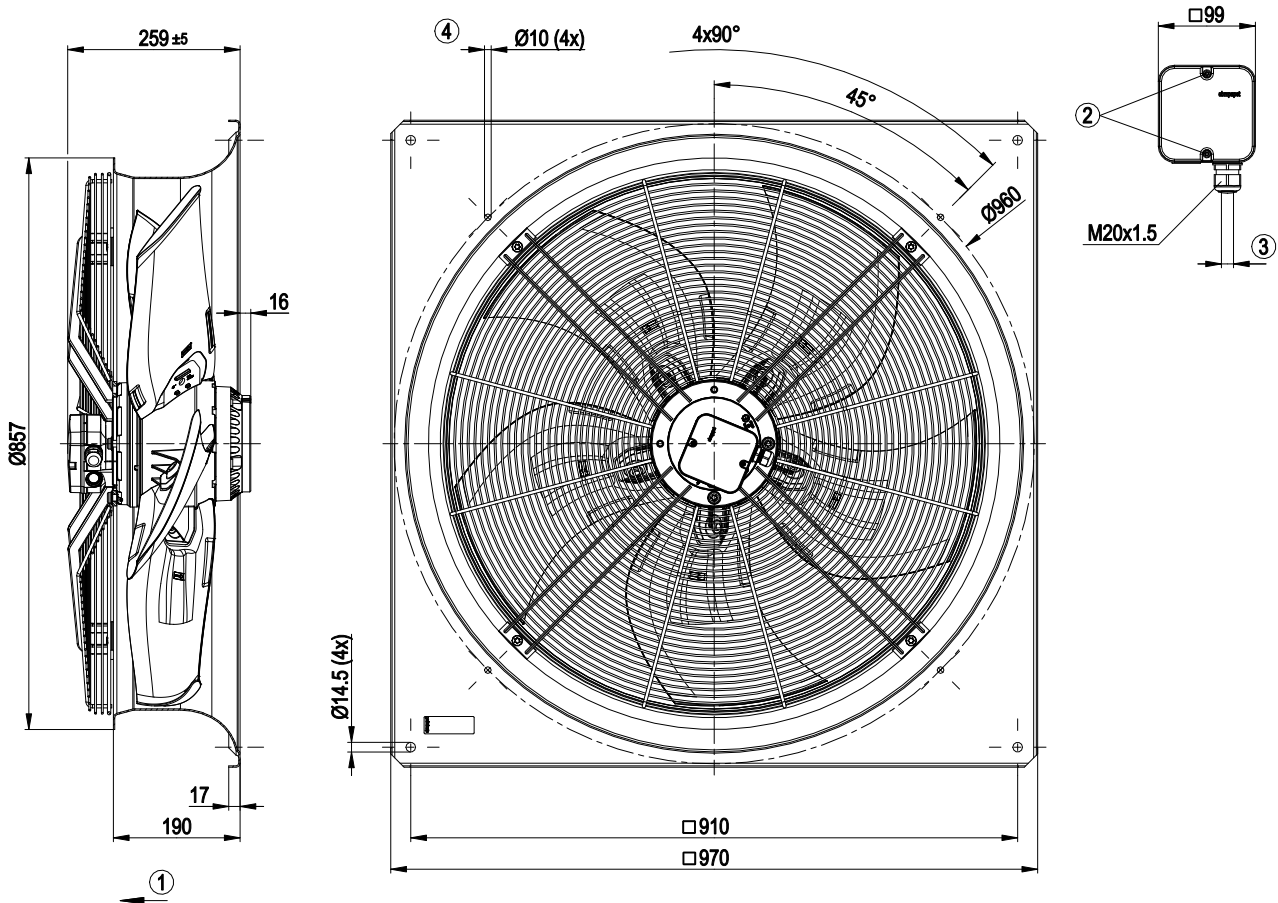

1	Direction of air flow "V"
2	Tightening torque $1.5 \pm 0.2$ Nm
3	Cable diameter min. 7 mm, max. 14 mm; tightening torque $2 \pm 0.3$ Nm
4	Mounting holes for FlowGrid



# AC axial fan

sickle-shaped blades (S series)  
with square full nozzle

## Connection diagram



Δ	Delta connection	Y	Star connection	L1	= U1 = black
L2	= V1 = blue	L3	= W1 = brown	W2	yellow
U2	green	V2	white	TOP	2x gray
PE	green/yellow				



# AC axial fan

sickle-shaped blades (S series)  
with square full nozzle

## Curves: Air performance 50 Hz

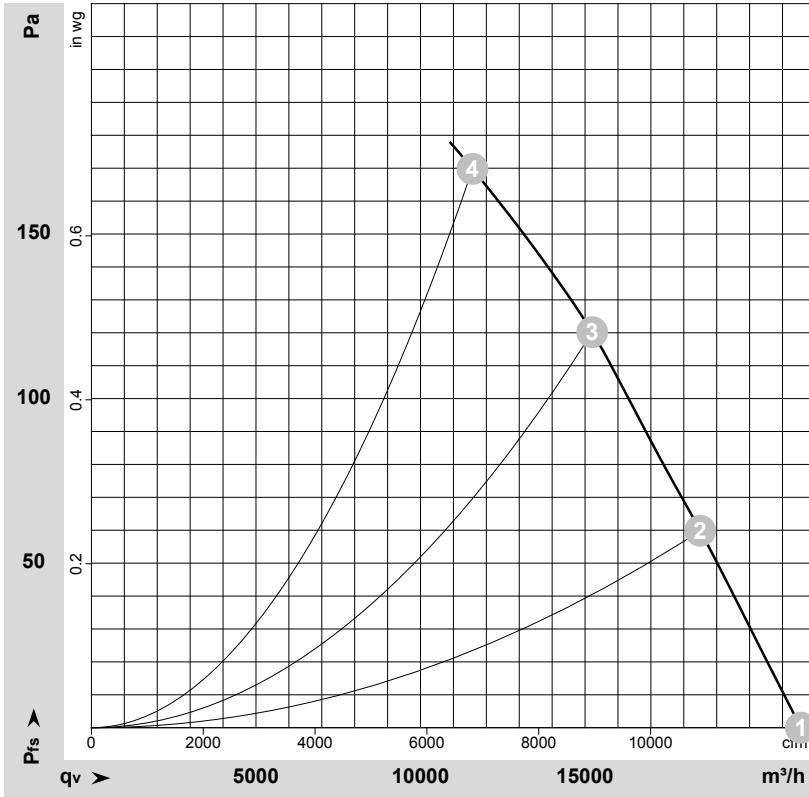

$\rho = 1,15 \text{ kg/m}^3 \pm 2\%$

Measurement: LU-101334

Air performance measured according to ISO 5801 installation category A. For detailed information on the measurement setup, contact ebm-papst. Intake sound level: Sound power level according to ISO 13347 / sound pressure level measured at 1 m distance from fan axis. The values given are valid under the specified measuring conditions and may vary due to conditions of installation. For deviations from the standard configuration, the parameters have to be checked on the installed unit.

## Measured values

	Wired	U	f	n	P <sub>e</sub>	I	LpA <sub>in</sub>	LwA <sub>in</sub>	qv	P <sub>fs</sub>
		V	Hz	min <sup>-1</sup>	W	A	dB(A)	dB(A)	m <sup>3</sup> /h	Pa
1	Y	400	50	950	968	2.84	69	75	21560	0
2	Y	400	50	935	1190	3.06	65	72	18500	60
3	Y	400	50	920	1338	3.22	67	73	15215	120
4	Y	400	50	905	1530	3.46	70	77	11580	170

Wired = Wiring · U = Power supply · f = Frequency · n = Speed · P<sub>e</sub> = Power consumption · I = Current draw · LpA<sub>in</sub> = Sound pressure level intake side · LwA<sub>in</sub> = Sound power level intake side  
qv = Air flow · P<sub>fs</sub> = Pressure increase



# AC axial fan

sickle-shaped blades (S series)  
with square full nozzle

## Curves: Air performance 60 Hz

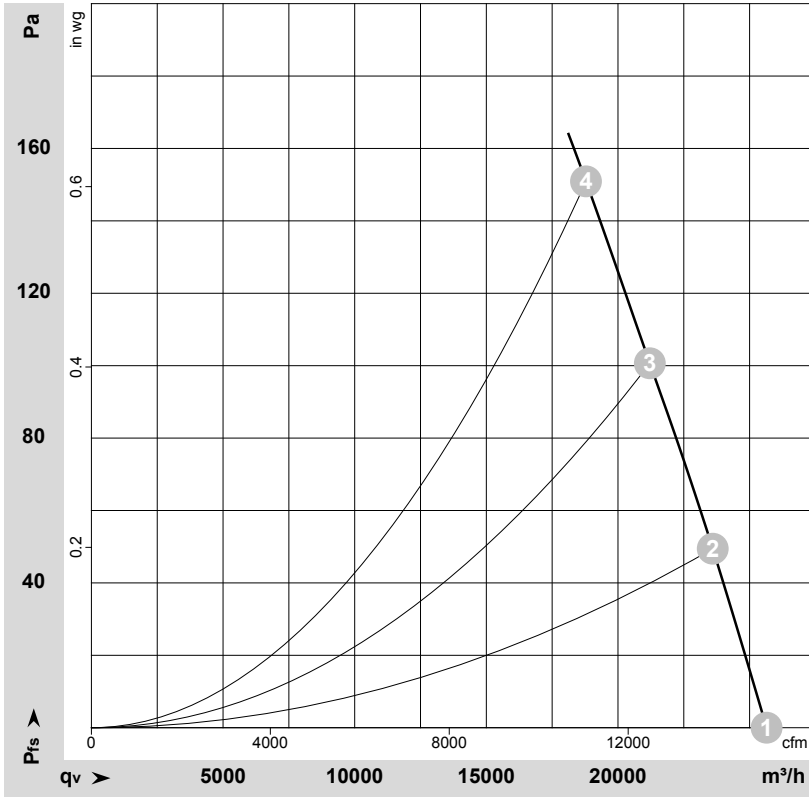

$\rho = 1,15 \text{ kg/m}^3 \pm 2\%$

Measurement: LU-101330

Air performance measured according to ISO 5801 installation category A. For detailed information on the measurement setup, contact ebm-papst. Intake sound level: Sound power level according to ISO 13347 / sound pressure level measured at 1 m distance from fan axis. The values given are valid under the specified measuring conditions and may vary due to conditions of installation. For deviations from the standard configuration, the parameters have to be checked on the installed unit.

## Measured values

	Wired	U	f	n	P <sub>e</sub>	I	LpA <sub>in</sub>	LwA <sub>in</sub>	qv	P <sub>fs</sub>
		V	Hz	min <sup>-1</sup>	W	A	dB(A)	dB(A)	m <sup>3</sup> /h	Pa
1	Y	480	60	1125	1600	3.26	72	79	25645	0
2	Y	480	60	1110	1827	3.49	69	76	23600	50
3	Y	480	60	1095	2014	3.70	68	74	21210	100
4	Y	480	60	1085	2160	3.87	69	76	18785	150

Wired = Wiring · U = Power supply · f = Frequency · n = Speed · P<sub>e</sub> = Power consumption · I = Current draw · LpA<sub>in</sub> = Sound pressure level intake side · LwA<sub>in</sub> = Sound power level intake side  
qv = Air flow · P<sub>fs</sub> = Pressure increase

