

# AC axial fan - HyBlade

sickle-shaped blades (S series)

with square full nozzle

W6D800-GE05-03 ebmpapst Datasheet

sales@fansco.com

www.fansco.com

Limited partnership · Headquarters Mulfingen

Amtsgericht (court of registration) Stuttgart · HRA 590344

General partner Elektrobau Mulfingen GmbH · Headquarters Mulfingen

Amtsgericht (court of registration) Stuttgart · HRB 590142

## Nominal data

<b>Type</b>	<b>W6D800-GE05-03</b>										
<b>Motor</b>	<b>M6D138-LA</b>										
Phase		3~	3~	3~	3~	3~	3~	3~	3~	3~	3~
Nominal voltage	VAC	220	230	230	277	380	400	400	440	440	480
Wiring		Δ	Δ	Δ	Δ	Y	Y	Y	Y	Y	Y
Frequency	Hz	60	50	60	60	60	50	60	50	60	60
Method of obtaining data		ml	ml	ml	ml	ml	ml	ml	ml	ml	ml
Valid for approval/standard		CE	CE	CE	CE	CE	CE	CE	CE	CE	CE
Speed (rpm)	min <sup>-1</sup>	1010	905	1030	1080	1010	905	1030	925	1060	1080
Power consumption	W	1930	1570	1990	2180	1930	1570	1990	1650	2100	2180
Current draw	A	6.85	5.92	6.5	6.6	3.95	3.42	3.78	3.7	3.85	3.8
Max. back pressure	Pa	130	170	135	150	130	170	135	180	140	150
Max. back pressure	in. wg	0.52	0.68	0.54	0.6	0.52	0.68	0.54	0.72	0.56	0.6
Min. ambient temperature	°C	-40	-40	-40	-40	-40	-40	-40	-40	-40	-40
Max. ambient temperature	°C	60	65	60	60	60	65	60	65	60	60
Starting current	A		22	17.5	24		13	10	15	12	14

ml = Max. load · me = Max. efficiency · fa = Free air · cs = Customer specification · ce = Customer equipment  
 Subject to change

## Data according to Commission Regulation (EU) 327/2011

	Actual	Req. 2015				
01 Overall efficiency $\eta_{es}$	%	37.4	34.6	09 Power consumption $P_e$	kW	1.38
02 Measurement category		A		09 Air flow $q_v$	m <sup>3</sup> /h	14570
03 Efficiency category		Static		09 Pressure increase $p_{fs}$	Pa	128
04 Efficiency grade N		42.8	40	10 Speed (rpm) n	min <sup>-1</sup>	920
05 Variable speed drive		No		11 Specific ratio*		1.00

Data obtained at optimum efficiency level.  
 The ErP data is determined using a motor-impeller combination in a standardized measurement setup.

\* Specific ratio =  $1 + p_{fs} / 100\,000\text{ Pa}$

LU-114552



# AC axial fan - HyBlade

sickle-shaped blades (S series)

with square full nozzle

## Technical description

Weight	44 kg
Size	800 mm
Motor size	138
Rotor surface	Cast in aluminum
Terminal box material	PP plastic
Blade material	Sheet aluminum insert, sprayed with PP plastic
Fan housing material	Sheet steel, galvanized and coated with black plastic (RAL 9005)
Guard grille material	Steel, coated with black plastic (RAL 9005)
Number of blades	5
Blade pitch	-5°
Airflow direction	V
Direction of rotation	Clockwise, viewed toward rotor
Degree of protection	IP54
Insulation class	"F"
Moisture (F) / Environmental (H) protection class	H2
Ambient temperature note	Occasional start-up at temperatures between -40°C and -25°C is permitted. For continuous operation at ambient temperatures below -25°C (such as refrigeration applications), use must be made of a fan design with special low-temperature bearings.
Max. permitted ambient temp. for motor (transport/storage)	+80 °C
Min. permitted ambient temp. for motor (transport/storage)	-40 °C
Installation position	Any
Condensation drainage holes	On rotor and stator sides
Mode	S1
Motor bearing	Ball bearing
Touch current according to IEC 60990 (measuring circuit Fig. 4, TN system)	≤ 3.5 mA
Electrical hookup	Terminal box
Motor protection	Thermal overload protector (TOP) with basic insulation
With cable	Axial
Protection class	I (with customer connection of protective earth)
Conformity with standards	EN 60034-1 (2010); CE
Approval	UL 1004-1; EAC; CSA C22.2 No. 100



# AC axial fan - HyBlade

sickle-shaped blades (S series)

with square full nozzle

## Product drawing

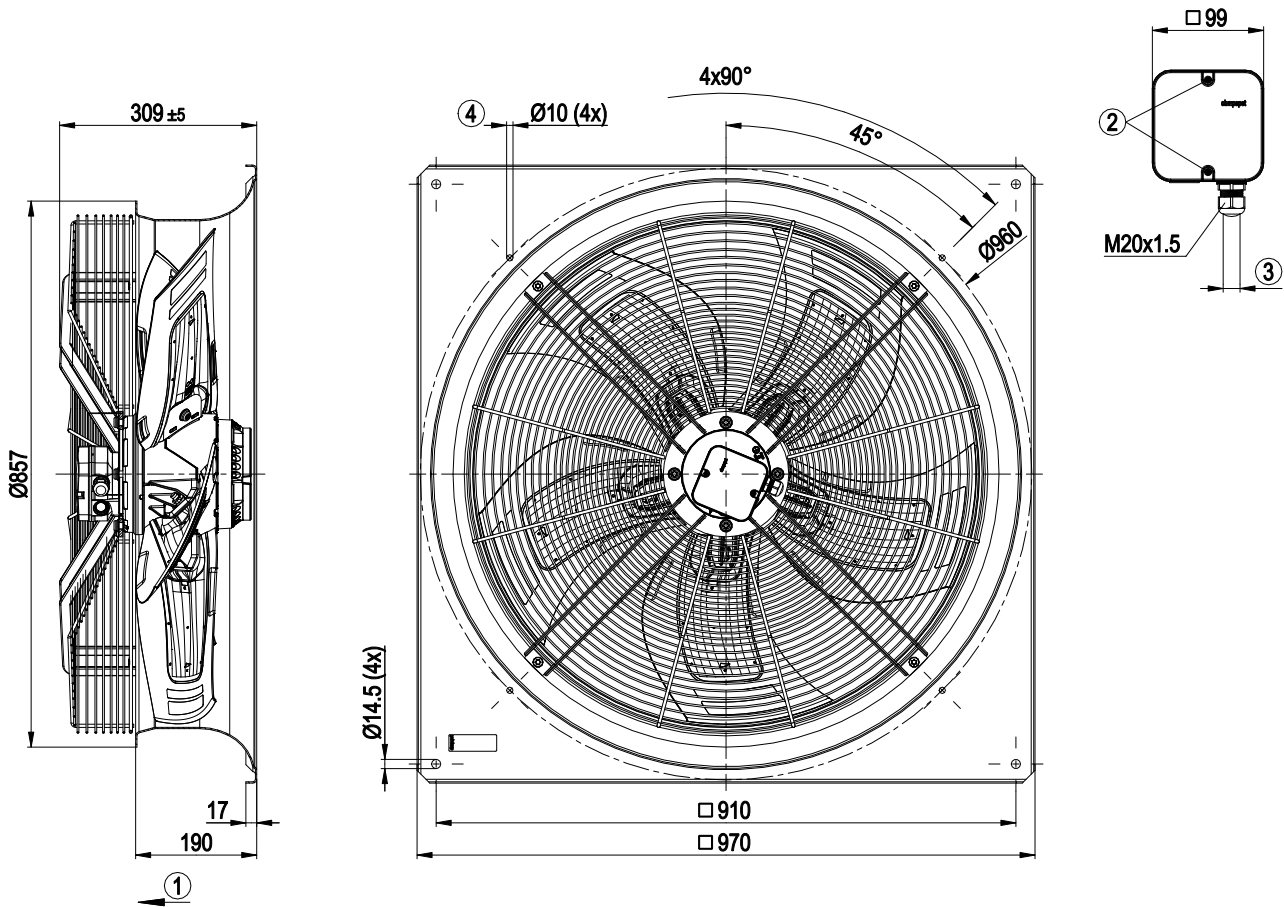

1	Direction of air flow "V"
2	Tightening torque $1.5 \pm 0.2$ Nm
3	Cable diameter min. 7 mm, max. 14 mm, tightening torque $2 \pm 0.3$ Nm
4	Mounting holes for FlowGrid



# AC axial fan - HyBlade

sickle-shaped blades (S series)

with square full nozzle

## Connection diagram



Δ	Delta connection	Y	Star connection	L1	= U1 = black
L2	= V1 = blue	L3	= W1 = brown	W2	yellow
U2	green	V2	white	TOP	2x gray
PE	green/yellow				



# AC axial fan - HyBlade

sickle-shaped blades (S series)

with square full nozzle

## Curves: Air performance 50 Hz

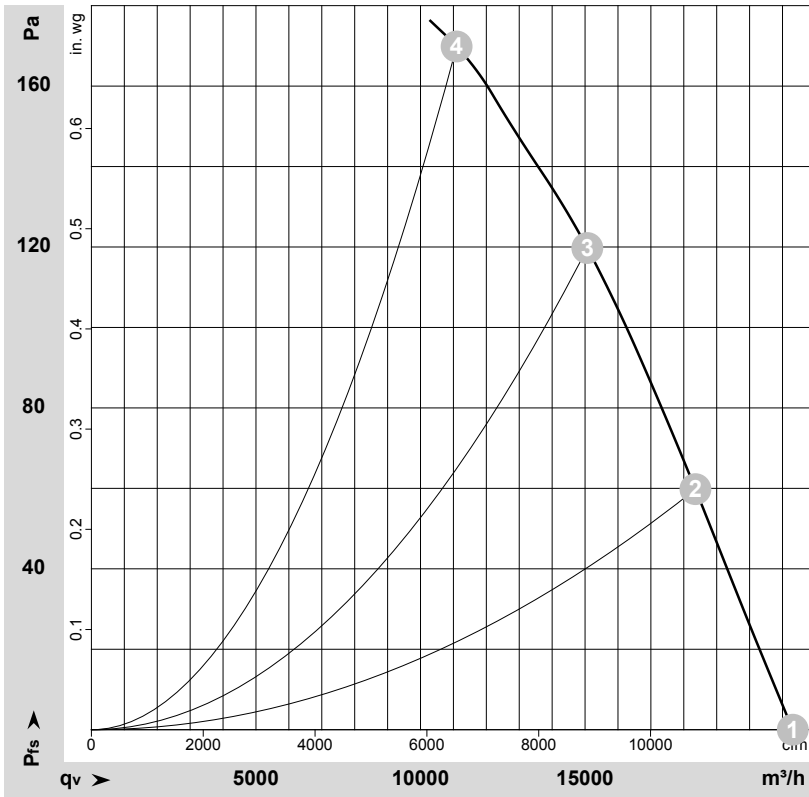

$\rho = 1.15 \text{ kg/m}^3 \pm 2 \%$

Measurement: LU-114552-1

Air performance measured according to ISO 5801 installation category A. For detailed information on the measurement setup, contact ebmpapst. Intake sound level: Sound power level according to ISO 13347 / sound pressure level measured at 1 m distance from fan axis. The values given are valid under the specified measuring conditions and may vary due to conditions of installation. For deviations from the standard configuration, the parameters have to be checked on the installed unit.

## Measured values

	Wired	U	f	n	P <sub>e</sub>	I	LpA <sub>in</sub>	LwA <sub>in</sub>	LwA <sub>out</sub>	q <sub>v</sub>	p <sub>fs</sub>	q <sub>v</sub>	p <sub>fs</sub>
		V	Hz	min <sup>-1</sup>	W	A	dB(A)	dB(A)	dB(A)	m <sup>3</sup> /h	Pa	cfm	in. wg
1	Y	400	50	950	992	2.81	67	73	73	21310	0	12545	0.00
2	Y	400	50	935	1203	3.00	63	70	69	18355	60	10805	0.24
3	Y	400	50	920	1364	3.21	67	73	72	15070	120	8870	0.48
4	Y	400	50	905	1570	3.42	72	79	79	11095	170	6530	0.68

Wired = Wiring · U = Voltage · f = Frequency · n = Speed (rpm) · P<sub>e</sub> = Power consumption · I = Current draw · LpA<sub>in</sub> = Sound pressure level intake side · LwA<sub>in</sub> = Sound power level intake side  
 LwA<sub>out</sub> = Sound power level outlet side · q<sub>v</sub> = Air flow · p<sub>fs</sub> = Pressure increase



# AC axial fan - HyBlade

sickle-shaped blades (S series)

with square full nozzle

## Curves: Air performance 60 Hz

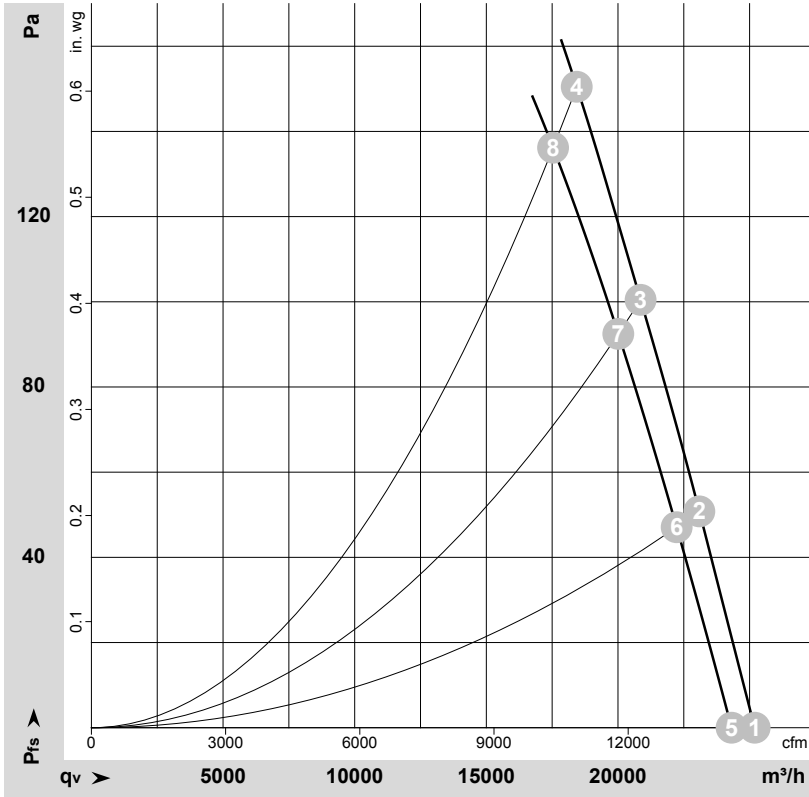

$\rho = 1.15 \text{ kg/m}^3 \pm 2 \%$

Measurement: LU-114632-1  
Measurement: LU-114637-1

Air performance measured according to ISO 5801 installation category A. For detailed information on the measurement setup, contact ebmpapst. Intake sound level: Sound power level according to ISO 13347 / sound pressure level measured at 1 m distance from fan axis. The values given are valid under the specified measuring conditions and may vary due to conditions of installation. For deviations from the standard configuration, the parameters have to be checked on the installed unit.

## Measured values

	Wired	U	f	n	P <sub>e</sub>	I	LpA <sub>in</sub>	LwA <sub>in</sub>	LwA <sub>out</sub>	q <sub>v</sub>	p <sub>fs</sub>	q <sub>v</sub>	p <sub>fs</sub>
		V	Hz	min <sup>-1</sup>	W	A	dB(A)	dB(A)	dB(A)	m <sup>3</sup> /h	Pa	cfm	in. wg
1	Y	480	60	1125	1619	3.22	71	78	78	25190	0	14825	0.00
2	Y	480	60	1110	1826	3.45	68	75	75	23090	50	13590	0.20
3	Y	480	60	1095	2024	3.67	68	75	74	20860	100	12275	0.40
4	Y	480	60	1080	2180	3.80	70	77	75	18435	150	10850	0.60
5	Y	400	60	1090	1512	3.11	70	76	77	24315	0	14310	0.00
6	Y	400	60	1070	1695	3.40	67	74	74	22230	49	13085	0.20
7	Y	400	60	1050	1841	3.64	68	74	74	20015	92	11780	0.37
8	Y	400	60	1030	1990	3.78	69	75	74	17535	135	10320	0.54

Wired = Wiring · U = Voltage · f = Frequency · n = Speed (rpm) · P<sub>e</sub> = Power consumption · I = Current draw · LpA<sub>in</sub> = Sound pressure level intake side · LwA<sub>in</sub> = Sound power level intake side  
LwA<sub>out</sub> = Sound power level outlet side · q<sub>v</sub> = Air flow · p<sub>fs</sub> = Pressure increase

