

ebm-papst Ventilator (Shanghai) Co.,Ltd.

No.418, Hua Jing Road, Wai Gao Qiao Free Trade Zone, Pudong

83

W6D800-GD01-01/F11 ebmpapst Datasheet

sales@fansco.com

www.fansco.com

**Nominal data**

Type	W6D800-GD01-01/F11		
Motor	M6D138-LA		
Phase		3~	3~
Nominal voltage	VAC	400	400
Connection		Δ	Y
Frequency	Hz	50	50
Type of data definition		ml	ml
Valid for approval / standard		--	--
Speed	min ⁻¹	880	670
Power input	W	1940	1210
Current draw	A	3.9	2.23
Max. back pressure	Pa	160	92
Min. ambient temperature	°C	-40	-40
Max. ambient temperature	°C	60	60
Starting current	A	13	4.3

ml = Max. load · me = Max. efficiency · fa = Running at free air · cs = Customer specs · cu = Customer unit
Subject to alterations

Data according to ErP directive

Installation category	A
Efficiency category	Static
Variable speed drive	No
Specific ratio*	1.00

* Specific ratio = $1 + p_{fs} / 100\,000\text{ Pa}$

		Actual	Request 2013	Request 2015
Overall efficiency η_{es}	%	35.2	31.2	35.2
Efficiency grade N		40	36	40
Power input P_e	kW	1.72		
Air flow q_v	m ³ /h	17215		
Pressure increase p_{fs}	Pa	124		
Speed n	min ⁻¹	905		

Data definition with optimum efficiency. LU-122313
The ErP data is determined using a motor-impeller combination in a standardised measurement configuration.



AC axial fan - HyBlade®

sickled blades (S series)

with full square nozzle

Technical features

Mass	44 kg
Size	800 mm
Surface of rotor	Cast in aluminium
Material of terminal box	PP plastic
Material of blades	Aluminium sheet insert, sprayed with PP plastic
Material of wall ring	Sheet steel, pre-galvanised and coated in black plastic (RAL 9005)
Material of guard grille	Steel, coated in black plastic (RAL9005)
Number of blades	5
Blade angle	0
Direction of air flow	"V"
Direction of rotation	Clockwise, seen on rotor
Type of protection	IP 54
Insulation class	"F"
Humidity class	F3-1
Max. permissible ambient motor temp. (transp./ storage)	+ 80 °C
Min. permissible ambient motor temp. (transp./storage)	- 40 °C
Mounting position	Any
Condensate discharge holes	On rotor and stator sides
Operation mode	S1
Motor bearing	Ball bearing
Touch current acc. IEC 60990 (measuring network Fig. 4, TN system)	<= 3.5 mA
Electrical leads	Via terminal box
Motor protection	Thermal overload protector (TOP) brought out
Cable exit	Axial
Protection class	I (if protective earth is connected by customer)
Product conforming to standard	EN60034;EN61800-5-1;
Approval	



AC axial fan - HyBlade®

sickled blades (S series)

with full square nozzle

Product drawing

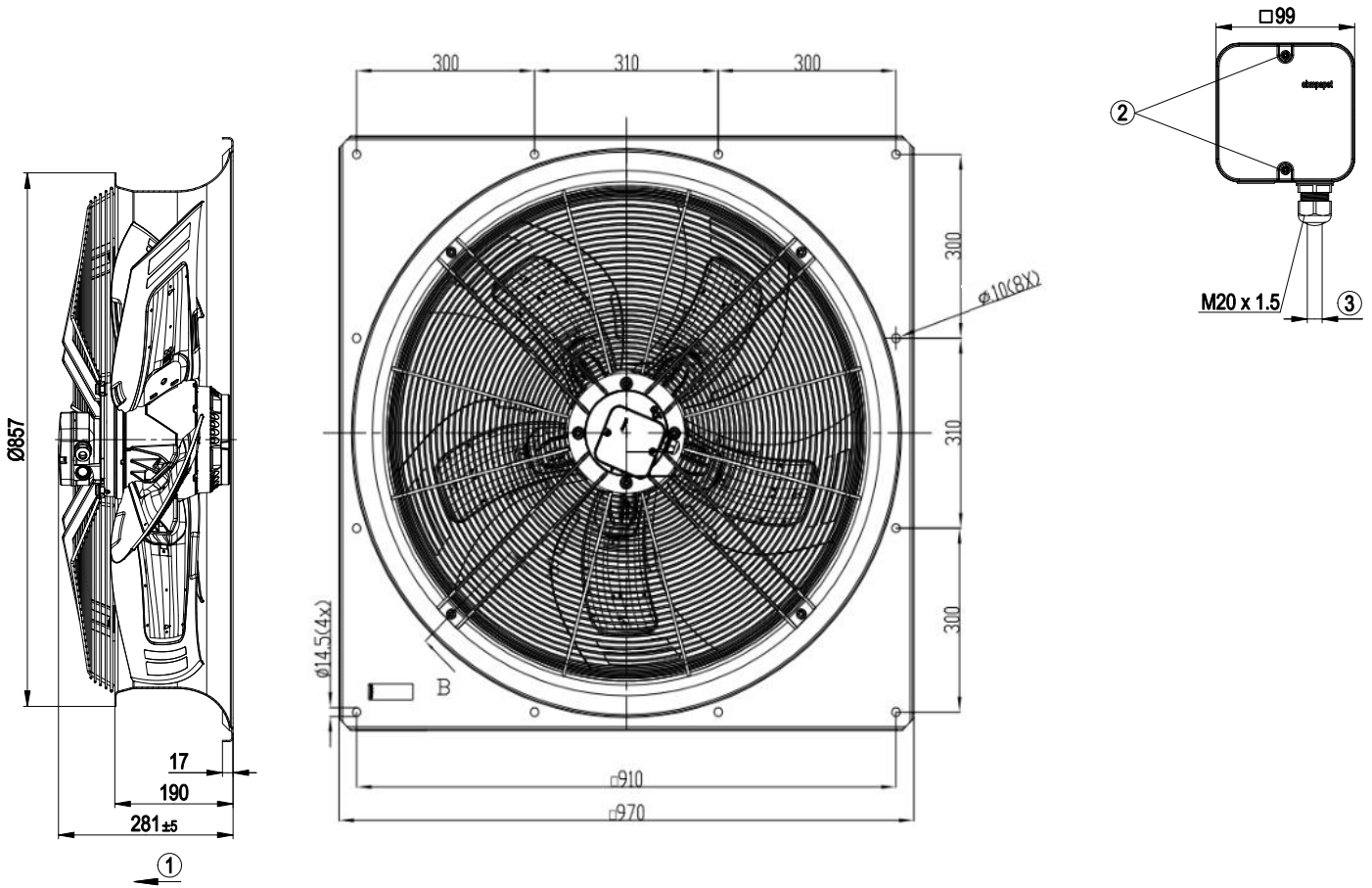

1	Direction of air flow "V"
2	Tightening torque 1.5 ± 0.2 Nm
3	Cable diameter: min. 7 mm, max. 14 mm, tightening torque: 2 ± 0.3 Nm



AC axial fan - HyBlade®

sickled blades (S series)

with full square nozzle

Connection screen

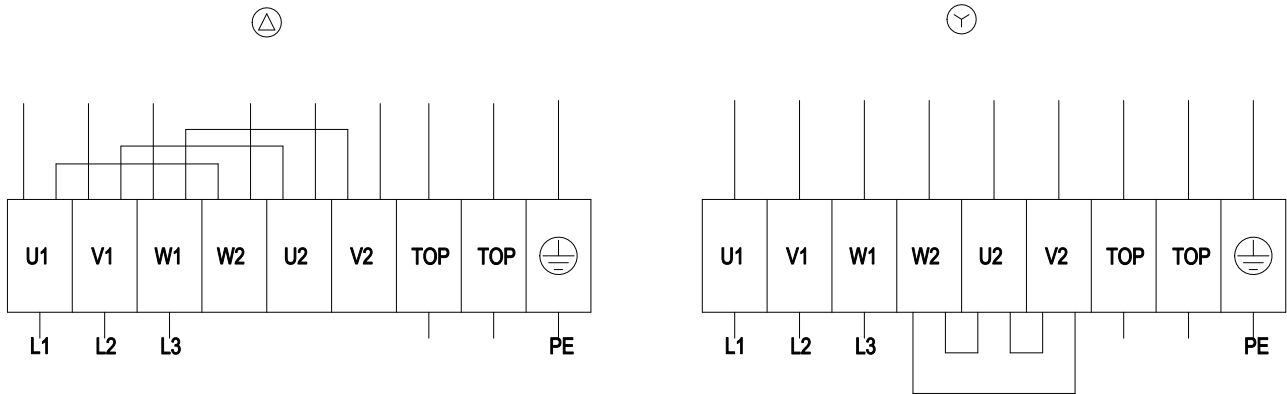

Δ	Delta connection	Y	Star connection	L1	= U1 = black
L2	= V1 = blue	L3	= W1 = brown	W2	yellow
U2	green	V2	white	TOP	2 x grey
PE	green/yellow				



Charts: Air flow 50 Hz

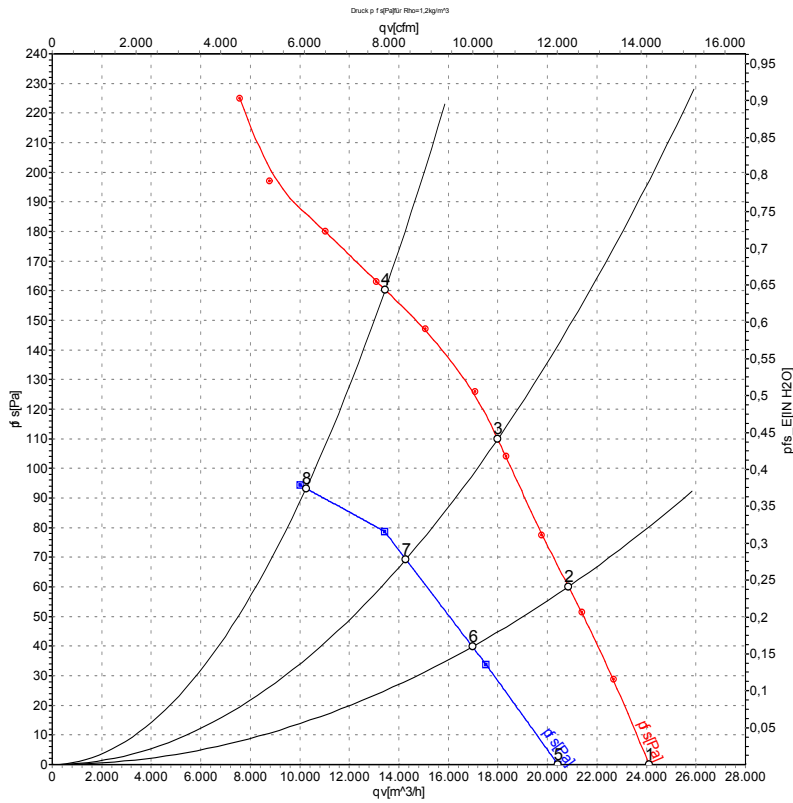

Air performance measured as per ISO 5801 Installation category A. For detailed information on the measuring set-up, please contact ebmpapst. Suction-side noise levels: LwA measured as per ISO 13347 / LpA measured with 1m distance to fan axis. The values given are valid under the measuring conditions mentioned above and may vary according to the actual installation situation. With any deviation from the standard set-up, the specific values have to be checked and reviewed with the unit installed.

Measured values

	Conn.	U	f	n	P _e	I	LpA _{in}	LwA _{in}	LwA _{out}	qv	p _{fs}
		V	Hz	min ⁻¹	W	A	dB(A)	dB(A)	dB(A)	m ³ /h	Pa
1	Δ	400	50	925	1380	3.30	65	72	72	24110	0
2	Δ	400	50	910	1581	3.44	65	72	71	20850	60
3	Δ	400	50	900	1720	3.60	66	73	72	17990	110
4	Δ	400	50	880	1940	3.90	70	77	76	13450	160
5	Y	400	50	780	1000	1.85	61	68	67	20430	0
6	Y	400	50	740	1079	1.98	60	66	66	16980	40
7	Y	400	50	710	1129	2.08	60	67	66	14290	69
8	Y	400	50	670	1210	2.23	62	70	69	10250	92

Conn. = Connection · U = Supply voltage · f = Frequency · n = Speed · P_e = Power input · I = Current draw · LpA_{in} = Sound pressure level inlet side · LwA_{in} = Sound power level inlet side · LwA_{out} = Sound power level outlet side · qv = Air flow · p_{fs} = Pressure increase

