

AC axial fan

sickle-shaped blades (S series)

with square full nozzle

W6D800-DE05-04 ebmpapst Datasheet FansCo

sales@fansco.com

www.fansco.com

Nominal data

Type	W6D800-DE05-04				
Motor	M6D138-LA				
Phase		3~	3~	3~	3~
Nominal voltage	VAC	230	277	400	480
Wiring		Δ	Δ	Y	Y
Frequency	Hz	50	60	50	60
Method of obtaining data		ml	ml	ml	ml
Valid for approval/standard		CE	CE	CE	CE
Speed (rpm)	min ⁻¹	905	1080	905	1080
Power consumption	W	1570	2180	1570	2180
Current draw	A	5.92	6.6	3.42	3.8
Max. back pressure	Pa	170	150	170	150
Max. back pressure	in. wg	0.68	0.6	0.68	0.6
Min. ambient temperature	°C	-40	-40	-40	-40
Max. ambient temperature	°C	65	60	65	60
Starting current	A	22	24	13	14

ml = Max. load · me = Max. efficiency · fa = Free air · cs = Customer specification · ce = Customer equipment
Subject to change

Data according to Commission Regulation (EU) 327/2011 (EN 17166)

		Actual	Req. 2015		
01 Overall efficiency η_{es}	%	35.4	34.6	09 Power consumption P_e	kW 1.38
02 Measurement category	A			09 Air flow q_v	m ³ /h 14570
03 Efficiency category	Static			09 Pressure increase p_{fs}	Pa 128
04 Efficiency grade N	40.8	40		10 Speed (rpm) n	min ⁻¹ 920
05 Variable speed drive	No			11 Specific ratio*	1.00

Data obtained at optimum efficiency level.
The ErP data is determined using a motor-impeller combination in a standardized measurement setup.

* Specific ratio = $1 + p_{fs} / 100\,000\text{ Pa}$

LU-114552



AC axial fan

sickle-shaped blades (S series)

with square full nozzle

Technical description

Weight	44.7 kg
Size	800 mm
Motor size	138
Rotor surface	Cast in aluminum
Terminal box material	PP plastic
Blade material	Sheet aluminum insert, sprayed with PP plastic
Fan housing material	Sheet steel, galvanized and coated with black plastic (RAL 9005)
Guard grille material	Steel, coated with black plastic (RAL 9005)
Number of blades	5
Blade pitch	-5°
Airflow direction	A
Direction of rotation	Counterclockwise, viewed toward rotor
Degree of protection	IP54
Insulation class	"F"
Moisture (F) / Environmental (H) protection class	H2
Ambient temperature note	Occasional start-up at temperatures between -40°C and -25°C is permitted. For continuous operation at ambient temperatures below -25°C (such as refrigeration applications), use must be made of a fan design with special low-temperature bearings.
Max. permitted ambient temp. for motor (transport/storage)	+80 °C
Min. permitted ambient temp. for motor (transport/storage)	-40 °C
Installation position	Any
Condensation drainage holes	On rotor and stator sides
Mode	S1
Motor bearing	Ball bearing
Touch current according to IEC 60990 (measuring circuit Fig. 4, TN system)	<= 3.5 mA
Electrical hookup	Terminal box
Motor protection	Thermal overload protector (TOP) with basic insulation
With cable	Axial
Protection class	I (with customer connection of protective earth)
Conformity with standards	EN 60034-1 (2010); CE
Approval	EAC; CSA C22.2 No. 100; UL 1004-1



AC axial fan

sickle-shaped blades (S series)
with square full nozzle

Product drawing

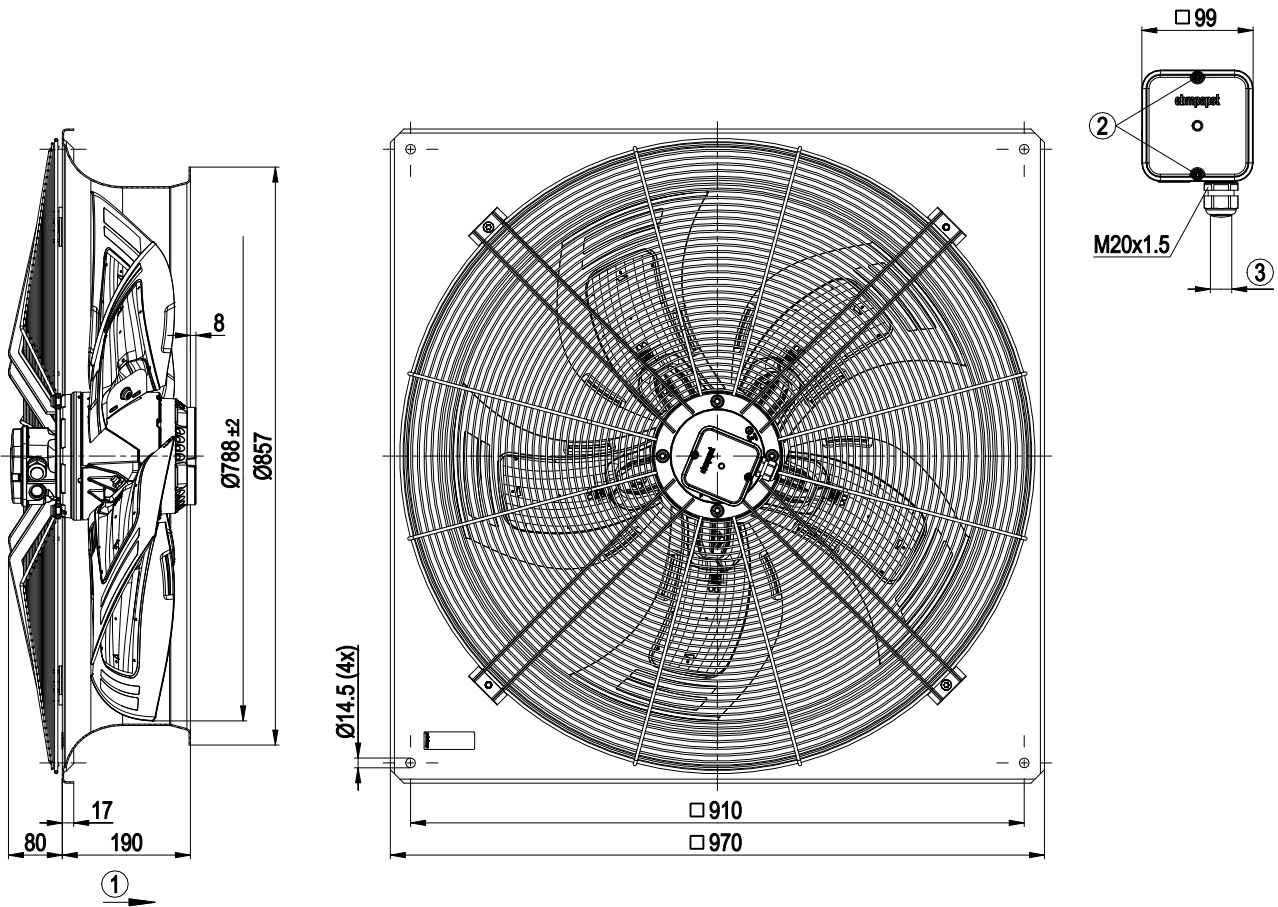

1	Direction of air flow "A"
2	Tightening torque 1.5 ± 0.2 Nm
3	Cable diameter min. 7 mm, max. 14 mm, tightening torque 2 ± 0.3 Nm



AC axial fan

sickle-shaped blades (S series)
with square full nozzle

Connection diagram

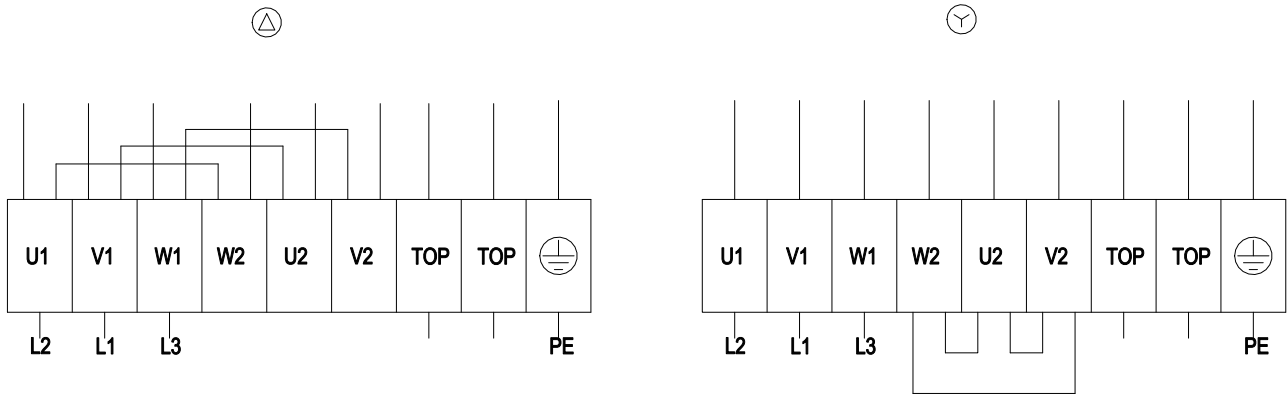

Δ	Delta connection	Y	Star connection	L1	= V1 = blue
L2	= U1 = black	L3	= W1 = brown	W2	yellow
U2	green	V2	white	TOP	2x gray
PE	green/yellow				



AC axial fan

sickle-shaped blades (S series)
with square full nozzle

Curves: Air performance 50 Hz

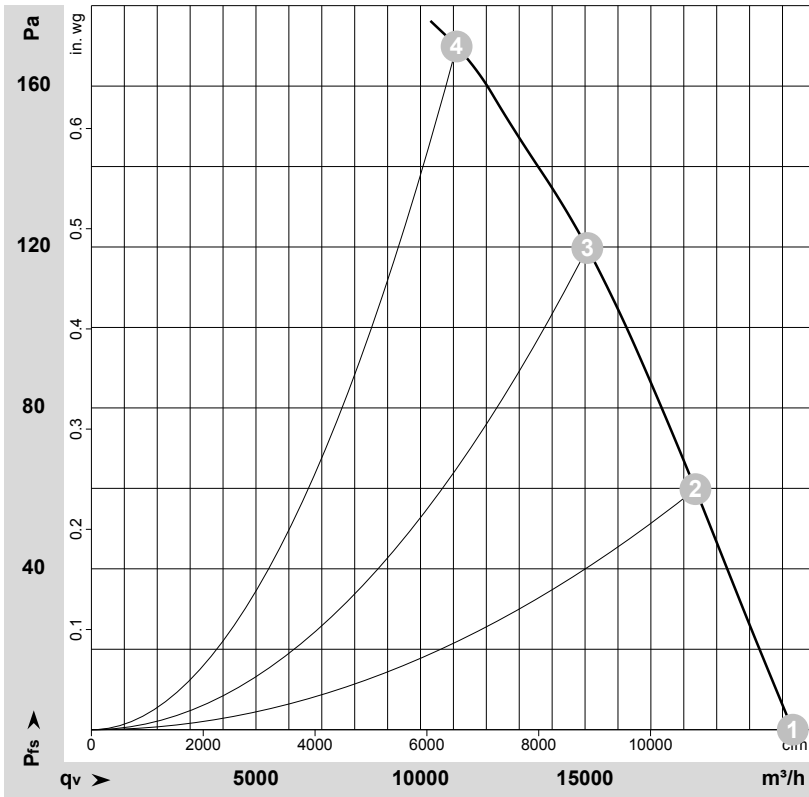

$\rho = 1.15 \text{ kg/m}^3 \pm 2 \%$

Measurement: LU-114552-1

Air performance measured according to ISO 5801 installation category A. For detailed information on the measurement setup, contact ebmpapst. Intake sound level: Sound power level according to ISO 13347 / sound pressure level measured at 1 m distance from fan axis. The values given are valid under the specified measuring conditions and may vary due to conditions of installation. For deviations from the standard configuration, the parameters have to be checked on the installed unit.

Measured values

	Wired	U	f	n	P_e	I	LpA_{in}	LwA_{in}	LwA_{out}	q_v	p_{fs}	q_v	p_{fs}
		V	Hz	min^{-1}	W	A	dB(A)	dB(A)	dB(A)	m^3/h	Pa	cfm	in. wg
1	Y	400	50	950	992	2.81	67	73	73	21310	0	12545	0.00
2	Y	400	50	935	1203	3.00	63	70	69	18355	60	10805	0.24
3	Y	400	50	920	1364	3.21	67	73	72	15070	120	8870	0.48
4	Y	400	50	905	1570	3.42	72	79	79	11095	170	6530	0.68

Wired = Wiring · U = Voltage · f = Frequency · n = Speed (rpm) · P_e = Power consumption · I = Current draw · LpA_{in} = Sound pressure level intake side · LwA_{in} = Sound power level intake side
 LwA_{out} = Sound power level outlet side · q_v = Air flow · p_{fs} = Pressure increase



AC axial fan

sickle-shaped blades (S series)
with square full nozzle

Curves: Air performance 60 Hz

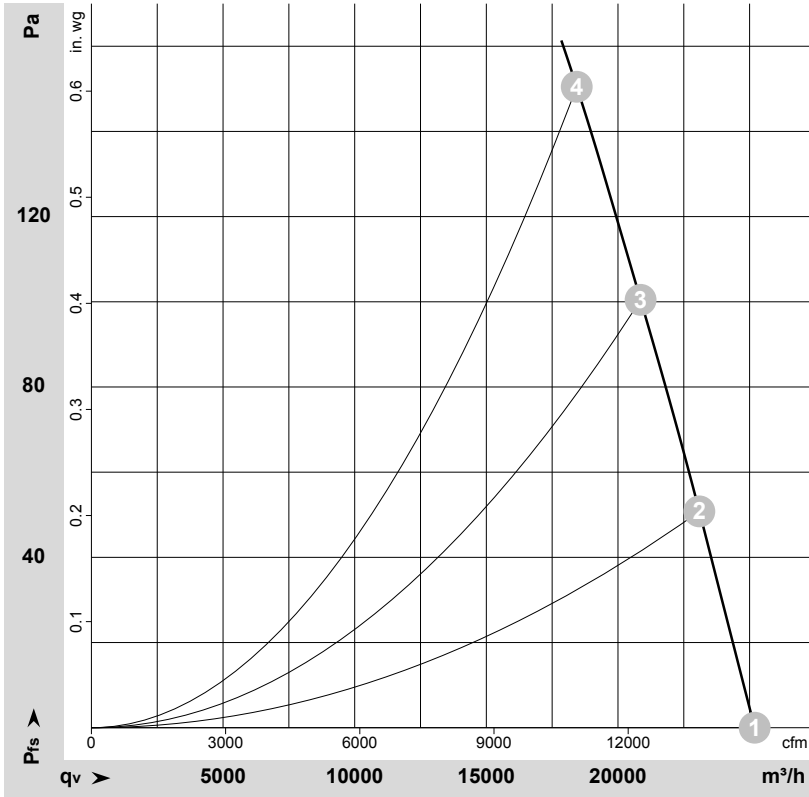

$\rho = 1.15 \text{ kg/m}^3 \pm 2 \%$

Measurement: LU-114632-1

Air performance measured according to ISO 5801 installation category A. For detailed information on the measurement setup, contact ebmpapst. Intake sound level: Sound power level according to ISO 13347 / sound pressure level measured at 1 m distance from fan axis. The values given are valid under the specified measuring conditions and may vary due to conditions of installation. For deviations from the standard configuration, the parameters have to be checked on the installed unit.

Measured values

	Wired	U	f	n	P _e	I	LpA _{in}	LwA _{in}	LwA _{out}	q _v	p _{fs}	q _v	p _{fs}
		V	Hz	min ⁻¹	W	A	dB(A)	dB(A)	dB(A)	m ³ /h	Pa	cfm	in. wg
1	Y	480	60	1125	1619	3.22	71	78	78	25190	0	14825	0.00
2	Y	480	60	1110	1826	3.45	68	75	75	23090	50	13590	0.20
3	Y	480	60	1095	2024	3.67	68	75	74	20860	100	12275	0.40
4	Y	480	60	1080	2180	3.80	70	77	75	18435	150	10850	0.60

Wired = Wiring · U = Voltage · f = Frequency · n = Speed (rpm) · P_e = Power consumption · I = Current draw · LpA_{in} = Sound pressure level intake side · LwA_{in} = Sound power level intake side
LwA_{out} = Sound power level outlet side · q_v = Air flow · p_{fs} = Pressure increase

