

# AC axial fan

sickle-shaped blades (S series)

with round full nozzle

W6D800-CJ01-85 ebmpapst Datasheet

sales@fansco.com

www.fansco.com

Limited partnership · Headquarters Muldingen

Amtsgericht (court of registration) Stuttgart · HRA 590344

General partner Elektrobau Muldingen GmbH · Headquarters Muldingen

Amtsgericht (court of registration) Stuttgart · HRB 590142



## Nominal data

Type	W6D800-CJ01-85		
Motor	M6D138-LA		
Phase		3~	3~
Nominal voltage	VAC	400	400
Wiring		Δ	Y
Frequency	Hz	50	50
Method of obtaining data		fa	fa
Valid for approval/standard		CE	CE
Speed	min <sup>-1</sup>	930	785
Power consumption	W	1440	1030
Current draw	A	3.5	1.9
Min. ambient temperature	°C	-40	-40
Max. ambient temperature	°C	60	60
Starting current	A	13	4.3

ml = Max. load · me = Max. efficiency · fa = Free air · cs = Customer specification · ce = Customer equipment  
Subject to change

## Data according to ErP Directive

		Actual	Req. 2015		
01 Overall efficiency $\eta_{es}$	%	35.4	35.2	09 Power consumption $P_e$	kW 1.76
02 Measurement category		A		09 Air flow $q_v$	m <sup>3</sup> /h 17035
03 Efficiency category		Static		09 Pressure increase $p_{fs}$	Pa 132
04 Efficiency grade N		40.2	40	10 Speed n	min <sup>-1</sup> 900
05 Variable speed drive		No		11 Specific ratio*	1.00

Data obtained at optimum efficiency level.

The ErP data is determined using a motor-impeller combination in a standardized measurement setup.

\* Specific ratio =  $1 + p_s / 100\,000\text{ Pa}$ 

LU-100640



# AC axial fan

sickle-shaped blades (S series)

with round full nozzle

## Technical description

<b>Weight</b>	51 kg
<b>Fan size</b>	800 mm
<b>Rotor surface</b>	Painted black
<b>Terminal box material</b>	Die-cast aluminum, painted black
<b>Blade material</b>	Die-cast aluminum, painted black
<b>Fan housing material</b>	Sheet steel, galvanized and coated with cement-gray plastic (RAL 7033)
<b>Guard grille material</b>	Steel, galvanized and coated with cement-gray plastic (RAL 7033)
<b>Number of blades</b>	5
<b>Blade pitch</b>	0°
<b>Airflow direction</b>	"A"
<b>Direction of rotation</b>	Counterclockwise, viewed toward rotor
<b>Degree of protection</b>	IP55
<b>Insulation class</b>	"F"
<b>Moisture (F) / Environmental (H) protection class</b>	F4-2
<b>Max. permitted ambient temp. for motor (transport/storage)</b>	+80 °C
<b>Min. permitted ambient temp. for motor (transport/storage)</b>	-40 °C
<b>Installation position</b>	Shaft horizontal or rotor on top; rotor on bottom on request
<b>Condensation drainage holes</b>	On stator side
<b>Mode</b>	S1
<b>Motor bearing</b>	Ball bearing
<b>Touch current according to IEC 60990 (measuring circuit Fig. 4, TN system)</b>	<= 3.5 mA
<b>Electrical hookup</b>	Via terminal box
<b>Motor protection</b>	Thermal overload protector (TOP) with basic insulation
<b>With cable</b>	Axial
<b>Protection class</b>	I (with customer connection of protective earth)
<b>Conformity with standards</b>	EN 60034-1 (2010); EN 61800-5-1; CE
<b>Approval</b>	EAC; VDE



W6D800-CJ01-85

# AC axial fan

sickle-shaped blades (S series)  
with round full nozzle

## Product drawing

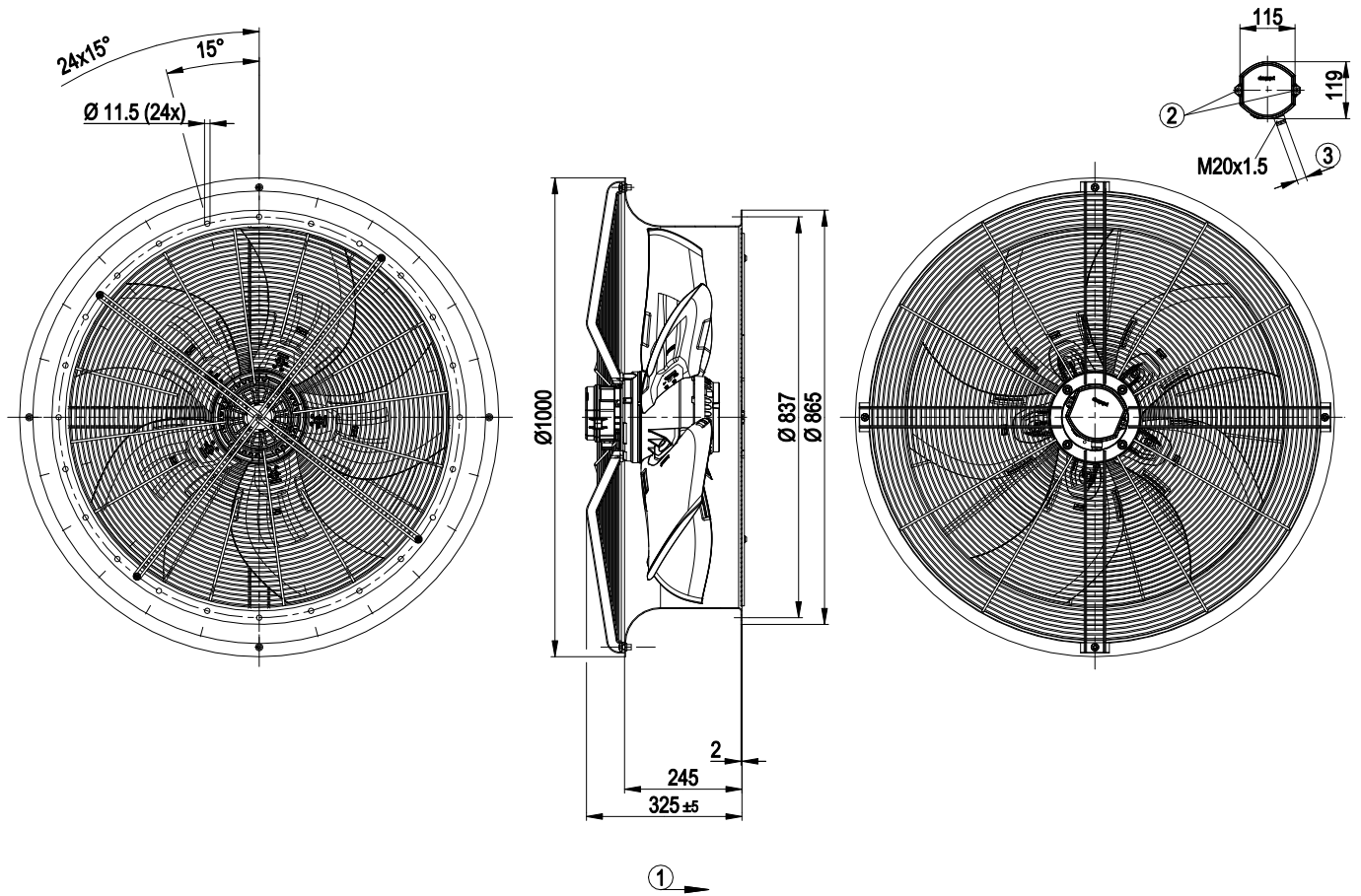

1	Direction of air flow "A"
2	Tightening torque $2.5 \pm 0.4$ Nm
3	Cable diameter min. 10 mm, max. 12 mm, tightening torque $4 \pm 0.4$ Nm



# AC axial fan

sickle-shaped blades (S series)  
with round full nozzle

## Connection diagram

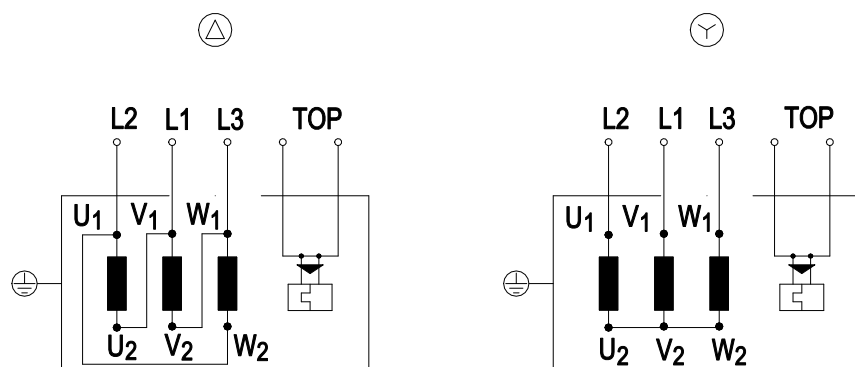

Change of rotation direction by reversing two phases

Δ	Delta connection	Y	Star connection	L2	= U1 = black
L1	= V1 = blue	L3	= W1 = brown	W2	yellow
U2	green	V2	white	TOP	2x gray
PE	green/yellow				

# AC axial fan

sickle-shaped blades (S series)  
with round full nozzle

## Curves: Air performance 50 Hz

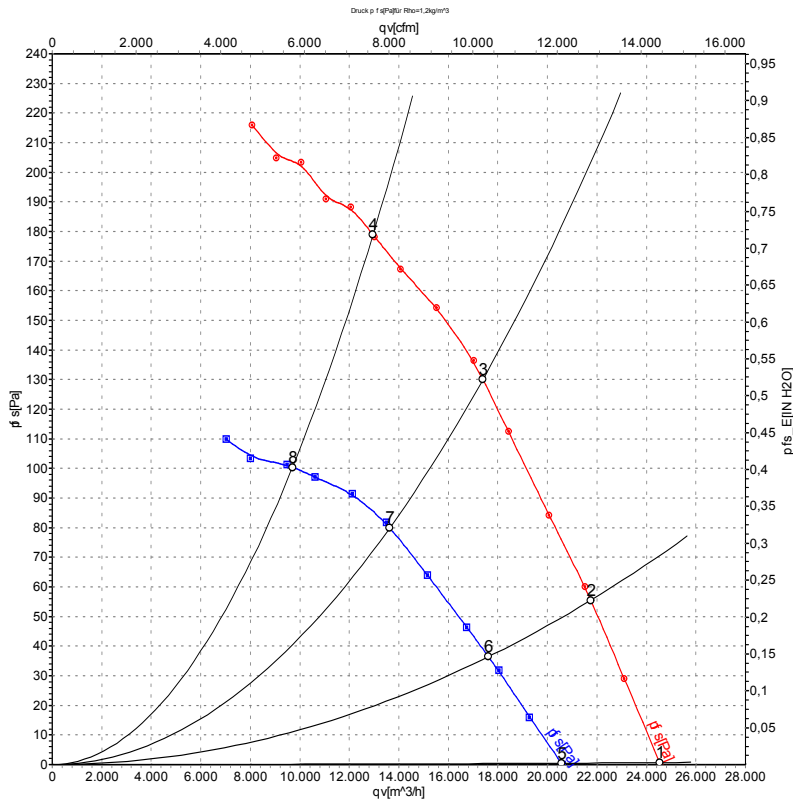

Measurement: LU-100640-1  
Measurement: LU-100800-1

Air performance measured according to ISO 5801 installation category A. For detailed information on the measurement setup, contact ebm-papst. Intake sound level: Sound power level according to ISO 13347 / sound pressure level measured at 1 m distance from fan axis. The values given are valid under the specified measuring conditions and may vary due to conditions of installation. For deviations from the standard configuration, the parameters have to be checked on the installed unit.

## Measured values

	Wired	U	f	n	P <sub>e</sub>	I	LpA <sub>in</sub>	LwA <sub>in</sub>	qv	P <sub>fs</sub>
		V	Hz	min <sup>-1</sup>	W	A	dB(A)	dB(A)	m <sup>3</sup> /h	Pa
1	Δ	400	50	930	1440	3.50	67	73	24530	0
2	Δ	400	50	915	1561	3.50	65	71	21750	55
3	Δ	400	50	900	1749	3.63	66	72	17390	130
4	Δ	400	50	895	2000	4.30	71	78	12960	180
5	Y	400	50	785	1030	1.90	63	70	20570	0
6	Y	400	50	750	1080	2.02	61	68	17620	36
7	Y	400	50	705	1157	2.17	61	67	13630	80
8	Y	400	50	685	1270	2.50	64	72	9705	100

Wired = Wiring · U = Power supply · f = Frequency · n = Speed · P<sub>e</sub> = Power consumption · I = Current draw · LpA<sub>in</sub> = Sound pressure level intake side · LwA<sub>in</sub> = Sound power level intake side  
qv = Air flow · P<sub>fs</sub> = Pressure increase

