

AC axial fan - HyBlade

sickle-shaped blades (S series)

with round full nozzle, Transformer fan

W6D800-CD01-84 ebmpapst Datasheet

sales@fansco.com

www.fansco.com

Limited partnership · Headquarters Muldingen

Amtsgericht (court of registration) Stuttgart · HRA 590344

General partner Elektrobau Muldingen GmbH · Headquarters Muldingen

Amtsgericht (court of registration) Stuttgart · HRB 590142

Nominal data

Type	W6D800-CD01-84		
Motor	M6D138-LA		
Phase		3~	3~
Nominal voltage	VAC	400	400
Wiring		Δ	Y
Frequency	Hz	50	50
Method of obtaining data		fa	fa
Valid for approval/standard		CE	CE
Speed (rpm)	min ⁻¹	925	780
Power consumption	W	1380	1000
Current draw	A	3.3	1.85
Max. back pressure	Pa	160	92
Max. back pressure	in. wg	0.64	0.37
Min. ambient temperature	°C	-40	-40
Max. ambient temperature	°C	60	60
Starting current	A	13	4.3

ml = Max. load · me = Max. efficiency · fa = Free air · cs = Customer specification · ce = Customer equipment
Subject to change

Data according to Commission Regulation (EU) 327/2011

		Actual	Req. 2015			
01 Overall efficiency η_{es}	%	35.2	35.2	09 Power consumption P_e	kW	1.72
02 Measurement category		A		09 Air flow q_v	m ³ /h	17215
03 Efficiency category		Static		09 Pressure increase p_{fs}	Pa	124
04 Efficiency grade N		40	40	10 Speed (rpm) n	min ⁻¹	905
05 Variable speed drive		No		11 Specific ratio*		1.00

Data obtained at optimum efficiency level.
The ErP data is determined using a motor-impeller combination in a standardized measurement setup.

* Specific ratio = $1 + p_s / 100\,000\text{ Pa}$

LU-122313



AC axial fan - HyBlade

sickle-shaped blades (S series)

with round full nozzle, Transformer fan

Technical description

Weight	45 kg
Size	800 mm
Motor size	138
Rotor surface	Painted black
Terminal box material	Die-cast aluminum, painted black
Blade material	Sheet aluminum insert (painted black), sprayed with PP plastic
Fan housing material	Sheet steel, galvanized and coated with white aluminum plastic (RAL 9006)
Guard grille material	Steel, coated with white-aluminum plastic (RAL 9006)
Number of blades	5
Blade pitch	0°
Airflow direction	A
Direction of rotation	Counterclockwise, viewed toward rotor
Degree of protection	IP55
Insulation class	"F"
Moisture (F) / Environmental (H) protection class	H2+T
Ambient temperature note	Occasional start-up at temperatures between -40°C and -25°C is permitted. For continuous operation at ambient temperatures below -25°C (such as refrigeration applications), use must be made of a fan design with special low-temperature bearings.
Max. permitted ambient temp. for motor (transport/storage)	+80 °C
Min. permitted ambient temp. for motor (transport/storage)	-40 °C
Installation position	Shaft horizontal or rotor on top; rotor on bottom on request
Condensation drainage holes	On stator side
Mode	S1
Motor bearing	Ball bearing
Touch current according to IEC 60990 (measuring circuit Fig. 4, TN system)	≤ 3.5 mA
Electrical hookup	Terminal box
Motor protection	Thermal overload protector (TOP) with basic insulation
Protection class	I (with customer connection of protective earth)
Conformity with standards	EN 60034-1 (2010); CE
Approval	VDE; EAC



AC axial fan - HyBlade

sickle-shaped blades (S series)

with round full nozzle, Transformer fan

Product drawing

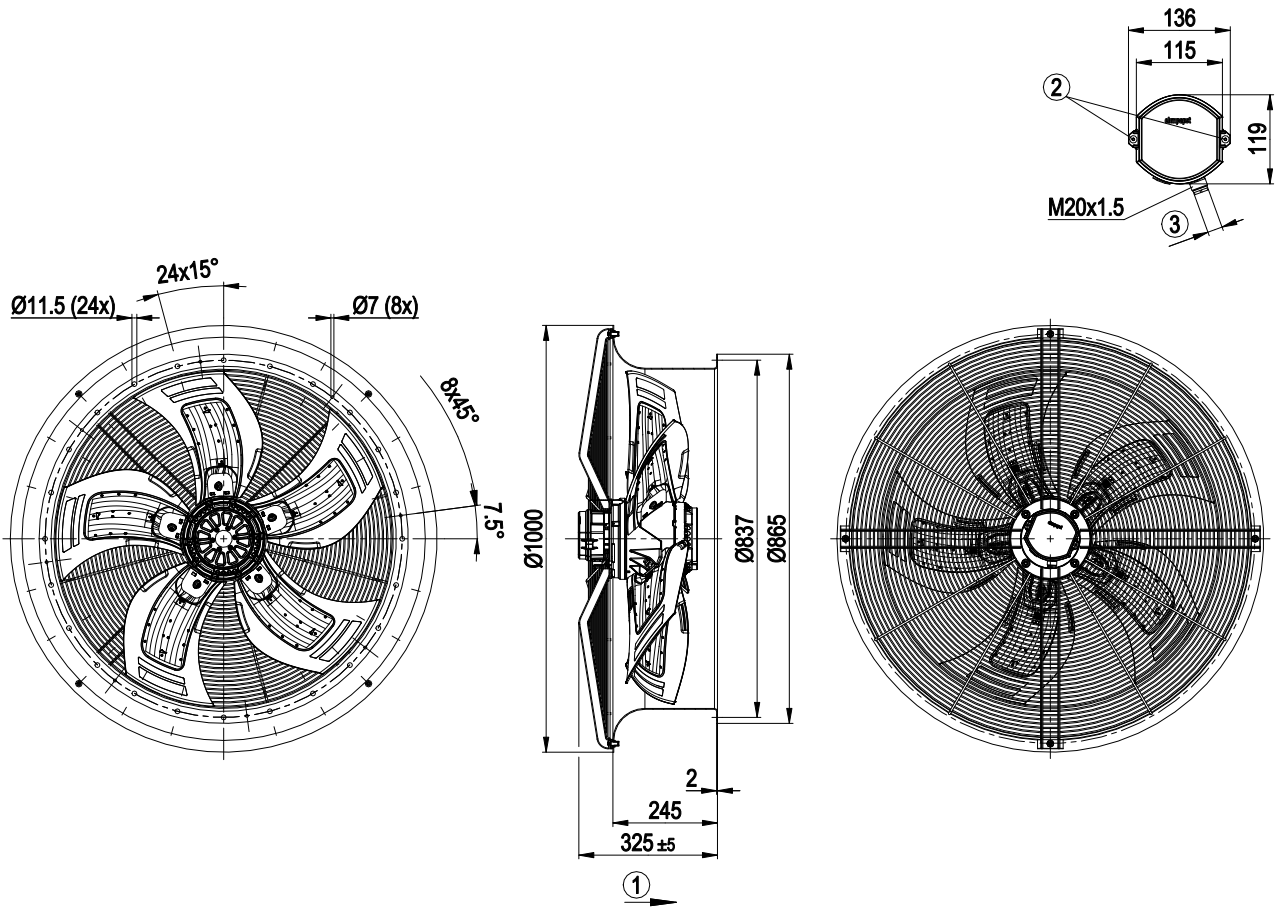

1	Direction of air flow "A"
2	Tightening torque 2.5 ± 0.4 Nm
3	Cable diameter min. 10 mm, max. 12 mm, tightening torque 4 ± 0.6 Nm



AC axial fan - HyBlade

sickle-shaped blades (S series)

with round full nozzle, Transformer fan

Connection diagram

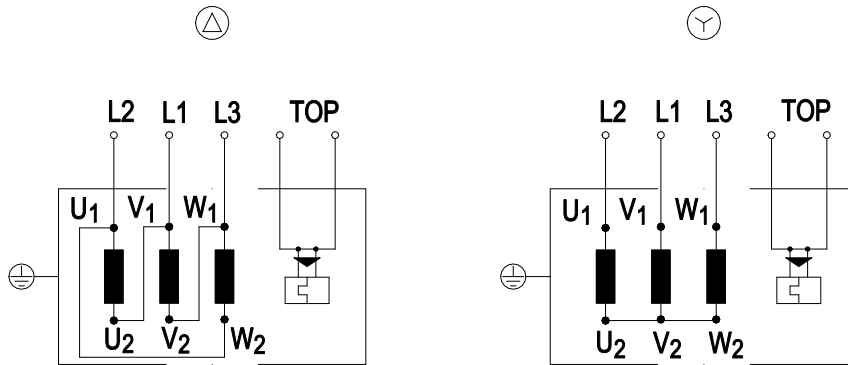

Change of rotation direction by reversing two phases

Δ	Delta connection	Y	Star connection	L2	= U1 = black
L1	= V1 = blue	L3	= W1 = brown	W2	yellow
U2	green	V2	white	TOP	2x gray
PE	green/yellow				



AC axial fan - HyBlade

sickle-shaped blades (S series)
with round full nozzle, Transformer fan

Curves: Air performance 50 Hz

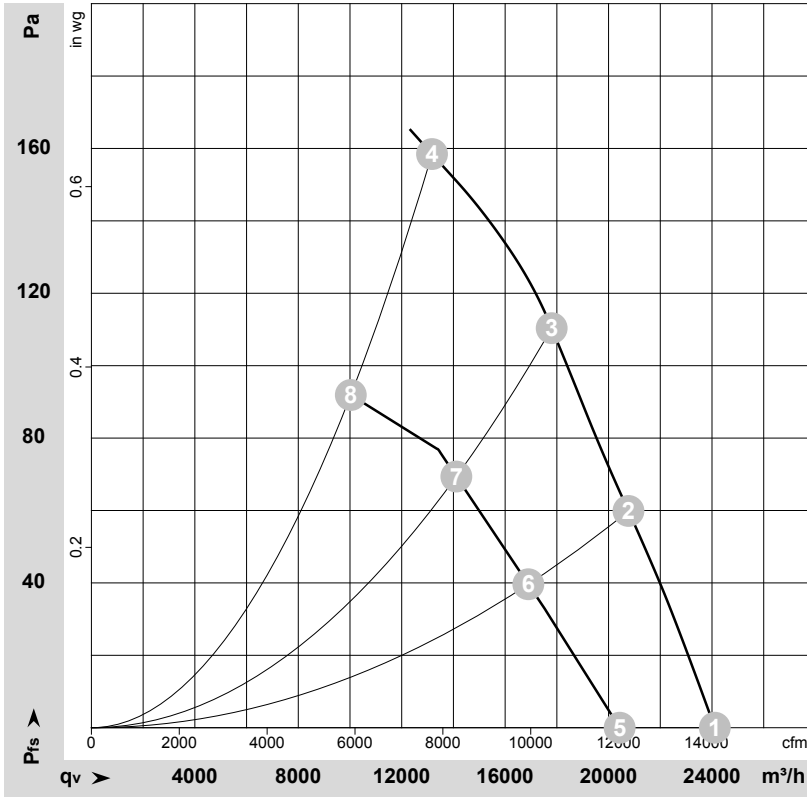

$\rho = 1.15 \text{ kg/m}^3 \pm 2 \%$

Measurement: LU-113998-1
Measurement: LU-115288-1

Air performance measured according to ISO 5801 installation category A. For detailed information on the measurement setup, contact ebm-papst. Intake sound level: Sound power level according to ISO 13347 / sound pressure level measured at 1 m distance from fan axis. The values given are valid under the specified measuring conditions and may vary due to conditions of installation. For deviations from the standard configuration, the parameters have to be checked on the installed unit.

Measured values

	Wired	U	f	n	P _e	I	LpA _{in}	LwA _{in}	LwA _{out}	q _v	p _{fs}	q _v	p _{fs}
		V	Hz	min ⁻¹	W	A	dB(A)	dB(A)	dB(A)	m ³ /h	Pa	cfm	in. wg
1	Δ	400	50	925	1380	3.30	65	72	72	24110	0	14190	0.00
2	Δ	400	50	910	1585	3.44	65	72	71	20770	60	12225	0.24
3	Δ	400	50	900	1725	3.61	67	73	72	17800	110	10475	0.44
4	Δ	400	50	880	1940	3.90	70	77	77	13170	160	7755	0.64
5	Y	400	50	780	1000	1.85	61	68	67	20430	0	12025	0.00
6	Y	400	50	735	1080	1.98	60	66	66	16895	40	9945	0.16
7	Y	400	50	710	1133	2.08	60	67	66	14115	69	8305	0.28
8	Y	400	50	670	1210	2.23	63	70	69	10030	92	5905	0.37

Wired = Wiring · U = Voltage · f = Frequency · n = Speed (rpm) · P_e = Power consumption · I = Current draw · LpA_{in} = Sound pressure level intake side · LwA_{in} = Sound power level intake side
LwA_{out} = Sound power level outlet side · q_v = Air flow · p_{fs} = Pressure increase

