

W6D710-GH03-03 ebmpapst Datasheet

sales@fansco.com

www.fansco.com

Limited partnership · Headquarters Muldingen  
County court Stuttgart · HRA 590344General partner Elektrobau Muldingen GmbH · Headquarters Muldingen  
County court Stuttgart · HRB 590142

## Nominal data

Type	W6D710-GH03-03				
Motor	M6D138-HF				
Phase		3~	3~	3~	3~
Nominal voltage	VAC	230	230	400	400
Connection		Δ	Δ	Y	Y
Frequency	Hz	50	60	50	60
Type of data definition		ml	ml	ml	ml
Valid for approval / standard		CE	CE	CE	CE
Speed	min <sup>-1</sup>	910	995	910	995
Power input	W	990	1470	990	1470
Current draw	A	3.98	4.92	2.3	2.84
Max. back pressure	Pa	115	140	115	140
Min. ambient temperature	°C	-40	-40	-40	-40
Max. ambient temperature	°C	70	65	70	65
Starting current	A	15	13	9.0	7.5

ml = Max. load · me = Max. efficiency · fa = Running at free air · cs = Customer specs · cu = Customer unit  
Subject to alterations

## Data according to ErP directive

Installation category	A
Efficiency category	Static
Variable speed drive	No
Specific ratio*	1.00

\* Specific ratio =  $1 + p_{fs} / 100\,000\text{ Pa}$ 

		Actual	Request 2013	Request 2015
Overall efficiency $\eta_{es}$	%	33.9	29.5	33.5
Efficiency grade N		40.4	36	40
Power input $P_e$	kW	0.95		
Air flow $q_v$	m <sup>3</sup> /h	11220		
Pressure increase $p_{fs}$	Pa	105		
Speed n	min <sup>-1</sup>	910		

Data definition with optimum efficiency. LU-121549  
The ErP data is determined using a motor-impeller combination in a standardised measurement configuration.

## Technical features

Mass	37.2 kg
Size	710 mm
Surface of rotor	Cast in aluminium
Material of terminal box	PC / ABS plastic
Material of blades	Aluminium sheet insert, sprayed with PP plastic
Material of wall ring	Sheet steel, galvanised and coated in black plastic (RAL 9005)
Material of guard grille	Steel, coated in black plastic (RAL9005)
Number of blades	5
Blade angle	-5°
Direction of air flow	"V"
Direction of rotation	Clockwise, seen on rotor
Type of protection	IP 54
Insulation class	"F"
Humidity class	F3-1
Max. permissible ambient motor temp. (transp./ storage)	+ 80 °C
Min. permissible ambient motor temp. (transp./storage)	- 40 °C
Mounting position	Any
Condensate discharge holes	On rotor and stator sides
Operation mode	S1
Motor bearing	Ball bearing
Touch current acc. IEC 60990 (measuring network Fig. 4, TN system)	<= 3.5 mA
Electrical leads	Via terminal box
Motor protection	Thermal overload protector (TOP) brought out
Cable exit	Axial
Protection class	I (if protective earth is connected by customer)
Product conforming to standard	EN 61800-5-1; EN 60034; CE
Approval	CSA C22.2 Nr.100; EAC; UL 1004-1

# AC axial fan - HyBlade®

sickled blades (S series)

with full square nozzle

## Product drawing

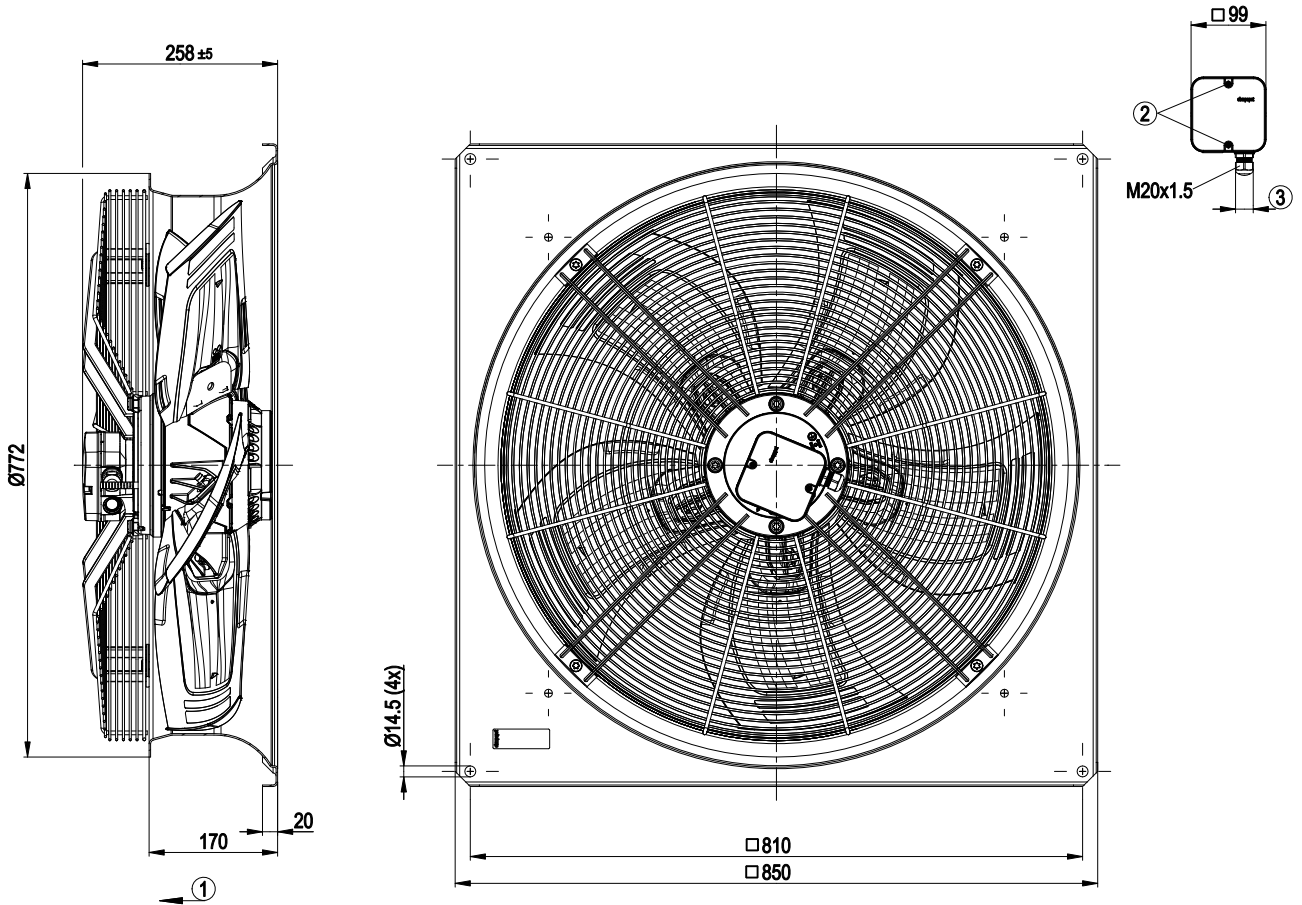

1	Direction of air flow "V"
2	Tightening torque $1.5 \pm 0.2$ Nm
4	Cable diameter: min. 7 mm, max. 14 mm; tightening torque $2.0 \pm 0.3$ Nm



# AC axial fan - HyBlade®

sickled blades (S series)

with full square nozzle

## Connection screen

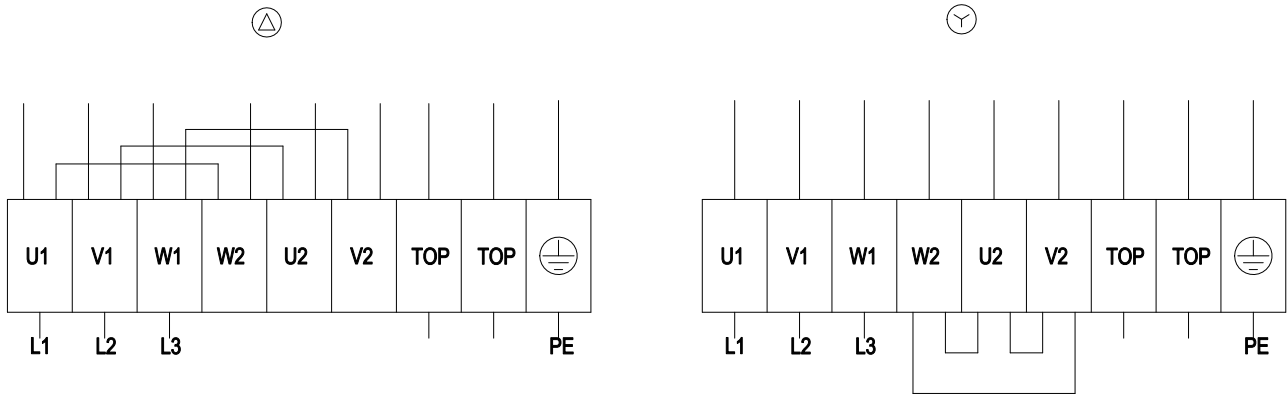

Δ	Delta connection	Y	Star connection	L1	= U1 = black
L2	= V1 = blue	L3	= W1 = brown	W2	yellow
U2	green	V2	white	TOP	2 x grey
PE	green/yellow				



## Charts: Air flow 50 Hz

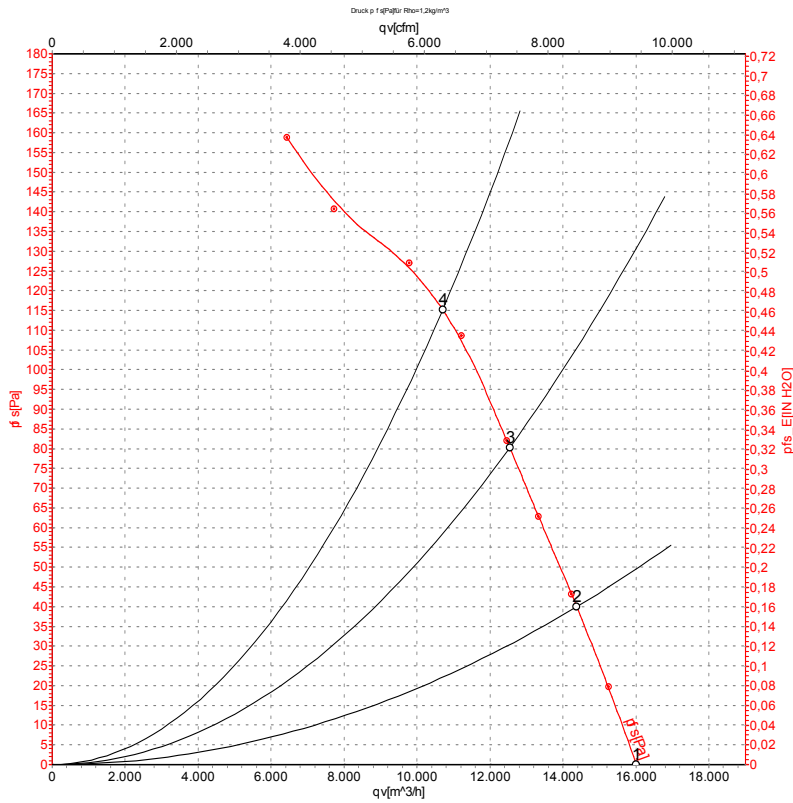

Air performance measured as per ISO 5801 Installation category A. For detailed information on the measuring set-up, please contact ebm-papst. Suction-side noise levels: LwA measured as per ISO 13347 / LpA measured with 1m distance to fan axis. The values given are valid under the measuring conditions mentioned above and may vary according to the actual installation situation. With any deviation from the standard set-up, the specific values have to be checked and reviewed with the unit installed.

## Measured values

	Conn.	U	f	n	P <sub>e</sub>	I	LpA <sub>in</sub>	LwA <sub>in</sub>	LwA <sub>out</sub>	qv	p <sub>fs</sub>
		V	Hz	min <sup>-1</sup>	W	A	dB(A)	dB(A)	dB(A)	m <sup>3</sup> /h	Pa
1	Y	400	50	940	722	2.02	63	70	70	16010	0
2	Y	400	50	925	819	2.12	62	69	69	14370	40
3	Y	400	50	915	914	2.22	62	69	68	12540	80
4	Y	400	50	910	990	2.30	66	72	71	10700	115

Conn. = Connection · U = Supply voltage · f = Frequency · n = Speed · P<sub>e</sub> = Power input · I = Current draw · LpA<sub>in</sub> = Sound pressure level inlet side · LwA<sub>in</sub> = Sound power level inlet side  
 LwA<sub>out</sub> = Sound power level outlet side · qv = Air flow · p<sub>fs</sub> = Pressure increase



## Charts: Air flow 60 Hz

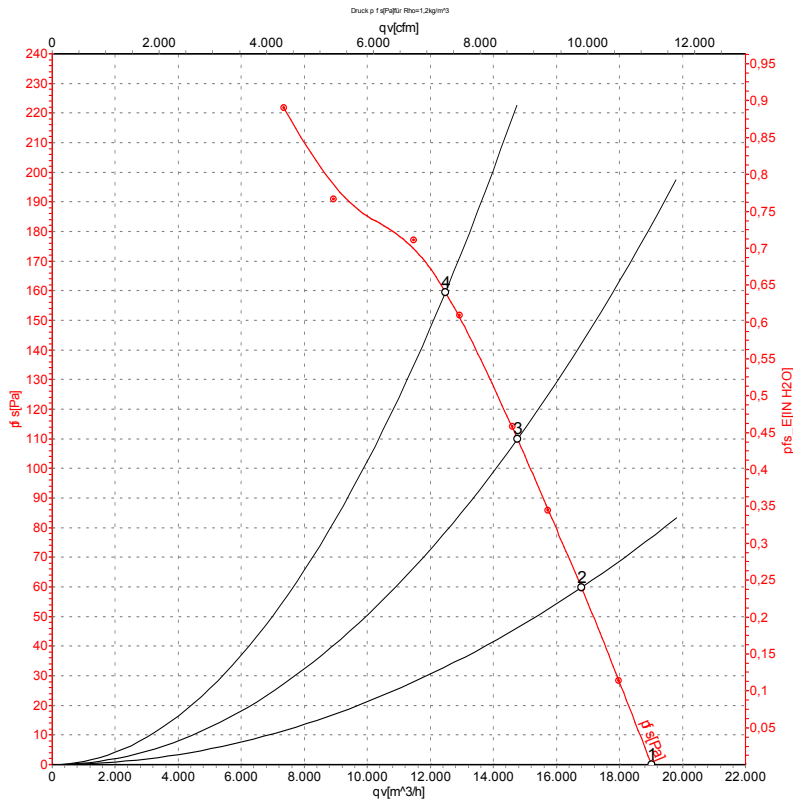

Air performance measured as per ISO 5801 Installation category A. For detailed information on the measuring set-up, please contact ebm-papst. Suction-side noise levels: LwA measured as per ISO 13347 / LpA measured with 1m distance to fan axis. The values given are valid under the measuring conditions mentioned above and may vary according to the actual installation situation. With any deviation from the standard set-up, the specific values have to be checked and reviewed with the unit installed.

## Measured values

	Conn.	U	f	n	Pe	I	LpA <sub>in</sub>	LwA <sub>in</sub>	LwA <sub>out</sub>	qv	p <sub>fs</sub>
		V	Hz	min <sup>-1</sup>	W	A	dB(A)	dB(A)	dB(A)	m <sup>3</sup> /h	Pa
1	Y	480	60	1105	1172	2.30	67	74	74	19020	0
2	Y	480	60	1090	1345	2.48	66	73	73	16800	60
3	Y	480	60	1075	1476	2.63	66	73	73	14770	110
4	Y	480	60	1060	1620	2.85	70	77	76	12480	160

Conn. = Connection · U = Supply voltage · f = Frequency · n = Speed · P<sub>e</sub> = Power input · I = Current draw · LpA<sub>in</sub> = Sound pressure level inlet side · LwA<sub>in</sub> = Sound power level inlet side  
 LwA<sub>out</sub> = Sound power level outlet side · qv = Air flow · p<sub>fs</sub> = Pressure increase

