

W6D630-NT01-01 ebmpapst Datasheet

sales@fansco.com

www.fansco.com

Limited partnership · Headquarters Mulfingen

Amtsgericht (court of registration) Stuttgart · HRA 590344

General partner Elektrobau Mulfingen GmbH · Headquarters Mulfingen

Amtsgericht (court of registration) Stuttgart · HRB 590142

Nominal data

Type	W6D630-NT01-01		
Motor	M6D110-GF		
Phase		3~	3~
Nominal voltage	VAC	400	400
Wiring		Δ	Y
Frequency	Hz	50	50
Method of obtaining data		ml	ml
Valid for approval/standard		CE	CE
Speed (rpm)	min ⁻¹	890	680
Power consumption	W	545	360
Current draw	A	1.2	0.65
Max. back pressure	Pa	115	68
Max. back pressure	in. wg	0.46	0.27
Min. ambient temperature	°C	-40	-40
Max. ambient temperature	°C	60	60
Starting current	A	3.8	1.3

ml = Max. load · me = Max. efficiency · fa = Free air · cs = Customer specification · ce = Customer equipment
Subject to change

Data according to Commission Regulation (EU) 327/2011 (EN 17166)

		Actual	Req. 2015			
01 Overall efficiency η_{es}	%	39.3	31.8	09 Power consumption P_e	kW	0.51
02 Measurement category		A		09 Air flow q_v	m ³ /h	7340
03 Efficiency category		Static		09 Pressure increase p_{fs}	Pa	102
04 Efficiency grade N		47.5	40	10 Speed (rpm) n	min ⁻¹	900
05 Variable speed drive		No		11 Specific ratio*		1.00

Data obtained at optimum efficiency level.
The ErP data is determined using a motor-impeller combination in a standardized measurement setup.

* Specific ratio = $1 + p_{fs} / 100\,000\text{ Pa}$

LU-199199



AC axial fan - AxiBlade

sickle-shaped blades (S series)

Fan housing with guard grille

Technical description

Weight	24.3 kg
Size	630 mm
Motor size	110
Rotor surface	Painted black
Terminal box material	PP plastic
Impeller material	PP plastic
Fan housing material	Sheet steel, galvanized and coated with black plastic (RAL 9005)
Guard grille material	Steel, coated with black plastic (RAL 9005)
Number of blades	5
Airflow direction	V
Direction of rotation	Clockwise, viewed toward rotor
Degree of protection	IP54
Insulation class	"F"
Moisture (F) / Environmental (H) protection class	H2
Ambient temperature note	Occasional start-up at temperatures between -40°C and -25°C is permitted. For continuous operation at ambient temperatures below -25°C (such as refrigeration applications), use must be made of a fan design with special low-temperature bearings.
Max. permitted ambient temp. for motor (transport/storage)	+80 °C
Min. permitted ambient temp. for motor (transport/storage)	-40 °C
Installation position	Shaft horizontal or rotor on bottom; rotor on top on request
Condensation drainage holes	On rotor side
Mode	S1
Motor bearing	Ball bearing
Touch current according to IEC 60990 (measuring circuit Fig. 4, TN system)	<= 3.5 mA
Electrical hookup	Terminal box
Motor protection	Thermal overload protector (TOP) with basic insulation
Protection class	I (with customer connection of protective earth)
Conformity with standards	EN 61800-5-1; CE
Approval	EAC; VDE



AC axial fan - AxiBlade

sickle-shaped blades (S series)

Fan housing with guard grille

Product drawing

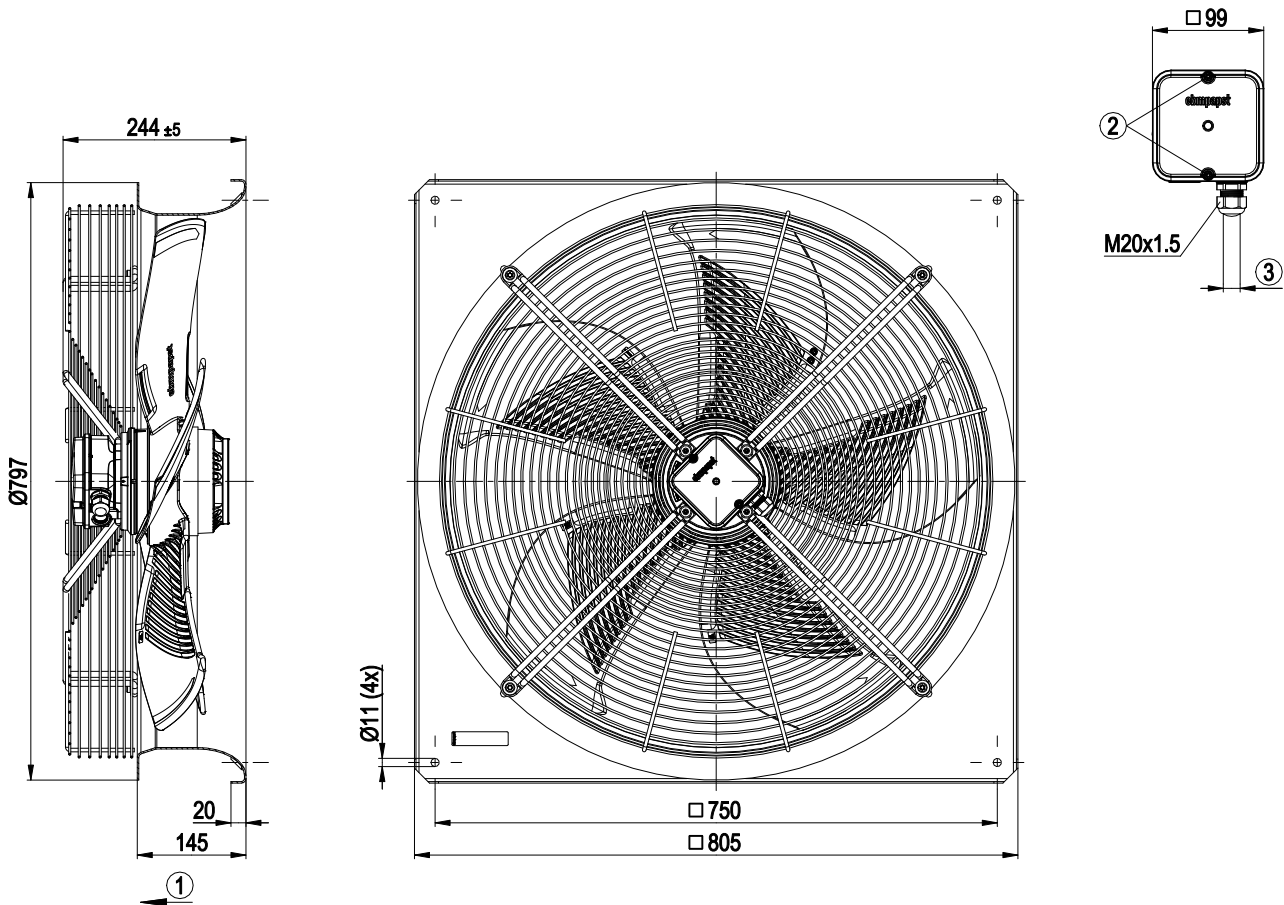

1	Airflow direction "V"
2	Tightening torque 1.5 ± 0.2 Nm
3	Cable diameter min. 6 mm, max. 12 mm, tightening torque 2 ± 0.3 Nm



AC axial fan - AxiBlade

sickle-shaped blades (S series)

Fan housing with guard grille

Connection diagram

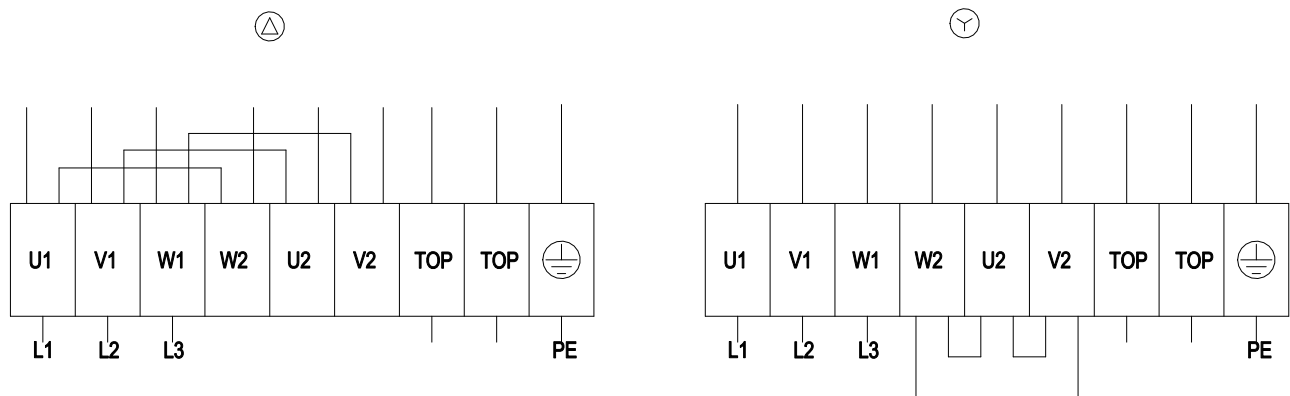

Δ	Delta connection	Y	Star connection	L1	= U1 = black
L2	= V1 = blue	L3	= W1 = brown	W2	yellow
U2	green	V2	white	TOP	2x gray
PE	green/yellow				



AC axial fan - AxiBlade

sickle-shaped blades (S series)

Fan housing with guard grille

Curves: Air performance 50 Hz

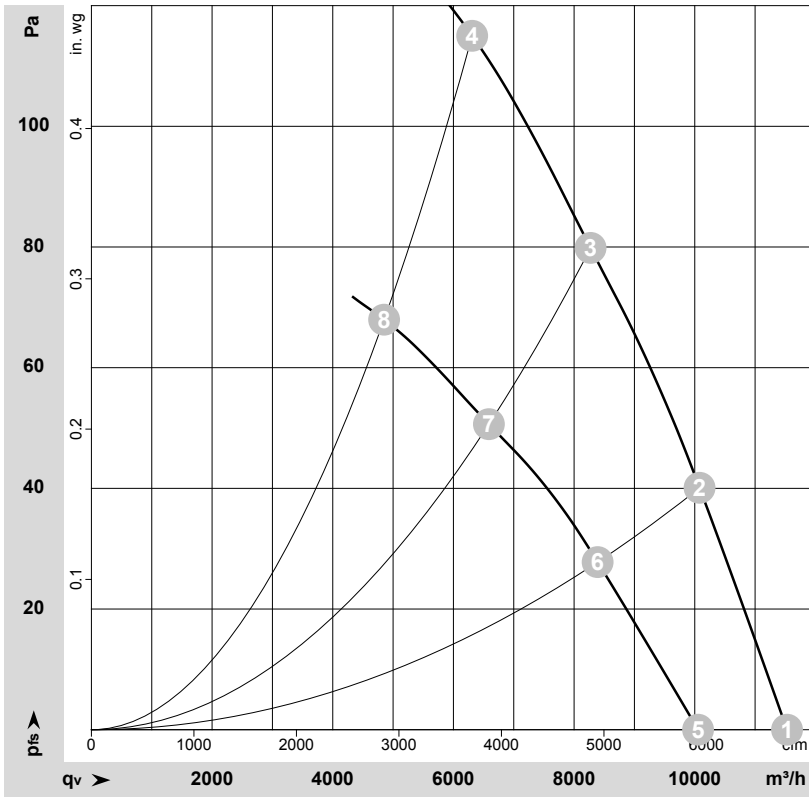

$\rho = 1.15 \text{ kg/m}^3 \pm 2 \%$

Measurement: LU-199200-1
Measurement: LU-199538-1

Air performance measured according to ISO 5801 installation category A. For detailed information on the measurement setup, contact ebm-papst. Intake sound level: Sound power level according to ISO 13347 / sound pressure level measured at 1 m distance from fan axis. The values given are valid under the specified measuring conditions and may vary due to conditions of installation. For deviations from the standard configuration, the parameters have to be checked on the installed unit.

Measured values

	Wired	U	f	n	P _e	I	LpA _{in}	LwA _{in}	LwA _{out}	q _v	p _{fs}	q _v	p _{fs}
		V	Hz	min ⁻¹	W	A	dB(A)	dB(A)	dB(A)	m ³ /h	Pa	cfm	in. wg
1	Δ	400	50	940	355	0.97	67	73	74	11530	0	6785	0.00
2	Δ	400	50	920	431	1.04	63	69	70	10080	40	5935	0.16
3	Δ	400	50	905	494	1.10	61	68	68	8275	80	4870	0.32
4	Δ	400	50	890	545	1.20	65	73	73	6310	115	3715	0.46
5	Y	400	50	815	261	0.49	64	70	70	10055	0	5920	0.00
6	Y	400	50	765	305	0.56	59	65	65	8390	28	4940	0.11
7	Y	400	50	715	338	0.61	56	62	62	6590	51	3880	0.20
8	Y	400	50	680	360	0.65	58	65	66	4850	68	2855	0.27

Wired = Wiring · U = Voltage · f = Frequency · n = Speed (rpm) · P_e = Power consumption · I = Current draw · LpA_{in} = Sound pressure level intake side · LwA_{in} = Sound power level intake side
LwA_{out} = Sound power level outlet side · q_v = Air flow · p_{fs} = Pressure increase

