

AC axial fan - HyBlade

sickle-shaped blades (S series)

with square full nozzle

ebm-papst Ventilator (Shanghai) Co.,Ltd.

No.418, Hua Jing Road, Wai Gao Qiao Free Trade Zone, Pudong

83

W6D630-GN01-01/F05 ebmpapst Datasheet

sales@fansco.com

www.fansco.com

Nominal data

Type	W6D630-GN01-01/F05						
Motor	M6D110-GF						
Phase		3~	3~	3~	3~	3~	3~
Nominal voltage	VAC	400	400	400	400	480	480
Wiring		Δ	Y	Δ	Y	Δ	Y
Frequency	Hz	50	50	60	60	60	60
Method of obtaining data		ml	ml	ml	ml	ml	ml
Valid for approval/standard		CE	CE	CE	CE	CE	CE
Speed (rpm)	min ⁻¹	890	690	1010	700	1070	820
Power consumption	W	600	400	730	430	810	550
Current draw	A	1.2	0.68	1.29	0.8	1.35	0.8
Max. back pressure	Pa	105	56	50	26	55	35
Max. back pressure	in. wg	0.42	0.22	0.2	0.1	0.22	0.14
Min. ambient temperature	°C	-40	-40	-40	-40	-40	-40
Max. ambient temperature	°C	65	65	60	60	55	55
Starting current	A	4		3.5			

ml = Max. load · me = Max. efficiency · fa = Free air · cs = Customer specification · ce = Customer equipment
Subject to change

Data according to Commission Regulation (EU) 327/2011

	Actual	Req. 2015				
01 Overall efficiency η_{es}	%	32.3	32.3	09 Power consumption P_e	kW	0.6
02 Measurement category		A		09 Air flow q_v	m ³ /h	7515
03 Efficiency category		Static		09 Pressure increase p_{fs}	Pa	92
04 Efficiency grade N		40	40	10 Speed (rpm) n	min ⁻¹	890
05 Variable speed drive		No		11 Specific ratio*		1.00

Data obtained at optimum efficiency level.
The ErP data is determined using a motor-impeller combination in a standardized measurement setup.

* Specific ratio = $1 + p_{fs} / 100\,000\text{ Pa}$

LU-105365



AC axial fan - HyBlade

sickle-shaped blades (S series)

with square full nozzle

Technical description

Weight	23.8 kg
Size	630 mm
Motor size	110
Rotor surface	Painted black
Terminal box material	PP plastic
Blade material	Press-fitted sheet steel blank, sprayed with PP plastic
Fan housing material	Sheet steel, galvanized and coated with light grey(RAL7035)
Guard grille material	Steel, coated with black plastic (RAL 9005)
Number of blades	5
Airflow direction	V
Direction of rotation	Counterclockwise, viewed toward rotor
Degree of protection	IP54
Insulation class	"F"
Moisture (F) / Environmental (H) protection class	H2
Ambient temperature note	Occasional start-up at temperatures between -40°C and -25°C is permitted. For continuous operation at ambient temperatures below -25°C (such as refrigeration applications), use must be made of a fan design with special low-temperature bearings.
Max. permitted ambient temp. for motor (transport/storage)	+80 °C
Min. permitted ambient temp. for motor (transport/storage)	-40 °C
Installation position	Shaft horizontal or rotor on bottom; rotor on top on request
Condensation drainage holes	On rotor side
Mode	S1
Motor bearing	Ball bearing
Touch current according to IEC 60990 (measuring circuit Fig. 4, TN system)	<= 3.5 mA
Electrical hookup	Terminal box
Motor protection	Thermal overload protector (TOP) with basic insulation
With cable	Axial
Protection class	I (with customer connection of protective earth)
Conformity with standards	EN 60034-1 (2010); CE
Approval	VDE; CCC; EAC



AC axial fan - HyBlade

sickle-shaped blades (S series)

with square full nozzle

Product drawing

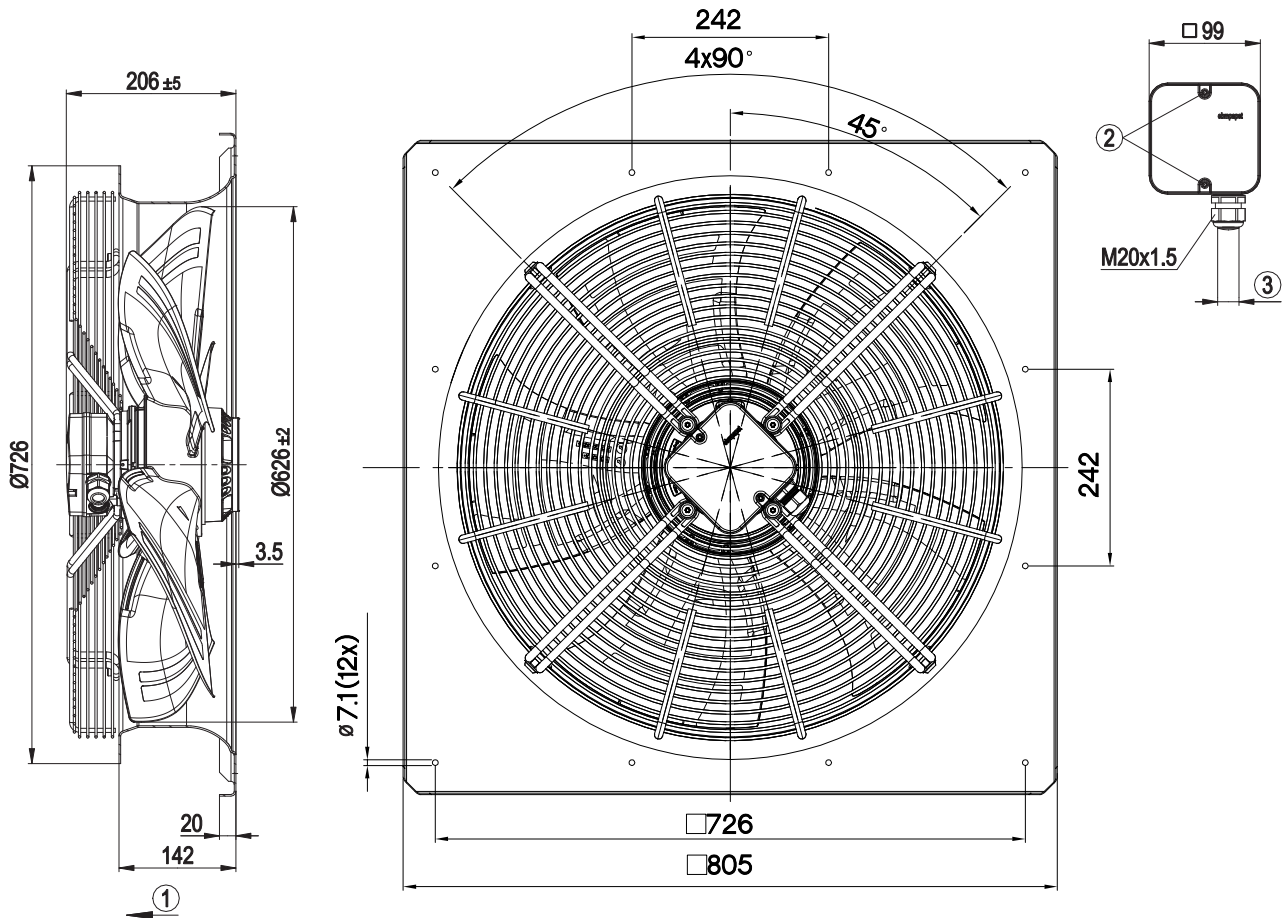

1	Direction of air flow "V"
2	Tightening torque 1.5 ± 0.2 Nm
3	Cable diameter min. 6 mm, max. 12 mm, tightening torque 2 ± 0.3 Nm



AC axial fan - HyBlade

sickle-shaped blades (S series)

with square full nozzle

Connection diagram

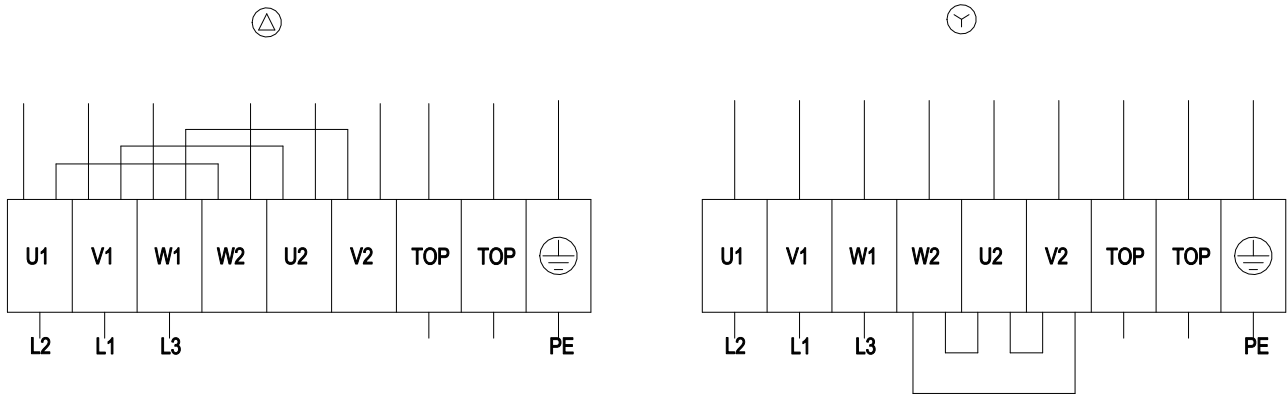

Δ	Delta connection	Y	Star connection	L1	= V1 = blue
L2	= U1 = black	L3	= W1 = brown	W2	yellow
U2	green	V2	white	TOP	2x gray
PE	green/yellow				



AC axial fan - HyBlade

sickle-shaped blades (S series)

with square full nozzle

Curves: Air performance 50 Hz

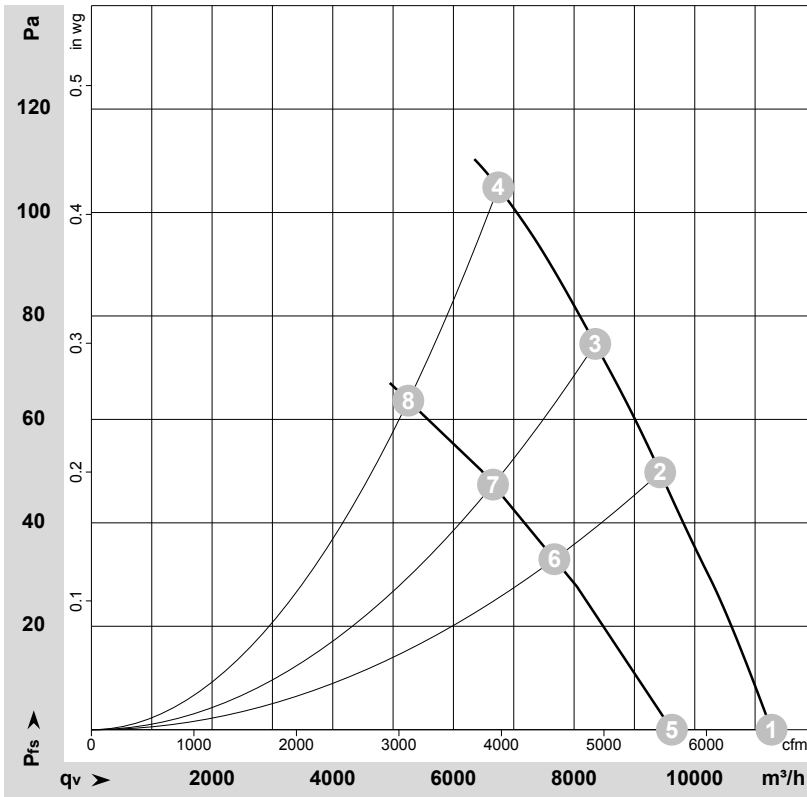

$\rho = 1.15 \text{ kg/m}^3 \pm 2 \%$

Measurement: LU-105365-1
Measurement: LU-107570-1

Air performance measured according to ISO 5801 installation category A. For detailed information on the measurement setup, contact ebm-papst. Intake sound level: Sound power level according to ISO 13347 / sound pressure level measured at 1 m distance from fan axis. The values given are valid under the specified measuring conditions and may vary due to conditions of installation. For deviations from the standard configuration, the parameters have to be checked on the installed unit.

Measured values

	Wired	U	f	n	P _e	I	LpA _{in}	LwA _{in}	LwA _{out}	q _v	p _{fs}	q _v	p _{fs}
		V	Hz	min ⁻¹	W	A	dB(A)	dB(A)	dB(A)	m ³ /h	Pa	cfm	in. wg
1	Δ	400	50	930	439	1.07	64	70	69	11270	0	6635	0.00
2	Δ	400	50	905	532	1.15	59	66	65	9425	50	5550	0.20
3	Δ	400	50	895	574	1.19	59	65	64	8350	75	4915	0.30
4	Δ	400	50	890	600	1.20	61	68	67	6745	105	3970	0.42
5	Y	400	50	790	319	0.56	59	65	65	9620	0	5665	0.00
6	Y	400	50	730	365	0.63	55	61	60	7675	33	4515	0.13
7	Y	400	50	705	385	0.66	53	60	59	6655	47	3920	0.19
8	Y	400	50	690	400	0.68	55	62	62	5255	64	3090	0.26

Wired = Wiring · U = Voltage · f = Frequency · n = Speed (rpm) · P_e = Power consumption · I = Current draw · LpA_{in} = Sound pressure level intake side · LwA_{in} = Sound power level intake side
LwA_{out} = Sound power level outlet side · q_v = Air flow · p_{fs} = Pressure increase



AC axial fan - HyBlade

sickle-shaped blades (S series)

with square full nozzle

Curves: Air performance 60 Hz

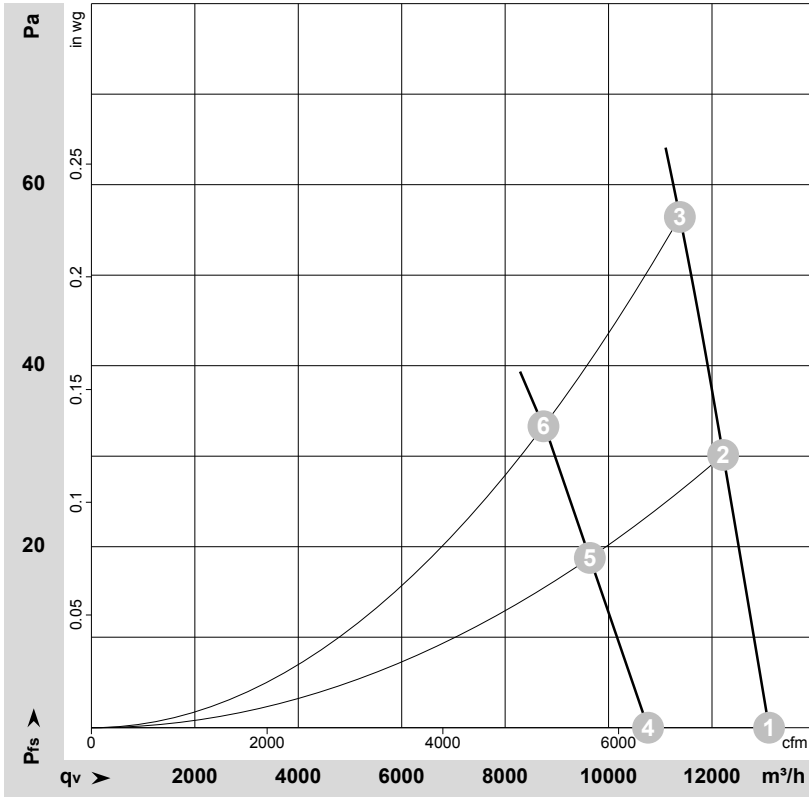

$\rho = 1.175 \text{ kg/m}^3 \pm 2 \%$

Measurement: LU-105784-1
Measurement: LU-114171-1

Air performance measured according to ISO 5801 installation category A. For detailed information on the measurement setup, contact ebm-papst. Intake sound level: Sound power level according to ISO 13347 / sound pressure level measured at 1 m distance from fan axis. The values given are valid under the specified measuring conditions and may vary due to conditions of installation. For deviations from the standard configuration, the parameters have to be checked on the installed unit.

Measured values

	Wired	U	f	n	P _e	I	LpA _{in}	LwA _{in}	LwA _{out}	q _v	p _{fs}	q _v	p _{fs}
		V	Hz	min ⁻¹	W	A	dB(A)	dB(A)	dB(A)	m ³ /h	Pa	cfm	in. wg
1	Δ	480	60	1095	684	1.18	68	74	74	13105	0	7710	0.00
2	Δ	480	60	1080	759	1.24	66	72	72	12215	30	7190	0.12
3	Δ	480	60	1070	810	1.35	64	70	70	11380	55	6695	0.22
4	Y	480	60	895	491	0.71	63	69	68	10765	0	6335	0.00
5	Y	480	60	850	518	0.74	60	66	66	9640	19	5675	0.08
6	Y	480	60	820	550	0.80	58	64	64	8740	33	5145	0.13

Wired = Wiring · U = Voltage · f = Frequency · n = Speed (rpm) · P_e = Power consumption · I = Current draw · LpA_{in} = Sound pressure level intake side · LwA_{in} = Sound power level intake side
LwA_{out} = Sound power level outlet side · q_v = Air flow · p_{fs} = Pressure increase

