

# AC axial fan - HyBlade

sickle-shaped blades (S series)

with square full nozzle

W6D500-GJ03-01 ebmpapst Datasheet

sales@fansco.com

www.fansco.com

Limited partnership · Headquarters Mulfingen

Amtsgericht (court of registration) Stuttgart · HRA 590344

General partner Elektrobau Mulfingen GmbH · Headquarters Mulfingen

Amtsgericht (court of registration) Stuttgart · HRB 590142

## Nominal data

Type	W6D500-GJ03-01						
Motor	M6D110-EF						
Phase		3~	3~	3~	3~	3~	3~
Nominal voltage	VAC	400	400	400	400	480	480
Wiring		Δ	Y	Δ	Y	Δ	Y
Frequency	Hz	50	50	60	60	60	60
Method of obtaining data		ml	ml	ml	ml	ml	ml
Valid for approval/standard		-	-	-	-	-	-
Speed (rpm)	min <sup>-1</sup>	930	800	1050	800	1100	910
Power consumption	W	270	190	380	250	415	295
Current draw	A	0.69	0.4	0.75	0.43	0.78	0.45
Max. back pressure	Pa	75	55	90	55	100	70
Max. back pressure	inH <sub>2</sub> O	0.3	0.22	0.36	0.22	0.4	0.28
Min. ambient temperature	°C	-40	-40	-40	-40	-40	-40
Max. ambient temperature	°C	65	65	65	65	65	65
Starting current	A	2.5		2.3		2.8	

ml = Max. load · me = Max. efficiency · fa = Free air · cs = Customer specification · ce = Customer equipment  
Subject to change



# AC axial fan - HyBlade

sickle-shaped blades (S series)

with square full nozzle

## Technical description

Weight	14.5 kg
Fan size	500 mm
Rotor surface	Painted black
Terminal box material	PP plastic
Blade material	Press-fitted sheet steel blank, sprayed with PP plastic
Fan housing material	Sheet steel, galvanized and coated with black plastic (RAL 9005)
Guard grille material	Steel, coated with black plastic (RAL 9005)
Number of blades	5
Airflow direction	"V"
Direction of rotation	Counterclockwise, viewed toward rotor
Degree of protection	IP54
Insulation class	"F"
Moisture (F) / Environmental (H) protection class	F4-1
Max. permitted ambient temp. for motor (transport/storage)	+ 80 °C
Min. permitted ambient temp. for motor (transport/storage)	- 40 °C
Installation position	Shaft horizontal or rotor on bottom; rotor on top on request
Condensation drainage holes	On rotor side
Mode	S1
Motor bearing	Ball bearing
Touch current according to IEC 60990 (measuring circuit Fig. 4, TN system)	<= 3.5 mA
Electrical hookup	Via terminal box
Motor protection	Thermal overload protector (TOP) with basic insulation
With cable	Axial
Protection class	I (with customer connection of protective earth)
Conformity with standards	EN 61800-5-1
Approval	EAC; VDE; CCC



# AC axial fan - HyBlade

sickle-shaped blades (S series)

with square full nozzle

## Product drawing

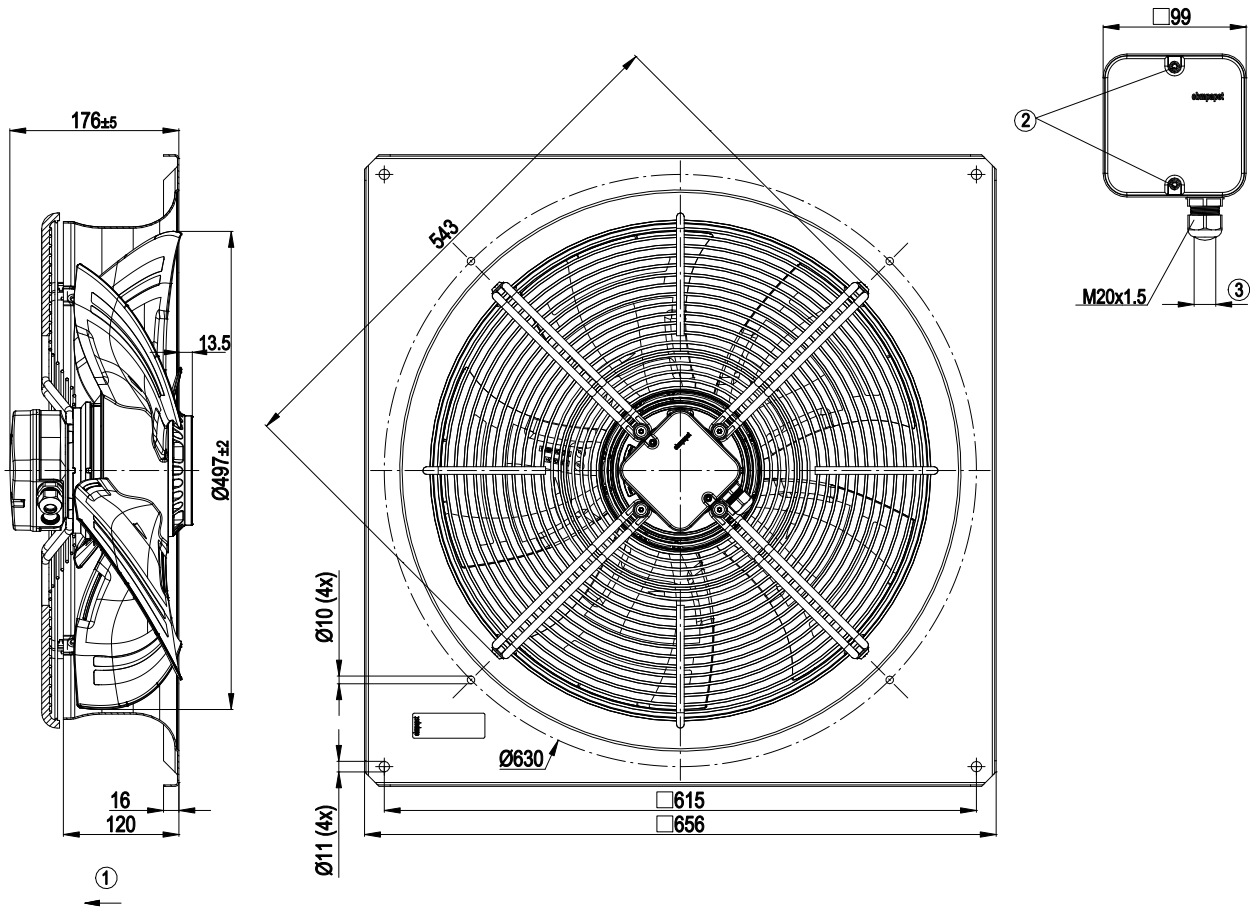

1	Direction of air flow "V"
2	Tightening torque 1.5 ± 0.2 Nm
3	Cable diameter: min. 6 mm, max. 12 mm; tightening torque 2±0.3 Nm



# AC axial fan - HyBlade

sickle-shaped blades (S series)

with square full nozzle

## Connection diagram

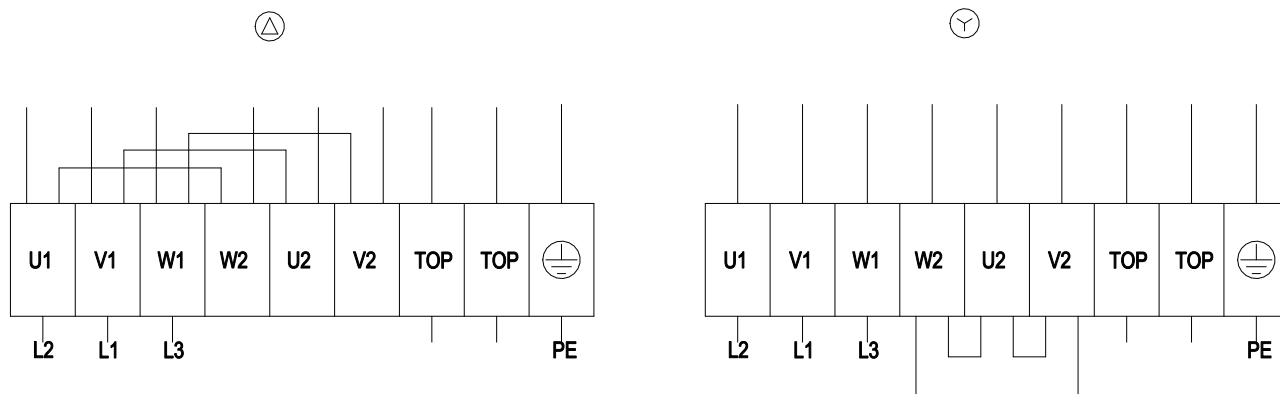

Δ	Delta connection	Y	Star connection	L1	= V1 = blue
L2	= U1 = black	L3	= W1 = brown	W2	yellow
U2	green	V2	white	TOP	2x gray
PE	green/yellow				



# AC axial fan - HyBlade

sickle-shaped blades (S series)

with square full nozzle

## Curves: Air performance 50 Hz

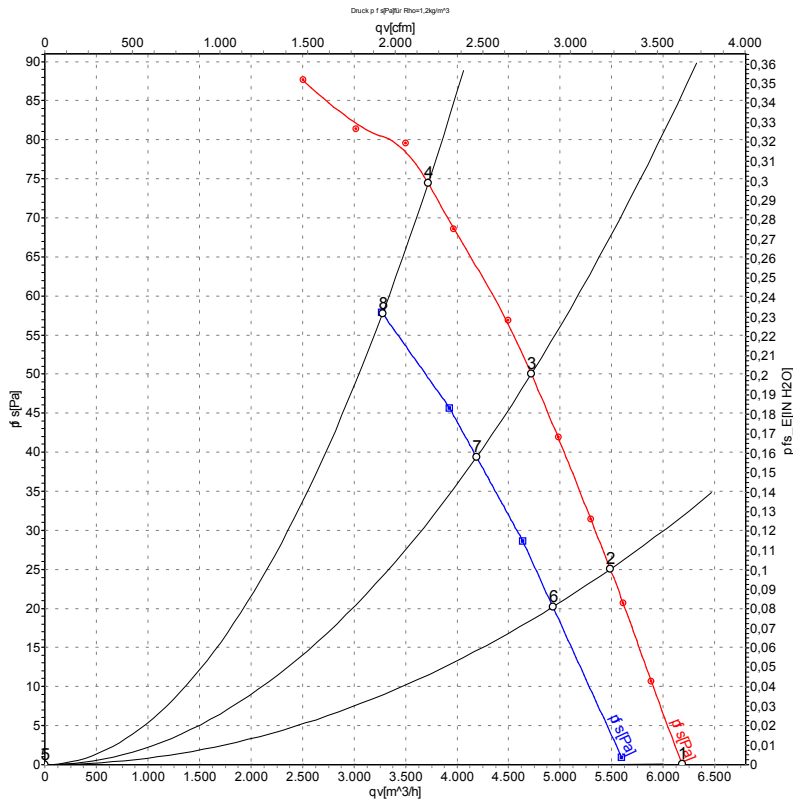

Measurement: LU-105753-1  
Measurement: LU-106651-1

Air performance measured according to ISO 5801 installation category A. For detailed information on the measurement setup, contact ebm-papst. Intake sound level: Sound power level according to ISO 13347 / sound pressure level measured at 1 m distance from fan axis. The values given are valid under the specified measuring conditions and may vary due to conditions of installation. For deviations from the standard configuration, the parameters have to be checked on the installed unit.

## Measured values

	Wired	U	f	n	P <sub>e</sub>	I	LpA <sub>in</sub>	LwA <sub>in</sub>	LwA <sub>out</sub>	qv	p <sub>fs</sub>	qv	p <sub>fs</sub>
		V	Hz	min <sup>-1</sup>	W	A	dB(A)	dB(A)	dB(A)	m <sup>3</sup> /h	Pa	CFM	inH2O
1	Δ	400	50	955	206	0.65	61	67	67	6185	0	3640	0.00
2	Δ	400	50	945	230	0.65	58	64	64	5485	25	3230	0.10
3	Δ	400	50	935	248	0.66	55	62	62	4720	50	2780	0.20
4	Δ	400	50	930	270	0.69	56	63	62	3720	75	2190	0.30
5	Y	400	50	870	145	0.27	59	65	65	5595	0	3295	0.00
6	Y	400	50	850	159	0.29	56	62	62	4930	20	2900	0.08
7	Y	400	50	830	173	0.30	53	59	59	4190	39	2465	0.16
8	Y	400	50	800	190	0.40	52	59	59	3275	55	1930	0.22

Wired = Wiring · U = Power supply · f = Frequency · n = Speed (rpm) · P<sub>e</sub> = Power consumption · I = Current draw · LpA<sub>in</sub> = Sound pressure level intake side · LwA<sub>in</sub> = Sound power level intake side  
LwA<sub>out</sub> = Sound power level outlet side · qv = Air flow · p<sub>fs</sub> = Pressure increase



# AC axial fan - HyBlade

sickle-shaped blades (S series)

with square full nozzle

## Curves: Air performance 60 Hz

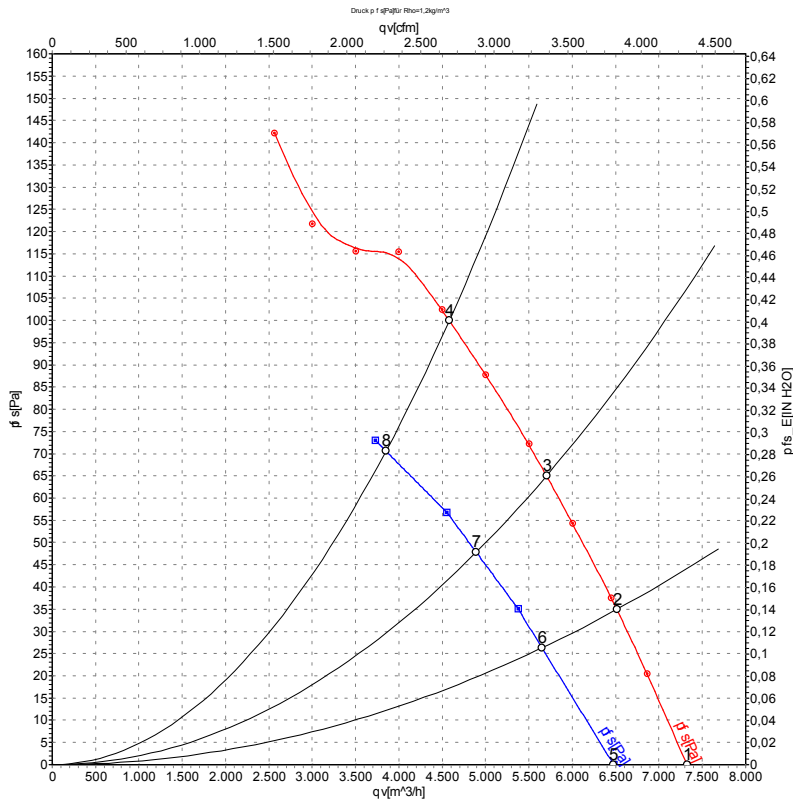

Measurement: LU-106149-1  
Measurement: LU-106413-1

Air performance measured according to ISO 5801 installation category A. For detailed information on the measurement setup, contact ebm-papst. Intake sound level: Sound power level according to ISO 13347 / sound pressure level measured at 1 m distance from fan axis. The values given are valid under the specified measuring conditions and may vary due to conditions of installation. For deviations from the standard configuration, the parameters have to be checked on the installed unit.

## Measured values

	Wired	U	f	n	P <sub>e</sub>	I	LpA <sub>in</sub>	LwA <sub>in</sub>	LwA <sub>out</sub>	qv	p <sub>fs</sub>	qv	p <sub>fs</sub>
		V	Hz	min <sup>-1</sup>	W	A	dB(A)	dB(A)	dB(A)	m <sup>3</sup> /h	Pa	CFM	inH <sub>2</sub> O
1	Δ	480	60	1130	314	0.69	64	70	71	7325	0	4310	0.00
2	Δ	480	60	1120	351	0.70	60	67	67	6515	35	3835	0.14
3	Δ	480	60	1110	380	0.72	59	66	65	5705	65	3355	0.26
4	Δ	480	60	1100	415	0.78	59	66	66	4580	100	2695	0.40
5	Y	480	60	1000	235	0.34	61	68	68	6475	0	3810	0.00
6	Y	480	60	965	257	0.37	58	64	64	5650	26	3325	0.10
7	Y	480	60	945	273	0.39	56	62	62	4890	48	2880	0.19
8	Y	480	60	910	295	0.45	55	62	61	3850	70	2265	0.28

Wired = Wiring · U = Power supply · f = Frequency · n = Speed (rpm) · P<sub>e</sub> = Power consumption · I = Current draw · LpA<sub>in</sub> = Sound pressure level intake side · LwA<sub>in</sub> = Sound power level intake side  
LwA<sub>out</sub> = Sound power level outlet side · qv = Air flow · p<sub>fs</sub> = Pressure increase

