

# AC axial fan

sickle-shaped blades (S series)

with round full nozzle

W6D500-CG01-85 ebmpapst Datasheet

sales@fansco.com

www.fansco.com

Limited partnership · Headquarters Mulfingen

Amtsgericht (court of registration) Stuttgart · HRA 590344

General partner Elektrobau Mulfingen GmbH · Headquarters Mulfingen

Amtsgericht (court of registration) Stuttgart · HRB 590142

## Nominal data

Type	W6D500-CG01-85				
Motor	M6D110-EF				
Phase		3~	3~	3~	3~
Nominal voltage	VAC	230	230	380	400
Wiring		Δ	Δ	Y	Y
Frequency	Hz	50	60	60	50
Method of obtaining data		ml	ml	ml	ml
Valid for approval/standard		-	-	-	-
Speed (rpm)	min <sup>-1</sup>	920	1040	1020	920
Power consumption	W	320	440	420	320
Current draw	A	1.28	1.42	0.8	0.75
Max. back pressure	Pa	75	90	85	75
Max. back pressure	inH <sub>2</sub> O	0.3	0.36	0.34	0.3
Min. ambient temperature	°C	-40	-40	-40	-40
Max. ambient temperature	°C	80	60	60	80
Starting current	A	4.4	4		

ml = Max. load · me = Max. efficiency · fa = Free air · cs = Customer specification · ce = Customer equipment  
Subject to change



# AC axial fan

sickle-shaped blades (S series)

with round full nozzle

## Technical description

Weight	16.6 kg
Fan size	500 mm
Rotor surface	Painted black
Terminal box material	PP plastic
Blade material	Sheet aluminum, painted black
Fan housing material	Sheet steel, galvanized and coated with cement-gray plastic (RAL 7033)
Guard grille material	Steel, coated with cement-gray plastic (RAL 7033)
Number of blades	5
Blade pitch	0°
Airflow direction	"A"
Direction of rotation	Clockwise, viewed toward rotor
Degree of protection	IP54
Insulation class	"F"
Moisture (F) / Environmental (H) protection class	F4-2
Max. permitted ambient temp. for motor (transport/storage)	+ 80 °C
Min. permitted ambient temp. for motor (transport/storage)	- 40 °C
Installation position	Shaft horizontal or rotor on top; rotor on bottom on request
Condensation drainage holes	On stator side
Mode	S1
Motor bearing	Ball bearing
Touch current according to IEC 60990 (measuring circuit Fig. 4, TN system)	<= 3.5 mA
Electrical hookup	Via terminal box
Motor protection	Thermal overload protector (TOP) with basic insulation
With cable	Axial
Protection class	I (with customer connection of protective earth)
Conformity with standards	EN 61800-5-1
Approval	EAC; VDE



# AC axial fan

sickle-shaped blades (S series)  
with round full nozzle

## Product drawing

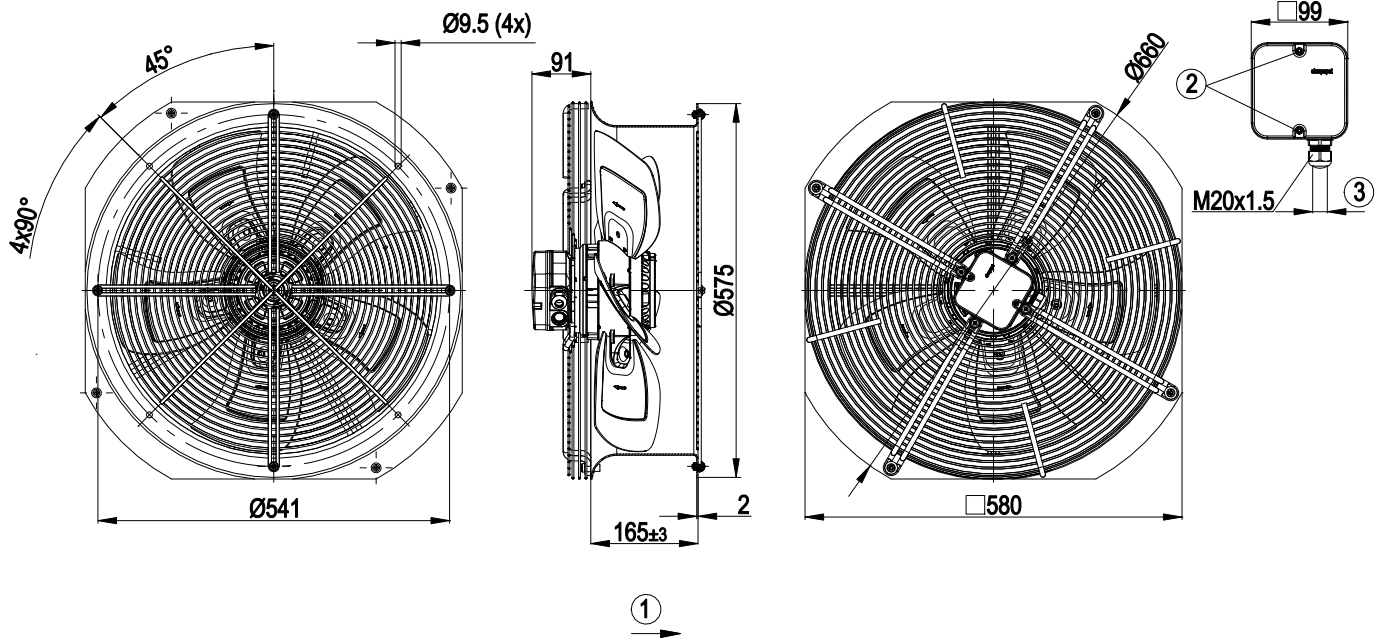

1	Direction of air flow "A"
2	Tightening torque $1.5 \pm 0.2$ Nm
3	Cable diameter: min. 7 mm, max. 14 mm; tightening torque $2 \pm 0.3$ Nm



# AC axial fan

sickle-shaped blades (S series)  
with round full nozzle

## Connection diagram

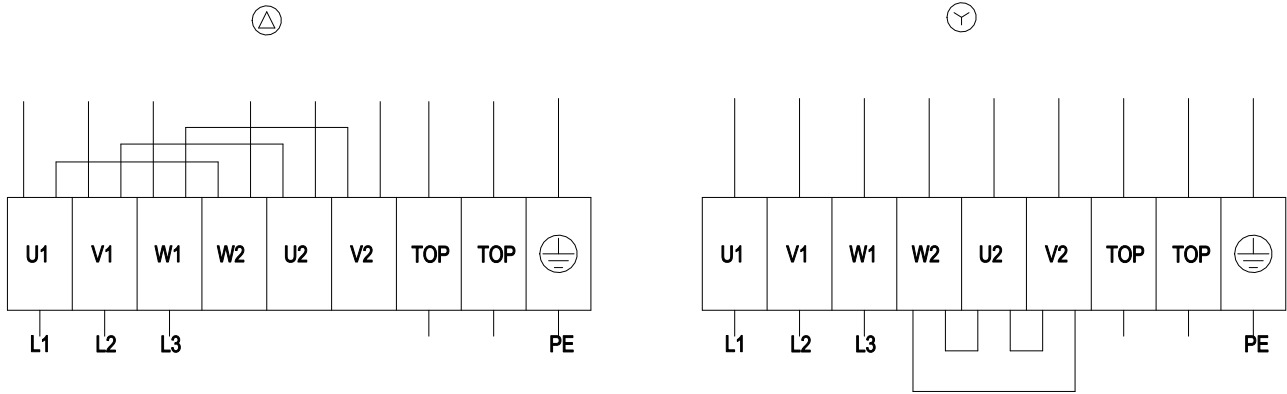

Δ	Delta connection	Y	Star connection	L1	= U1 = black
L2	= V1 = blue	L3	= W1 = brown	W2	yellow
U2	green	V2	white	TOP	2x gray
PE	green/yellow				



# AC axial fan

sickle-shaped blades (S series)  
with round full nozzle

## Curves: Air performance 50 Hz

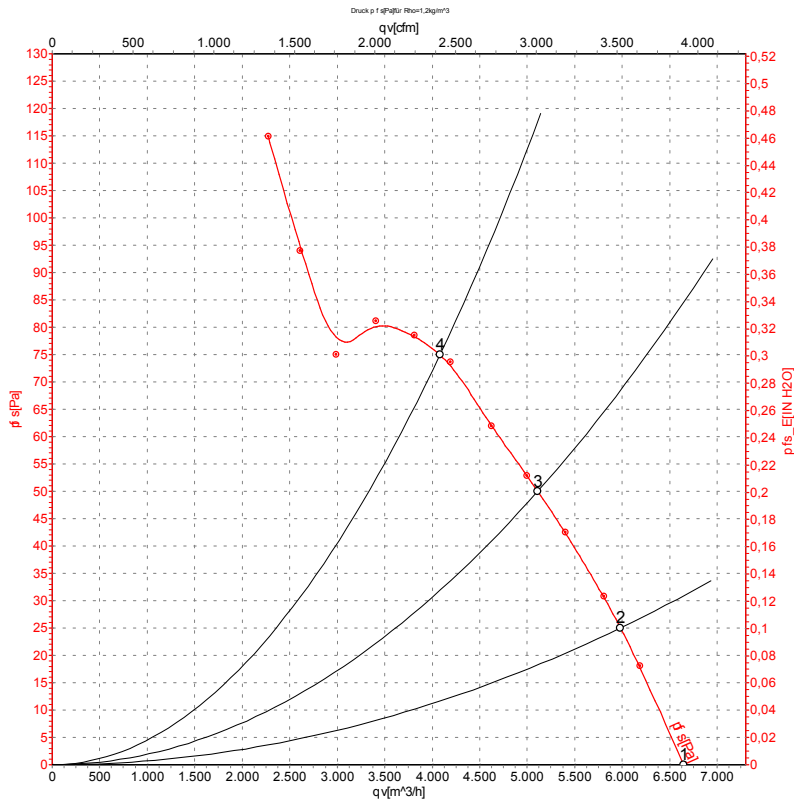

Measurement: LU-101541-1

Air performance measured according to ISO 5801 installation category A. For detailed information on the measurement setup, contact ebm-papst. Intake sound level: Sound power level according to ISO 13347 / sound pressure level measured at 1 m distance from fan axis. The values given are valid under the specified measuring conditions and may vary due to conditions of installation. For deviations from the standard configuration, the parameters have to be checked on the installed unit.

## Measured values

	Wired	U	f	n	P <sub>e</sub>	I	LpA <sub>in</sub>	LwA <sub>in</sub>	qv	P <sub>fs</sub>	qv	P <sub>fs</sub>
		V	Hz	min <sup>-1</sup>	W	A	dB(A)	dB(A)	m <sup>3</sup> /h	Pa	CFM	inH <sub>2</sub> O
1	Y	400	50	940	250	0.71	63	69	6645	0	3910	0.00
2	Y	400	50	935	266	0.71	63	70	5980	25	3520	0.10
3	Y	400	50	930	286	0.72	64	70	5110	50	3010	0.20
4	Y	400	50	920	320	0.75	64	71	4080	75	2405	0.30

Wired = Wiring · U = Power supply · f = Frequency · n = Speed (rpm) · P<sub>e</sub> = Power consumption · I = Current draw · LpA<sub>in</sub> = Sound pressure level intake side · LwA<sub>in</sub> = Sound power level intake side  
qv = Air flow · P<sub>fs</sub> = Pressure increase



# AC axial fan

sickle-shaped blades (S series)  
with round full nozzle

## Curves: Air performance 60 Hz

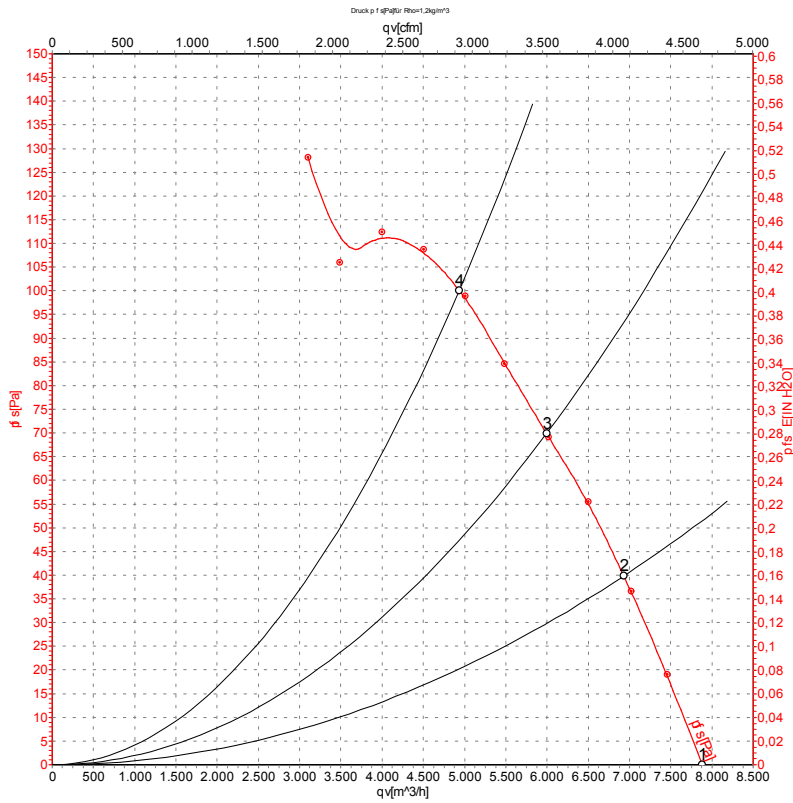

Measurement: LU-101542-1

Air performance measured according to ISO 5801 installation category A. For detailed information on the measurement setup, contact ebm-papst. Intake sound level: Sound power level according to ISO 13347 / sound pressure level measured at 1 m distance from fan axis. The values given are valid under the specified measuring conditions and may vary due to conditions of installation. For deviations from the standard configuration, the parameters have to be checked on the installed unit.

## Measured values

	Wired	U	f	n	P <sub>e</sub>	I	LpA <sub>in</sub>	LwA <sub>in</sub>	qv	P <sub>fs</sub>	qv	P <sub>fs</sub>
		V	Hz	min <sup>-1</sup>	W	A	dB(A)	dB(A)	m <sup>3</sup> /h	Pa	CFM	inH <sub>2</sub> O
1	Y	480	60	1110	380	0.75	66	73	7885	0	4640	0.00
2	Y	480	60	1105	418	0.78	67	73	6930	40	4080	0.16
3	Y	480	60	1095	448	0.80	67	74	5995	70	3530	0.28
4	Y	480	60	1080	490	0.85	68	75	4935	100	2905	0.40

Wired = Wiring · U = Power supply · f = Frequency · n = Speed (rpm) · P<sub>e</sub> = Power consumption · I = Current draw · LpA<sub>in</sub> = Sound pressure level intake side · LwA<sub>in</sub> = Sound power level intake side  
qv = Air flow · P<sub>fs</sub> = Pressure increase

