

AC axial fan

straight blades (A series)

W4S250-CA02-01 ebmpapst Datasheet

sales@fansco.com

www.fansco.com

Nominal data

Type	W4S250-CA02-01			
Motor	M4S068-CF			
Phase		1~	1~	1~
Nominal voltage	VAC	230	230	230
Frequency	Hz	50	60	60
Method of obtaining data		fa	fa	fa
Valid for approval/standard		CE	UL	CE
Speed (rpm)	min ⁻¹	1400	1620	1620
Power consumption	W	72	75	67
Current draw	A	0.53	0.33	0.46
Max. back pressure	Pa	80	100	100
Max. back pressure	in. wg	0.32	0.4	0.4
Min. ambient temperature	°C	-25	-25	-25
Max. ambient temperature	°C	40	50	50

ml = Max. load · me = Max. efficiency · fa = Free air · cs = Customer specification · ce = Customer equipment
Subject to change



AC axial fan

straight blades (A series)

with round full nozzle

Technical description

Weight	2.84 kg
Size	250 mm
Motor size	68
Rotor surface	Painted black
Blade material	Sheet steel, painted black
Fan housing material	Sheet steel, galvanized and coated with black plastic (RAL 9005)
Guard grille material	Steel, coated with black plastic (RAL 9005)
Number of blades	5
Airflow direction	V
Direction of rotation	Counterclockwise, viewed toward rotor
Degree of protection	IP44
Insulation class	"B"
Moisture (F) / Environmental (H) protection class	H1
Max. permitted ambient temp. for motor (transport/storage)	+80 °C
Min. permitted ambient temp. for motor (transport/storage)	-40 °C
Installation position	Shaft horizontal or rotor on bottom; rotor on top on request
Condensation drainage holes	On rotor side
Mode	S1
Motor bearing	Ball bearing
Touch current according to IEC 60990 (measuring circuit Fig. 4, TN system)	< 0.75 mA
Motor protection	Thermal overload protector (TOP) internally connected
With cable	Lateral
Protection class assignment	I; If a protective earth is connected by the customer This component for installation may have several local protection classes. This information relates to this component's basic design. The final protection class is based on the component's intended installation and connection.
Conformity with standards	EN 60034-1; EN 60204-1; EN 60335-1; CE
Approval	EAC



AC axial fan

straight blades (A series)
with round full nozzle

Product drawing

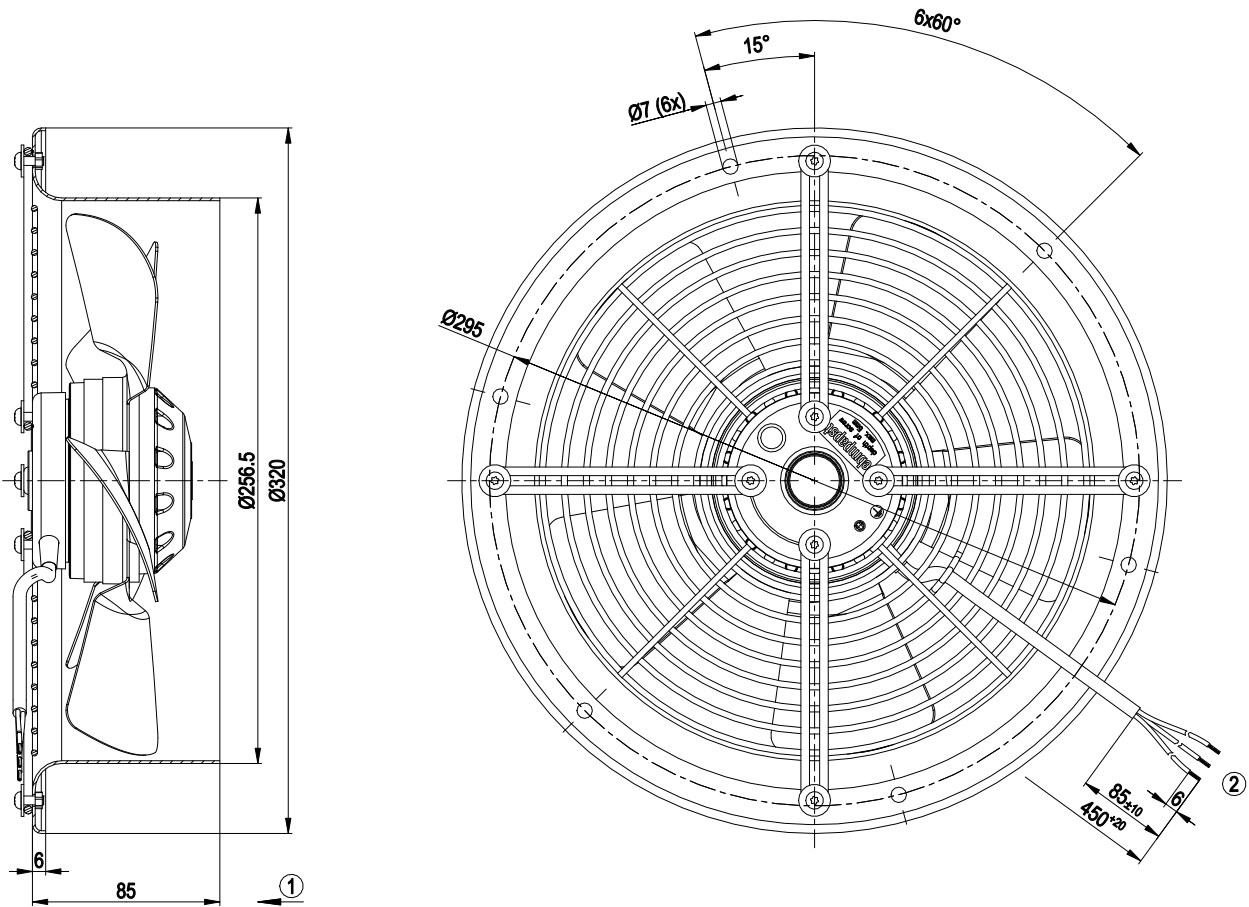

- | | |
|---|---|
| 1 | Airflow direction "V" |
| 2 | Cable PVC 3G 0.5 mm ² , 3x crimped splices |



AC axial fan

straight blades (A series)
with round full nozzle

Connection diagram

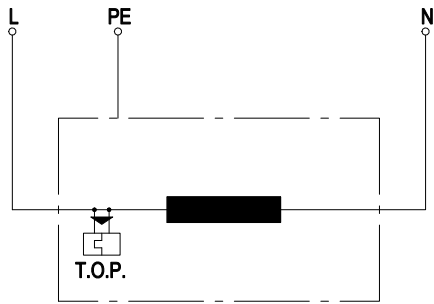

L	= blue
PE	= green/yellow
N	= black
TOP	= thermal overload protector

AC axial fan

straight blades (A series)
with round full nozzle

Curves: Air performance 50 Hz

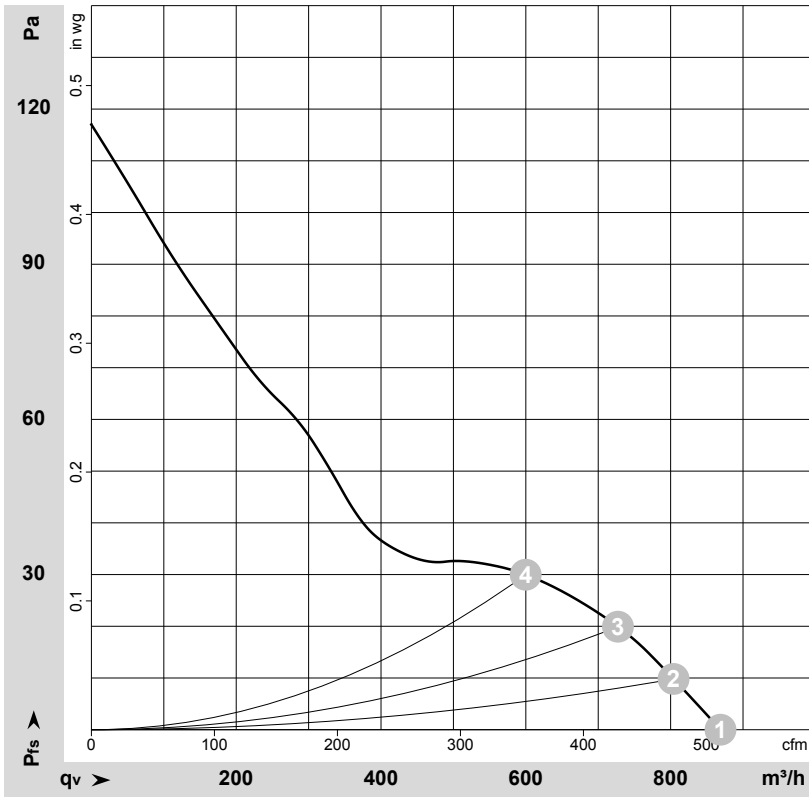

$\rho = 1.15 \text{ kg/m}^3 \pm 2 \%$

Measurement: LU-16243-1

Air performance measured according to ISO 5801 installation category A. For detailed information on the measurement setup, contact ebmpapst. Intake sound level: Sound power level according to ISO 13347 / sound pressure level measured at 1 m distance from fan axis. The values given are valid under the specified measuring conditions and may vary due to conditions of installation. For deviations from the standard configuration, the parameters have to be checked on the installed unit.

Measured values

	U	f	n	P _e	I	q _v	P _{fs}	q _v	P _{fs}
	V	Hz	min ⁻¹	W	A	m ³ /h	Pa	cfm	in. wg
1	230	50	1400	72	0.53	870	0	510	0.00
2	230	50	1400	70	0.52	805	10	475	0.04
3	230	50	1400	70	0.52	725	20	430	0.08
4	230	50	1390	70	0.52	600	30	355	0.12

U = Voltage · f = Frequency · n = Speed (rpm) · P_e = Power consumption · I = Current draw · q_v = Air flow · P_{fs} = Pressure increase



Curves: Air performance 60 Hz

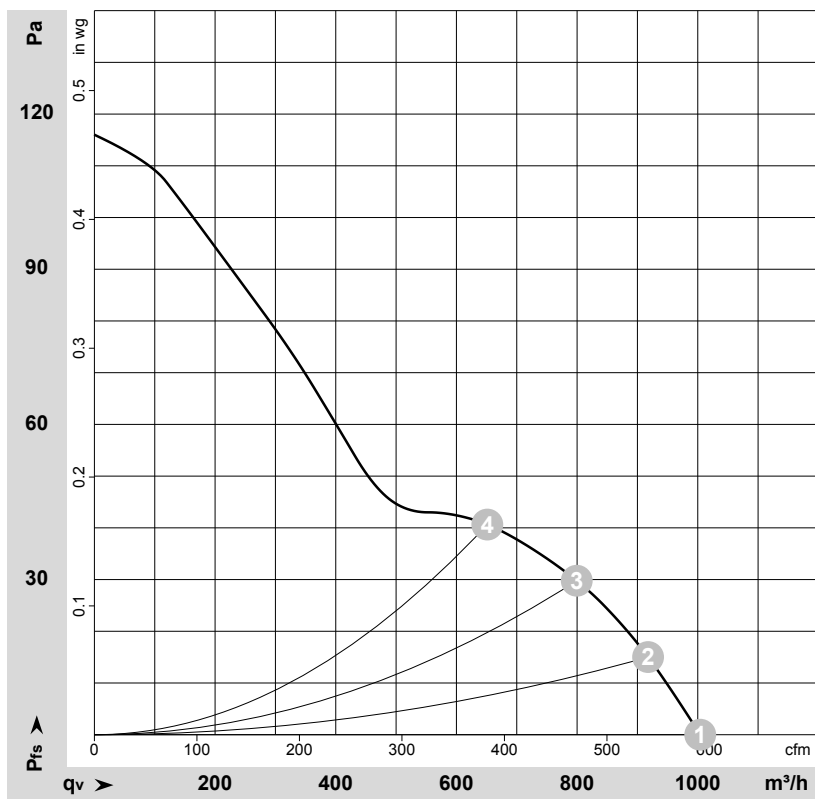

$\rho = 1.15 \text{ kg/m}^3 \pm 2 \%$

Measurement: LU-16244-1

Air performance measured according to ISO 5801 installation category A. For detailed information on the measurement setup, contact ebmpapst. Intake sound level: Sound power level according to ISO 13347 / sound pressure level measured at 1 m distance from fan axis. The values given are valid under the specified measuring conditions and may vary due to conditions of installation. For deviations from the standard configuration, the parameters have to be checked on the installed unit.

Measured values

	U	f	n	P _e	I	q _v	p _{fs}	q _v	p _{fs}
	V	Hz	min ⁻¹	W	A	m ³ /h	Pa	cfm	in. wg
1	230	60	1620	67	0.46	1005	0	590	0.00
2	230	60	1610	66	0.45	920	15	540	0.06
3	230	60	1605	67	0.46	800	30	470	0.12
4	230	60	1600	67	0.46	650	40	385	0.16

U = Voltage · f = Frequency · n = Speed (rpm) · P_e = Power consumption · I = Current draw · q_v = Air flow · p_{fs} = Pressure increase

