

AC axial fan

straight blades (A series)

with round full nozzle

W4S200-CA02-02 ebmpapst Datasheet

sales@fansco.com

www.fansco.com

Nominal data

Type	W4S200-CA02-02		
Motor	M4S068-BF		
Phase		1~	1~
Nominal voltage	VAC	230	230
Frequency	Hz	50	60
Method of obtaining data		fa	fa
Valid for approval/standard		CE	CE
Speed (rpm)	min ⁻¹	1350	1600
Power consumption	W	42	37
Current draw	A	0.31	0.26
Min. ambient temperature	°C	-25	-25
Max. ambient temperature	°C	50	65

ml = Max. load · me = Max. efficiency · fa = Free air · cs = Customer specification · ce = Customer equipment
Subject to change



AC axial fan

straight blades (A series)

with round full nozzle

Technical description

Weight	2.1 kg
Fan size	200 mm
Rotor surface	Painted black
Blade material	Sheet steel, galvanized
Fan housing material	Sheet steel, galvanized
Guard grille material	Steel, coated with black plastic (RAL 9005)
Number of blades	5
Airflow direction	"A"
Direction of rotation	Clockwise, viewed toward rotor
Degree of protection	IP44; installation- and position-dependent as per EN 60034-5
Insulation class	"B"
Moisture (F) / Environmental (H) protection class	H1
Max. permitted ambient temp. for motor (transport/storage)	+ 80 °C
Min. permitted ambient temp. for motor (transport/storage)	- 40 °C
Installation position	Shaft horizontal or rotor on bottom; rotor on top on request
Condensation drainage holes	On rotor side
Mode	S1
Motor bearing	Ball bearing
Touch current according to IEC 60990 (measuring circuit Fig. 4, TN system)	< 0.75 mA
Motor protection	Thermal overload protector (TOP) internally connected
With cable	Lateral
Protection class	I (with customer connection of protective earth)
Conformity with standards	EN 60335-1; CE



AC axial fan

straight blades (A series)
with round full nozzle

Product drawing

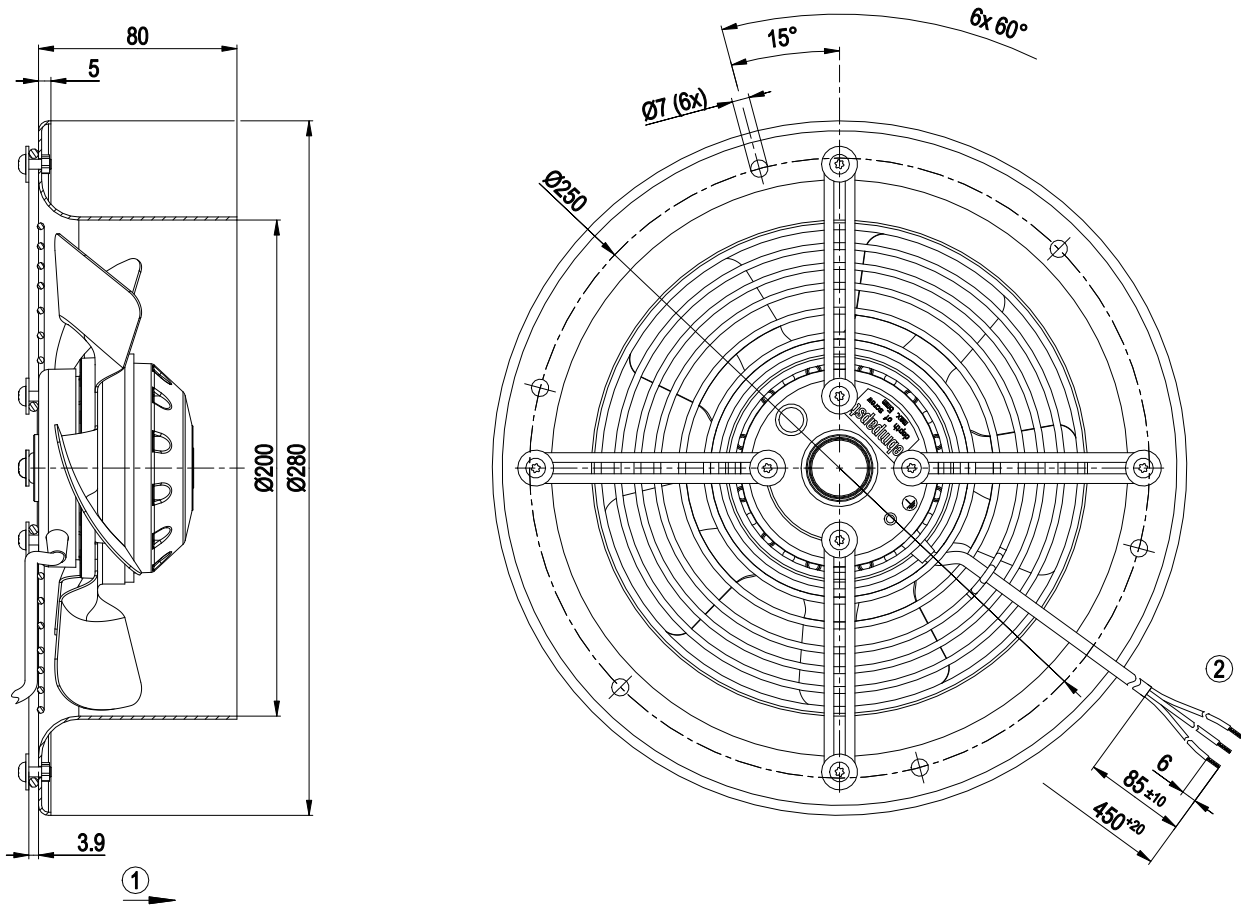

- | | |
|---|---|
| 1 | Direction of air flow "A" |
| 2 | Cable PVC 3G 0.5 mm ² , 3x crimped splices |

Connection diagram

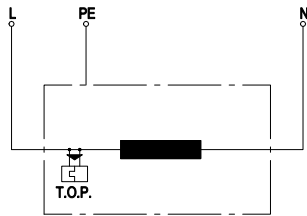

- | | |
|-----|------------------------------|
| L | = blue |
| PE | = green/yellow |
| N | = brown |
| TOP | = thermal overload protector |



AC axial fan

straight blades (A series)
with round full nozzle

Curves: Air performance 50 Hz

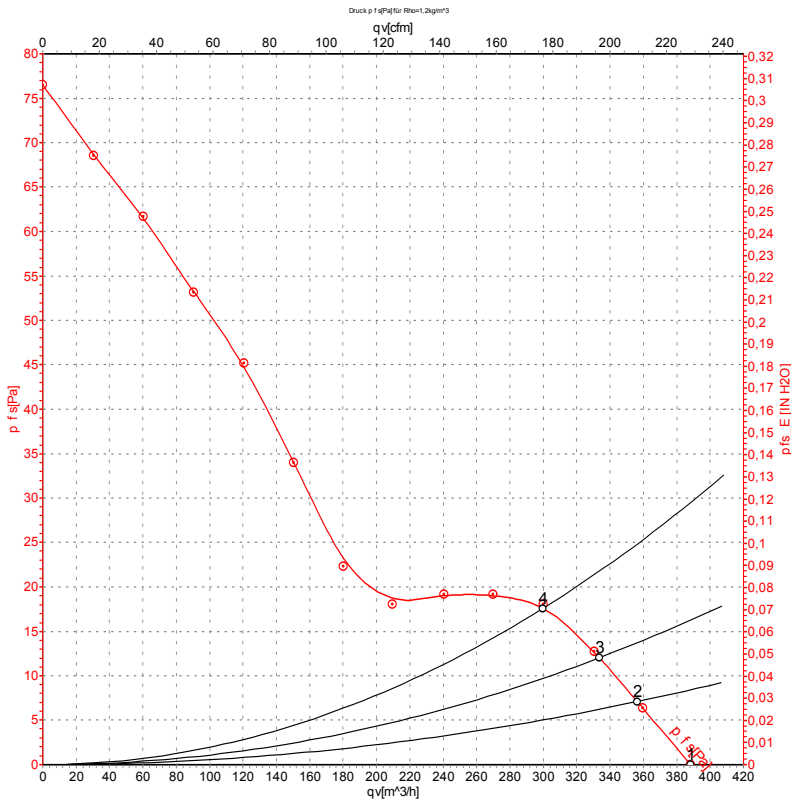

Measurement: LU-78397-1

Air performance measured according to ISO 5801 installation category A. For detailed information on the measurement setup, contact ebmpapst. Intake sound level: Sound power level according to ISO 13347 / sound pressure level measured at 1 m distance from fan axis. The values given are valid under the specified measuring conditions and may vary due to conditions of installation. For deviations from the standard configuration, the parameters have to be checked on the installed unit.

Measured values

	U	f	n	Pe	I	qv	pfs	qv	pfs
	V	Hz	min ⁻¹	W	A	m ³ /h	Pa	cfm	in. wg
1	230	50	1380	37	0.27	390	0	230	0.00
2	230	50	1380	37	0.27	355	7	210	0.03
3	230	50	1375	37	0.28	335	12	195	0.05
4	230	50	1375	38	0.28	300	18	175	0.07

U = Power supply · f = Frequency · n = Speed (rpm) · Pe = Power consumption · I = Current draw · qv = Air flow · pfs = Pressure increase



AC axial fan

straight blades (A series)
with round full nozzle

Curves: Air performance 60 Hz

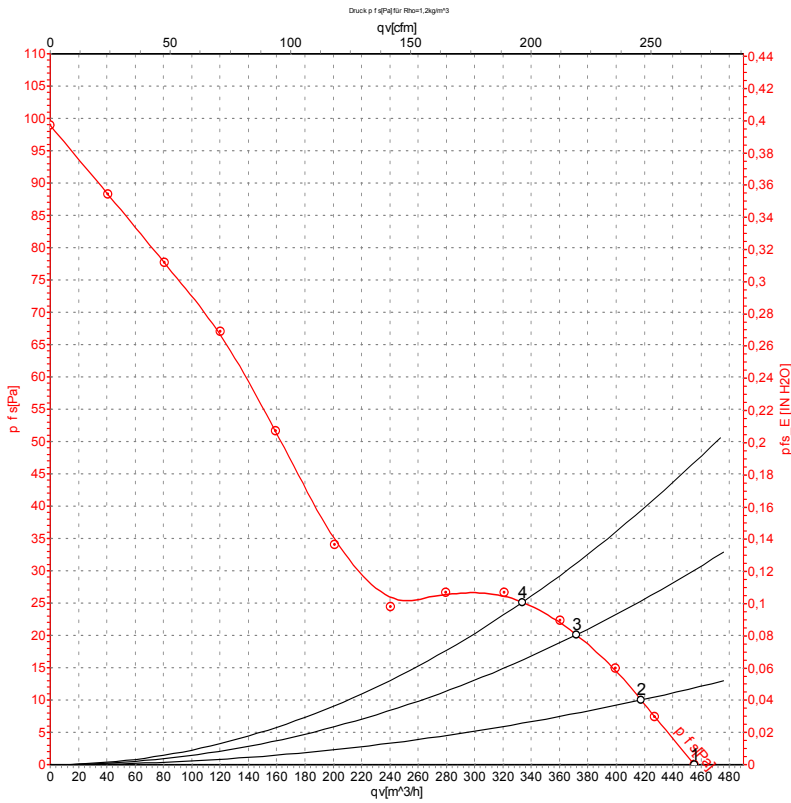

Measurement: LU-78398-1

Air performance measured according to ISO 5801 installation category A. For detailed information on the measurement setup, contact ebm-papst. Intake sound level: Sound power level according to ISO 13347 / sound pressure level measured at 1 m distance from fan axis. The values given are valid under the specified measuring conditions and may vary due to conditions of installation. For deviations from the standard configuration, the parameters have to be checked on the installed unit.

Measured values

	U	f	n	P _e	I	q _v	P _{fs}	q _v	P _{fs}
	V	Hz	min ⁻¹	W	A	m ³ /h	Pa	cfm	in. wg
1	230	60	1630	32	0.22	455	0	270	0.00
2	230	60	1610	33	0.23	420	10	245	0.04
3	230	60	1600	33	0.23	370	20	220	0.08
4	230	60	1600	33	0.23	335	25	195	0.10

U = Power supply · f = Frequency · n = Speed (rpm) · P_e = Power consumption · I = Current draw · q_v = Air flow · P_{fs} = Pressure increase

