

# AC axial fan

sickle-shaped blades (S series)

with round full nozzle

W4E250-CH02-01 ebmpapst Datasheet

sales@fansco.com

www.fansco.com

## Nominal data

Type	W4E250-CH02-01		
Motor	M4E068-BF		
Phase		1~	1~
Nominal voltage	VAC	230	230
Frequency	Hz	50	60
Method of obtaining data		fa	fa
Valid for approval/standard		CE	CE
Speed (rpm)	min <sup>-1</sup>	1400	1630
Power consumption	W	42	45
Current draw	A	0.19	0.20
Capacitor	μF	1.5	1.5
Capacitor voltage	VDB	400	400
Capacitor standard		S0 (CE)	
Max. back pressure	Pa	80	100
Max. back pressure	in. wg	0.32	0.4
Min. ambient temperature	°C	-25	-25
Max. ambient temperature	°C	55	70
Starting current	A	0.33	0.32

ml = Max. load · me = Max. efficiency · fa = Free air · cs = Customer specification · ce = Customer equipment  
Subject to change



# AC axial fan

sickle-shaped blades (S series)

with round full nozzle

## Technical description

Weight	2.92 kg
Size	250 mm
Motor size	68
Rotor surface	Painted black
Blade material	Sheet steel, painted black
Fan housing material	Sheet steel, pre-galvanized and coated with black plastic
Guard grille material	Steel, phosphated and coated with black plastic
Number of blades	7
Airflow direction	V
Direction of rotation	Counterclockwise, viewed toward rotor
Degree of protection	IP44
Insulation class	"B"
Moisture (F) / Environmental (H) protection class	H1+
Max. permitted ambient temp. for motor (transport/storage)	+ 80 °C
Min. permitted ambient temp. for motor (transport/storage)	- 40 °C
Installation position	Shaft horizontal or rotor on bottom; rotor on top on request
Condensation drainage holes	On rotor side
Mode	S1
Motor bearing	Ball bearing
Touch current according to IEC 60990 (measuring circuit Fig. 4, TN system)	< 0.75 mA
Motor protection	Thermal overload protector (TOP) internally connected
With cable	Variable
Protection class	I (with customer connection of protective earth)
Conformity with standards	EN 60335-1; CE
Comment on CE	Ecodesign Directive 2009/125/EC + Fan Directive (EC) No. 327/2011 does not apply, as power consumption <125W.



# AC axial fan

sickle-shaped blades (S series)  
with round full nozzle

## Product drawing

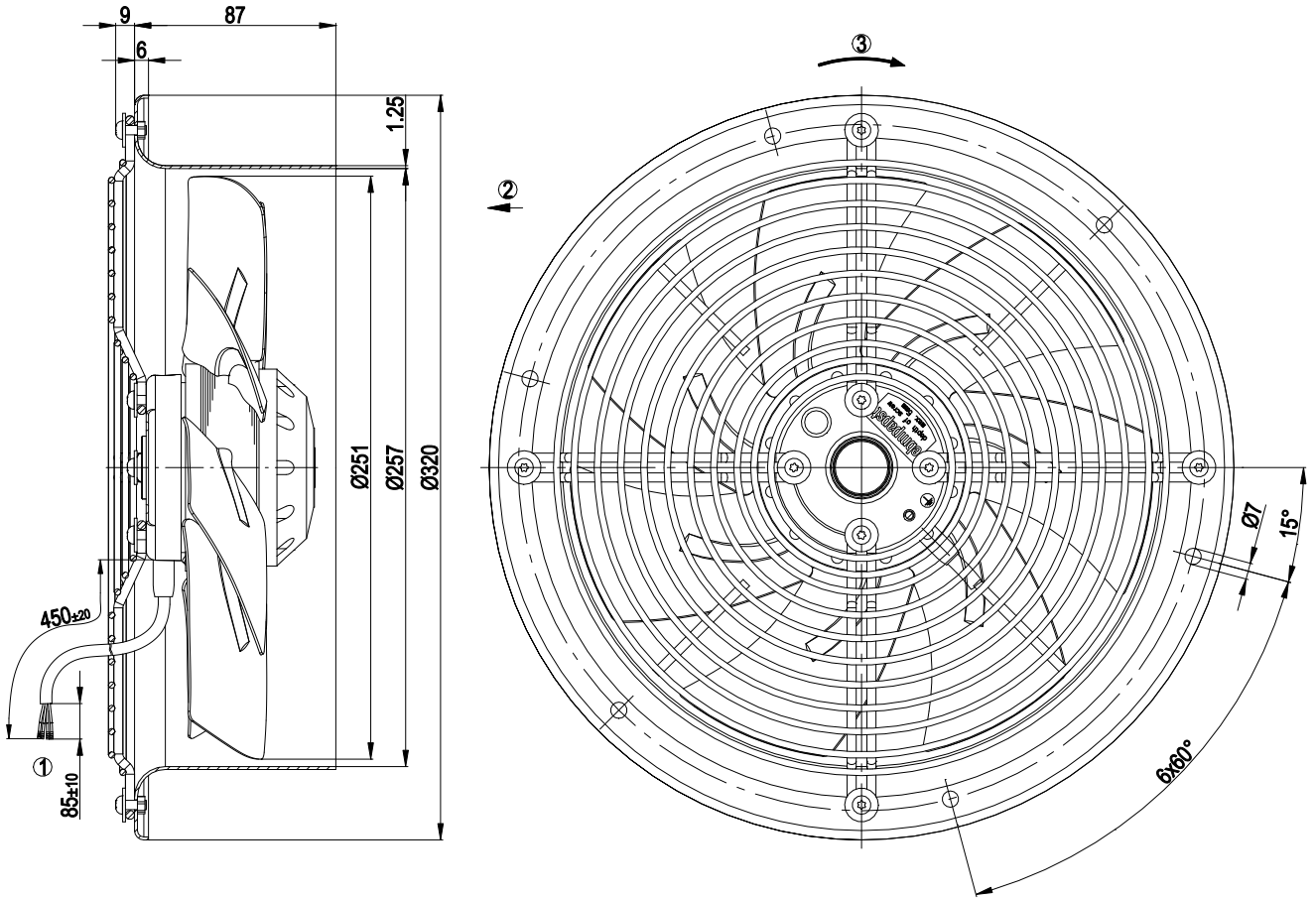

1	Cable PVC, 4x crimped splices
2	Direction of air flow "V"
3	Direction of rotation counterclockwise, viewed toward rotor

## Connection diagram

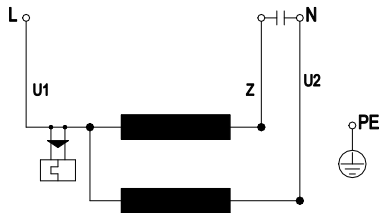

U1	blue	Z	brown	U2	black
PE	green/yellow				



# AC axial fan

sickle-shaped blades (S series)  
with round full nozzle

## Curves: Air performance 50 Hz

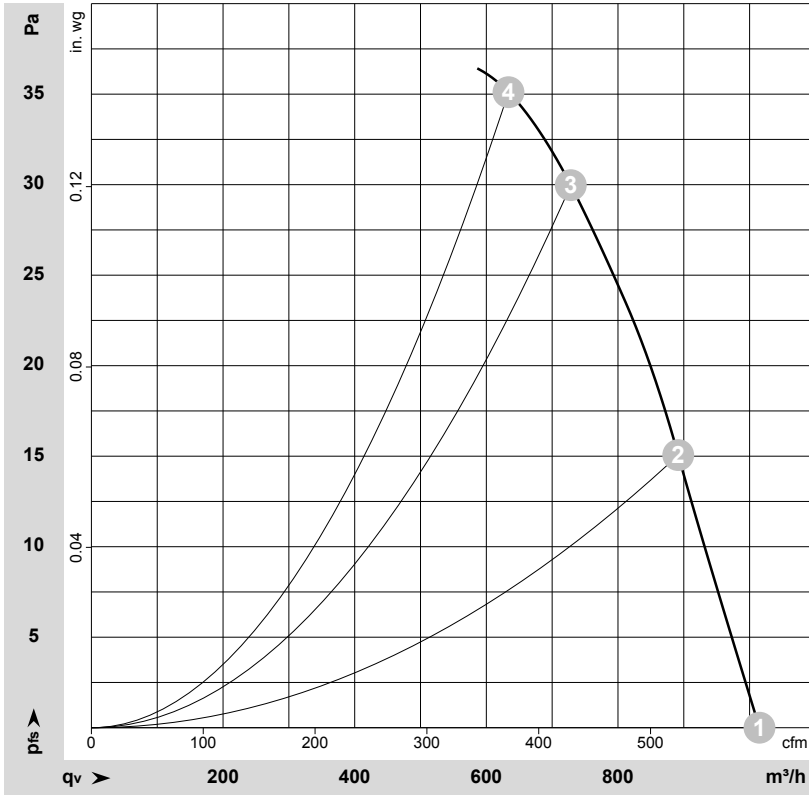

$\rho = 1.15 \text{ kg/m}^3 \pm 2 \%$

Measurement: LU-60036-1

Air performance measured according to ISO 5801 installation category A. For detailed information on the measurement setup, contact ebmpapst. Intake sound level: Sound power level according to ISO 13347 / sound pressure level measured at 1 m distance from fan axis. The values given are valid under the specified measuring conditions and may vary due to conditions of installation. For deviations from the standard configuration, the parameters have to be checked on the installed unit.

## Measured values

	Wired	U	f	n	P <sub>e</sub>	I	q <sub>v</sub>	p <sub>fs</sub>	q <sub>v</sub>	p <sub>fs</sub>
		V	Hz	min <sup>-1</sup>	W	A	m <sup>3</sup> /h	Pa	cfm	in. wg
1	1~	230	50	1400	42	0.19	1015	0	595	0.00
2	1~	230	50	1385	43	0.20	890	15	525	0.06
3	1~	230	50	1370	44	0.20	730	30	430	0.12
4	1~	230	50	1360	45	0.20	635	35	375	0.14

Wired = Wiring · U = Voltage · f = Frequency · n = Speed (rpm) · P<sub>e</sub> = Power consumption · I = Current draw · q<sub>v</sub> = Air flow · p<sub>fs</sub> = Pressure increase



# AC axial fan

sickle-shaped blades (S series)  
with round full nozzle

## Curves: Air performance 60 Hz

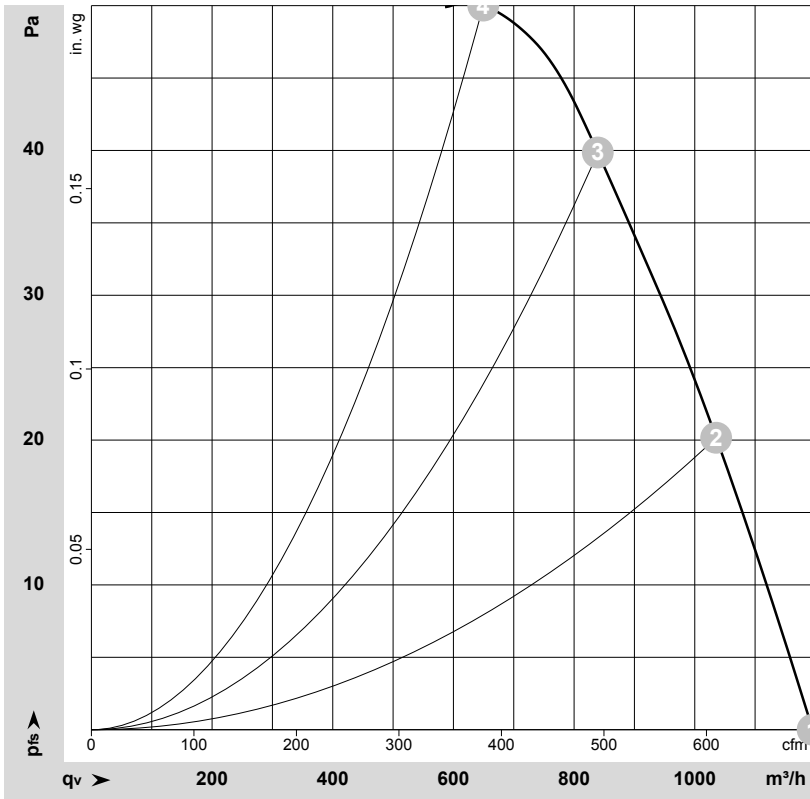

$\rho = 1.15 \text{ kg/m}^3 \pm 2 \%$

Measurement: LU-60037-1

Air performance measured according to ISO 5801 installation category A. For detailed information on the measurement setup, contact ebmpapst. Intake sound level: Sound power level according to ISO 13347 / sound pressure level measured at 1 m distance from fan axis. The values given are valid under the specified measuring conditions and may vary due to conditions of installation. For deviations from the standard configuration, the parameters have to be checked on the installed unit.

## Measured values

	Wired	U	f	n	P <sub>e</sub>	I	q <sub>v</sub>	P <sub>fs</sub>	q <sub>v</sub>	P <sub>fs</sub>
		V	Hz	min <sup>-1</sup>	W	A	m <sup>3</sup> /h	Pa	cfm	in. wg
1	1~	230	60	1630	45	0.20	1195	0	705	0.00
2	1~	230	60	1625	47	0.21	1035	20	610	0.08
3	1~	230	60	1585	49	0.21	840	40	495	0.16
4	1~	230	60	1580	49	0.21	650	50	380	0.20

Wired = Wiring · U = Voltage · f = Frequency · n = Speed (rpm) · P<sub>e</sub> = Power consumption · I = Current draw · q<sub>v</sub> = Air flow · P<sub>fs</sub> = Pressure increase

