

AC axial fan

sickle-shaped blades (S series)

Duct fan, for rail applications

W4D710-CK01-05 ebmpapst Datasheet

sales@fansco.com

www.fansco.com

Nominal data

Type	W4D710-CK01-05		
Motor	M4D138-LA		
Phase		3~	3~
Nominal voltage	VAC	400	400
Wiring		Δ	Y
Frequency	Hz	50	50
Method of obtaining data		ml	ml
Valid for approval/standard		-	-
Speed (rpm)	min ⁻¹	1300	990
Power consumption	W	2870	1830
Current draw	A	5.2	3.1
Max. back pressure	Pa	220	125
Max. back pressure	in. wg	0.88	0.5
Min. ambient temperature	°C	-40	-40
Max. ambient temperature	°C	55	55
Starting current	A	19	6.5

ml = Max. load · me = Max. efficiency · fa = Free air · cs = Customer specification · ce = Customer equipment
Subject to change



AC axial fan

sickle-shaped blades (S series)

Duct fan, for rail applications

Technical description

Weight	42.8 kg
Size	710 mm
Motor size	138
Rotor surface	Painted black
Terminal box material	Die-cast aluminum, painted black
Blade material	Die-cast aluminum, painted black
Support ring material	Steel, coated with black plastic (RAL 9005)
Fan housing material	Sheet steel, galvanized and coated with black plastic (RAL 9005)
Guard grille material	Steel, coated with black plastic (RAL 9005)
Number of blades	5
Blade pitch	-5°
Airflow direction	V
Direction of rotation	Clockwise, viewed toward rotor
Degree of protection	IP54
Insulation class	"F"
Moisture (F) / Environmental (H) protection class	H2
Max. permitted ambient temp. for motor (transport/storage)	+80 °C
Min. permitted ambient temp. for motor (transport/storage)	-40 °C
Installation position	Any
Condensation drainage holes	On rotor and stator sides
Mode	S1
Motor bearing	Ball bearing
Touch current according to IEC 60990 (measuring circuit Fig. 4, TN system)	≤ 3.5 mA
Electrical hookup	Terminal box
Motor protection	Thermal overload protector (TOP) with basic insulation
With cable	Lateral
Protection class assignment	I; If a protective earth is connected by the customer This component for installation may have several local protection classes. This information relates to this component's basic design. The final protection class is based on the component's intended installation and connection.
Conformity with standards	EN 60034-1 (2010)
Comment on CE	Operation only permitted outside the European Economic Area
Approval	EAC



AC axial fan

sickle-shaped blades (S series)

Duct fan, for rail applications

Product drawing

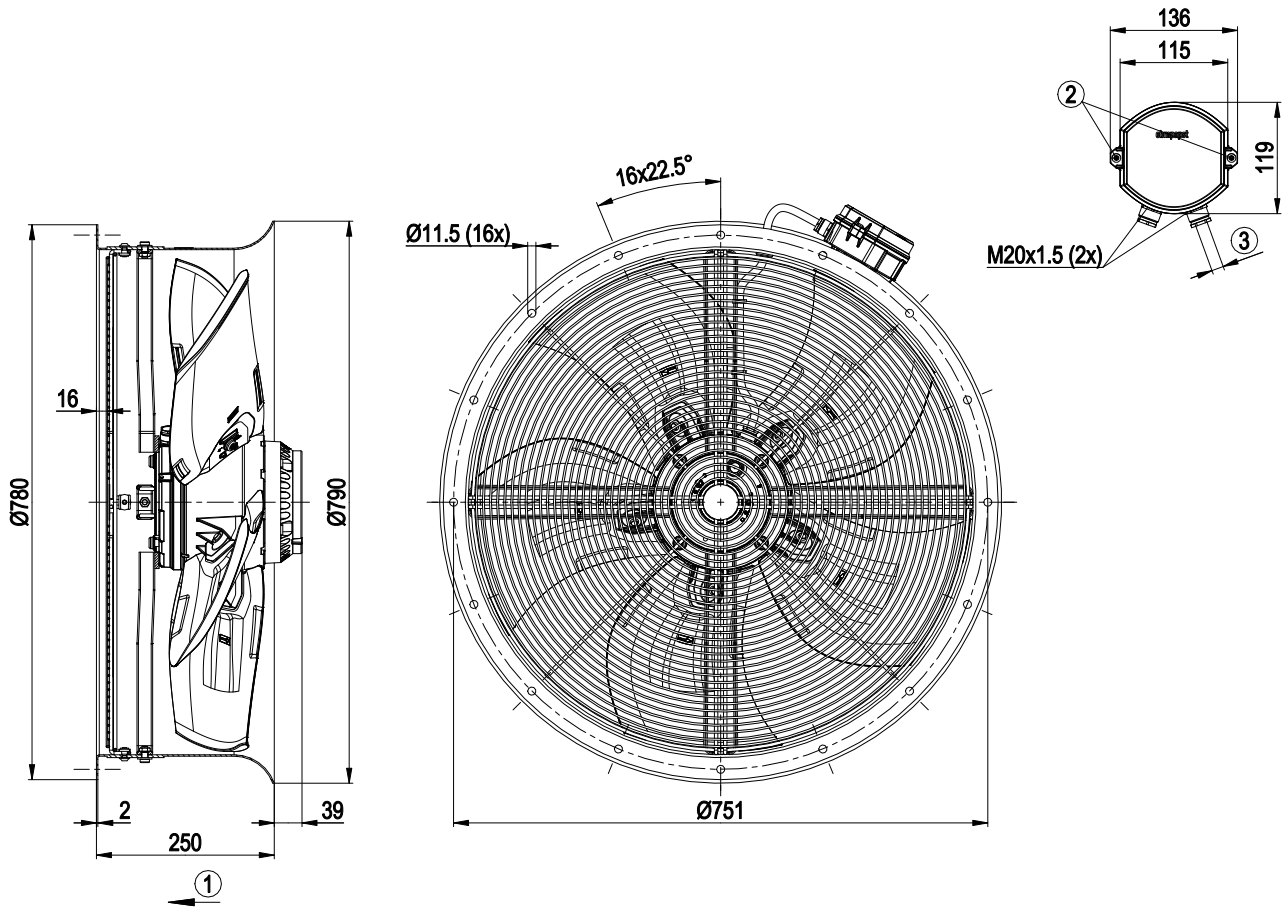

1	Airflow direction "V"
2	Tightening torque 3.5 ± 0.5 Nm
3	Cable diameter min. 7 mm, max. 14 mm, tightening torque 2 ± 0.3 Nm



AC axial fan

sickle-shaped blades (S series)

Duct fan, for rail applications

Connection diagram

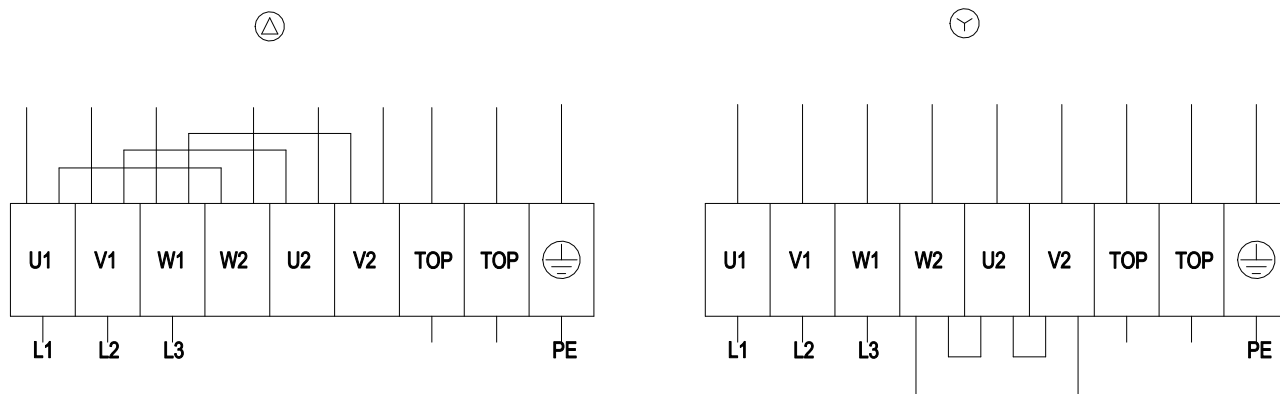

Δ	Delta connection	Y	Star connection	L1	= U1 = black
L2	= V1 = blue	L3	= W1 = brown	W2	yellow
U2	green	V2	white	TOP	2x gray
PE	green/yellow				

