

W4D630-GF03-03 ebmpapst Datasheet

sales@fansco.com

www.fansco.com

## Nominal data

Type	W4D630-GF03-03				
Motor	M4D138-LA				
Phase		3~	3~	3~	3~
Nominal voltage	VAC	230	277	400	480
Wiring		$\Delta$	$\Delta$	Y	Y
Frequency	Hz	50	60	50	60
Method of obtaining data		ml	ml	ml	ml
Valid for approval/standard		CE	CE	CE	CE
Speed (rpm)	min <sup>-1</sup>	1405	1660	1405	1660
Power consumption	W	1720	2860	1720	2860
Current draw	A	6.67	8.18	3.86	4.73
Max. back pressure	Pa	220	310	220	310
Max. back pressure	in. wg	0.88	1.24	0.88	1.24
Min. ambient temperature	°C	-40	-40	-40	-40
Max. ambient temperature	°C	65	60	65	60
Starting current	A	27		27	

ml = Max. load · me = Max. efficiency · fa = Free air · cs = Customer specification · ce = Customer equipment  
Subject to change

## Data according to Commission Regulation (EU) 327/2011 (EN 17166)

		Actual	Req. 2015		
01 Overall efficiency $\eta_{es}$	%	35.4	35.2	09 Power consumption $P_e$	kW 1.73
02 Measurement category		A		09 Air flow $q_v$	m <sup>3</sup> /h 10845
03 Efficiency category		Static		09 Pressure increase $p_{fs}$	Pa 205
04 Efficiency grade N		40.2	40	10 Speed (rpm) n	min <sup>-1</sup> 1405
05 Variable speed drive		No		11 Specific ratio*	1.00

Data obtained at optimum efficiency level.  
The ErP data is determined using a motor-impeller combination in a standardized measurement setup.

\* Specific ratio =  $1 + p_{fs} / 100\,000\text{ Pa}$ 

LU-201248



# AC axial fan - HyBlade

sickle-shaped blades (S series)

with square full nozzle

## Technical description

Weight	38.9 kg
Size	630 mm
Motor size	138
Rotor surface	Cast in aluminum
Terminal box material	PP plastic
Blade material	Sheet aluminum insert, sprayed with PP plastic
Fan housing material	Sheet steel, galvanized and coated with black plastic (RAL 9005)
Guard grille material	Steel, coated with black plastic (RAL 9005)
Number of blades	5
Blade pitch	-10°
Airflow direction	V
Direction of rotation	Clockwise, viewed toward rotor
Degree of protection	IP54
Insulation class	"F"
Moisture (F) / Environmental (H) protection class	H2
Ambient temperature note	Occasional start-up at temperatures between -40°C and -25°C is permitted. For continuous operation at ambient temperatures below -25°C (such as refrigeration applications), use must be made of a fan design with special low-temperature bearings.
Max. permitted ambient temp. for motor (transport/storage)	+80 °C
Min. permitted ambient temp. for motor (transport/storage)	-40 °C
Installation position	Any
Condensation drainage holes	On rotor and stator sides
Mode	S1
Motor bearing	Ball bearing
Touch current according to IEC 60990 (measuring circuit Fig. 4, TN system)	<= 3.5 mA
Electrical hookup	Terminal box
Motor protection	Thermal overload protector (TOP) with basic insulation
With cable	Axial
Protection class	I (with customer connection of protective earth)
Conformity with standards	EN 60034-1 (2010); CE
Approval	CSA C22.2 No. 100; EAC; UL 1004-1



# AC axial fan - HyBlade

sickle-shaped blades (S series)

with square full nozzle

## Product drawing

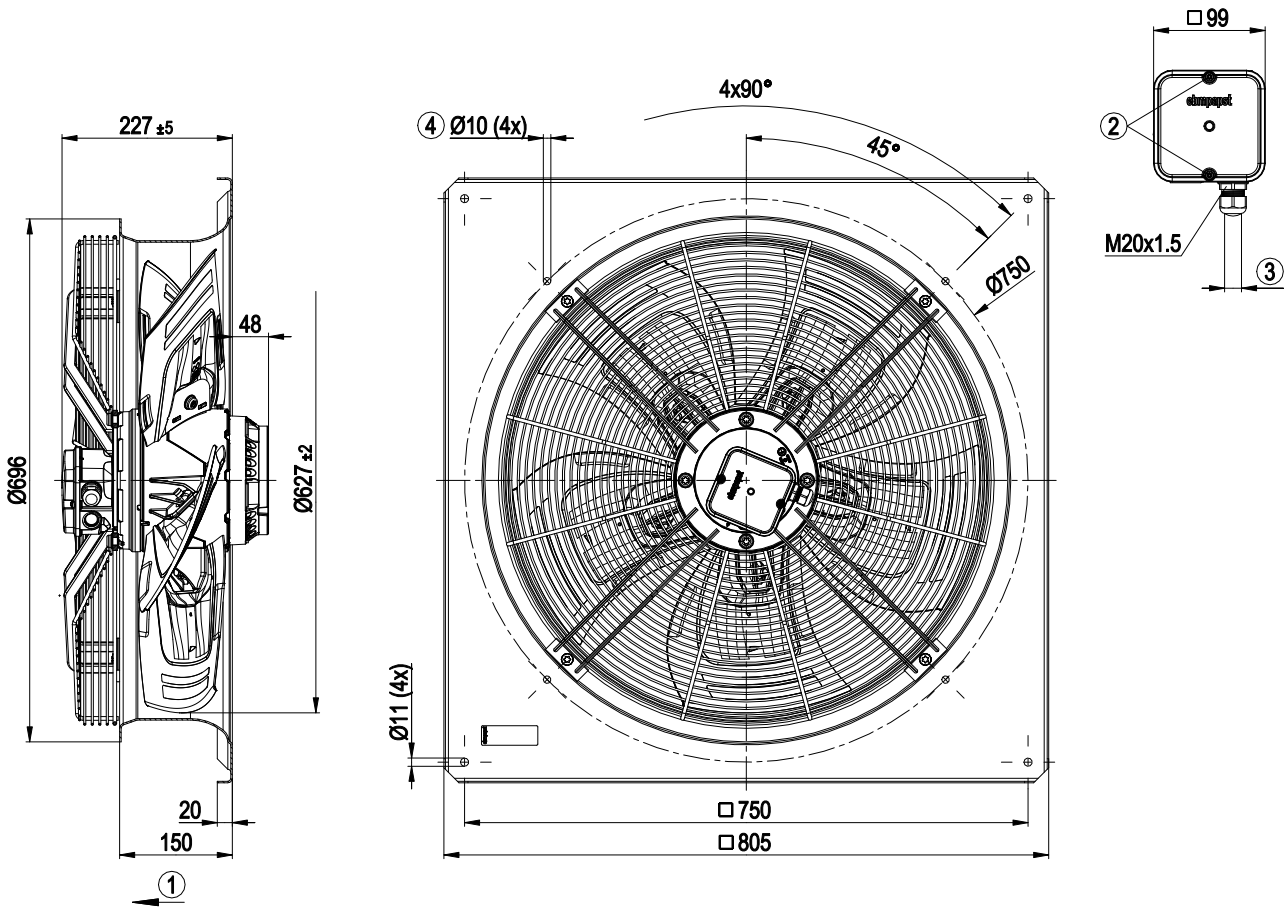

1	Direction of air flow "V"
2	Tightening torque 1.5 ± 0.2 Nm
3	Cable diameter min. 7 mm, max. 14 mm, tightening torque 2 ± 0.3 Nm
4	Attachment holes for FlowGrid (63000-2-2957 not included in scope of delivery)



# AC axial fan - HyBlade

sickle-shaped blades (S series)

with square full nozzle

## Connection diagram

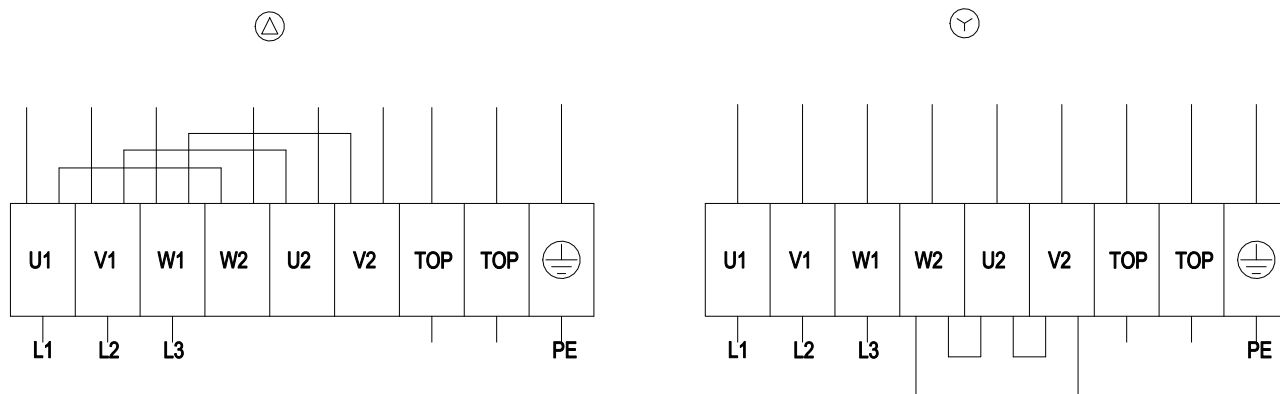

Δ	Delta connection	Y	Star connection	L1	= U1 = black
L2	= V1 = blue	L3	= W1 = brown	W2	yellow
U2	green	V2	white	TOP	2x gray
PE	green/yellow				

# AC axial fan - HyBlade

sickle-shaped blades (S series)

with square full nozzle

## Curves: Air performance 50 Hz

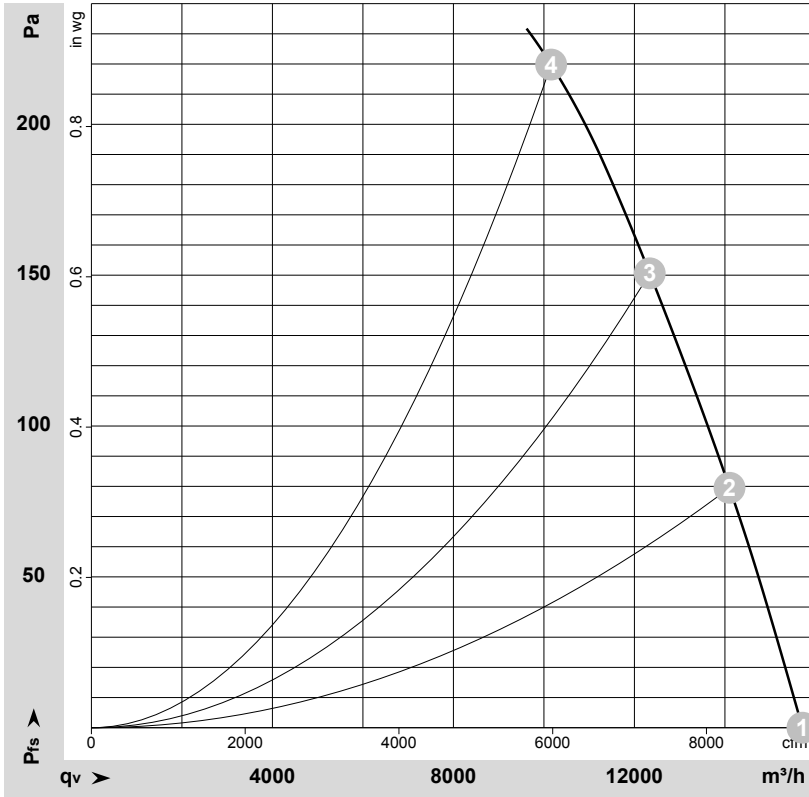

$\rho = 1.15 \text{ kg/m}^3 \pm 2 \%$

Measurement: LU-121453-1

Air performance measured according to ISO 5801 installation category A. For detailed information on the measurement setup, contact ebm-papst. Intake sound level: Sound power level according to ISO 13347 / sound pressure level measured at 1 m distance from fan axis. The values given are valid under the specified measuring conditions and may vary due to conditions of installation. For deviations from the standard configuration, the parameters have to be checked on the installed unit.

## Measured values

	Wired	U	f	n	P <sub>e</sub>	I	LpA <sub>in</sub>	LwA <sub>in</sub>	LwA <sub>out</sub>	q <sub>v</sub>	p <sub>fs</sub>	q <sub>v</sub>	p <sub>fs</sub>
		V	Hz	min <sup>-1</sup>	W	A	dB(A)	dB(A)	dB(A)	m <sup>3</sup> /h	Pa	cfm	in. wg
1	Y	400	50	1445	1147	3.33	71	78	78	15715	0	9250	0.00
2	Y	400	50	1430	1367	3.50	69	76	76	14100	80	8300	0.32
3	Y	400	50	1405	1720	3.86	72	78	78	12340	150	7260	0.60
4	Y	400	50	1405	1720	3.86	75	82	82	10160	220	5980	0.88

Wired = Wiring · U = Voltage · f = Frequency · n = Speed (rpm) · P<sub>e</sub> = Power consumption · I = Current draw · LpA<sub>in</sub> = Sound pressure level intake side · LwA<sub>in</sub> = Sound power level intake side  
 LwA<sub>out</sub> = Sound power level outlet side · q<sub>v</sub> = Air flow · p<sub>fs</sub> = Pressure increase



# AC axial fan - HyBlade

sickle-shaped blades (S series)

with square full nozzle

## Curves: Air performance 60 Hz

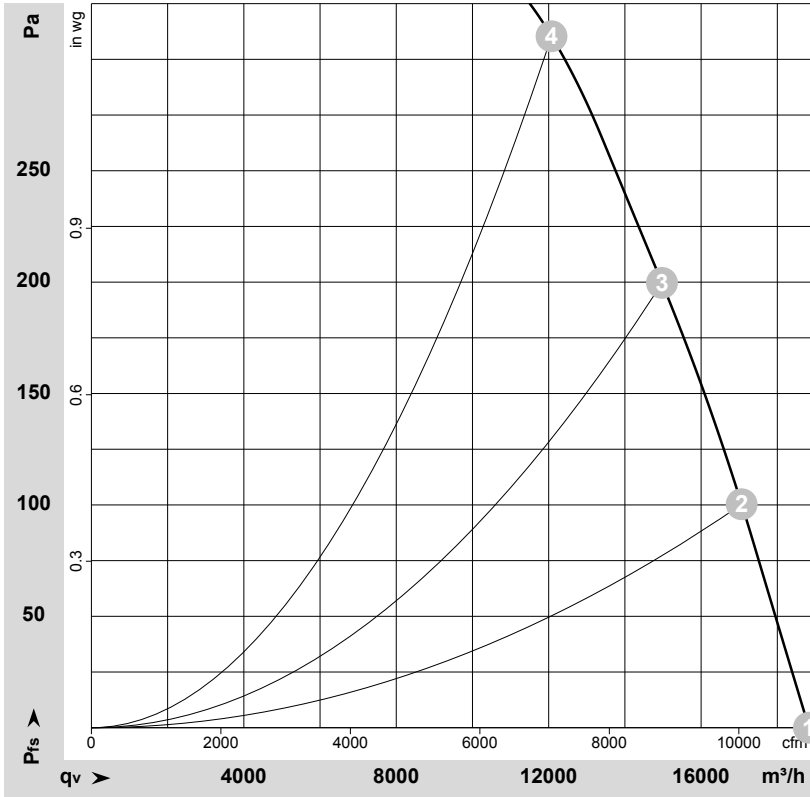

$\rho = 1.15 \text{ kg/m}^3 \pm 2 \%$

Measurement: LU-121467-1

Air performance measured according to ISO 5801 installation category A. For detailed information on the measurement setup, contact ebmpapst. Intake sound level: Sound power level according to ISO 13347 / sound pressure level measured at 1 m distance from fan axis. The values given are valid under the specified measuring conditions and may vary due to conditions of installation. For deviations from the standard configuration, the parameters have to be checked on the installed unit.

## Measured values

	Wired	U	f	n	P <sub>e</sub>	I	LpA <sub>in</sub>	LwA <sub>in</sub>	LwA <sub>out</sub>	q <sub>v</sub>	p <sub>fs</sub>	q <sub>v</sub>	p <sub>fs</sub>
		V	Hz	min <sup>-1</sup>	W	A	dB(A)	dB(A)	dB(A)	m <sup>3</sup> /h	Pa	cfm	in. wg
1	Y	480	60	1715	1884	3.71	75	82	82	18830	0	11085	0.00
2	Y	480	60	1700	2224	4.03	73	80	80	17065	100	10045	0.40
3	Y	480	60	1680	2552	4.36	75	82	82	14975	200	8815	0.80
4	Y	480	60	1660	2860	4.73	80	87	86	12075	310	7105	1.24

Wired = Wiring · U = Voltage · f = Frequency · n = Speed (rpm) · P<sub>e</sub> = Power consumption · I = Current draw · LpA<sub>in</sub> = Sound pressure level intake side · LwA<sub>in</sub> = Sound power level intake side  
 LwA<sub>out</sub> = Sound power level outlet side · q<sub>v</sub> = Air flow · p<sub>fs</sub> = Pressure increase

