

W4D450-CU01-02 ebmpapst Datasheet

sales@fansco.com

www.fansco.com

Nominal data

Type	W4D450-CU01-02				
Motor	M4D094-EA				
Phase		3~	3~	3~	3~
Nominal voltage	VAC	400	400	400	400
Wiring		Δ	Y	Δ	Y
Frequency	Hz	50	50	60	60
Method of obtaining data		ml	ml	ml	ml
Valid for approval/standard		CE	CE	CE	CE
Speed (rpm)	min ⁻¹	1250	875	1360	860
Power consumption	W	340	200	415	205
Current draw	A	0.61	0.33	0.70	0.35
Max. back pressure	Pa	120	60	85	35
Max. back pressure	in. wg	0.48	0.24	0.34	0.14
Min. ambient temperature	°C	-40	-40	-40	-40
Max. ambient temperature	°C	60	60	50	50
Starting current	A	1.7	0.55	1.57	0.51

ml = Max. load · me = Max. efficiency · fa = Free air · cs = Customer specification · ce = Customer equipment
Subject to change

Data according to Commission Regulation (EU) 327/2011 (EN 17166)

		Actual	Req. 2015			
01 Overall efficiency η_{es}	%	30.3	30.3	09 Power consumption P_e	kW	0.28
02 Measurement category		A		09 Air flow q_v	m ³ /h	3295
03 Efficiency category		Static		09 Pressure increase p_{fs}	Pa	99
04 Efficiency grade N		40	40	10 Speed (rpm) n	min ⁻¹	1275
05 Variable speed drive		No		11 Specific ratio*		1.00

Data obtained at optimum efficiency level.

* Specific ratio = $1 + p_{fs} / 100\,000\text{ Pa}$

LU-200510

The efficiency values displayed for achieving conformity with the Ecodesign Regulation EU 327/2011 has been reached with defined air duct components (e.g. inlet rings).
The dimensions must be requested from ebm-papst. If other air conduction geometries are used on the installation side, the ebm-papst evaluation loses its validity/the conformity must be confirmed again.
The product does not fall within the scope of Regulation (EU) 2019/1781 due to the exception specified in Article 2 (2a) (motors completely integrated into a product).

AC axial fan

sickle-shaped blades (S series)

with round full nozzle

Technical description

Weight	9.4 kg
Size	450 mm
Motor size	94
Rotor surface	Painted black
Terminal box material	PP plastic
Blade material	Press-fitted sheet steel blank, sprayed with PP plastic
Fan housing material	Sheet steel, galvanized and coated with black plastic (RAL 9005)
Guard grille material	Steel, coated with black plastic (RAL 9005)
Number of blades	5
Airflow direction	A
Direction of rotation	Clockwise, viewed toward rotor
Degree of protection	IP54
Insulation class	"F"
Moisture (F) / Environmental (H) protection class	H2
Ambient temperature note	Occasional start-up at temperatures between -40°C and -25°C is permitted. For continuous operation at ambient temperatures below -25°C (such as refrigeration applications), use must be made of a fan design with special low-temperature bearings.
Max. permitted ambient temp. for motor (transport/storage)	+80 °C
Min. permitted ambient temp. for motor (transport/storage)	-40 °C
Installation position	Shaft horizontal or rotor on bottom; rotor on top on request
Condensation drainage holes	On rotor side
Mode	S1
Motor bearing	Ball bearing
Touch current according to IEC 60990 (measuring circuit Fig. 4, TN system)	<= 3.5 mA
Electrical hookup	Terminal box
Motor protection	Thermal overload protector (TOP) with basic insulation
Protection class	I (with customer connection of protective earth)
Conformity with standards	EN 60034-1 (2010); CE
Approval	CCC; EAC



AC axial fan

sickle-shaped blades (S series)
with round full nozzle

Product drawing

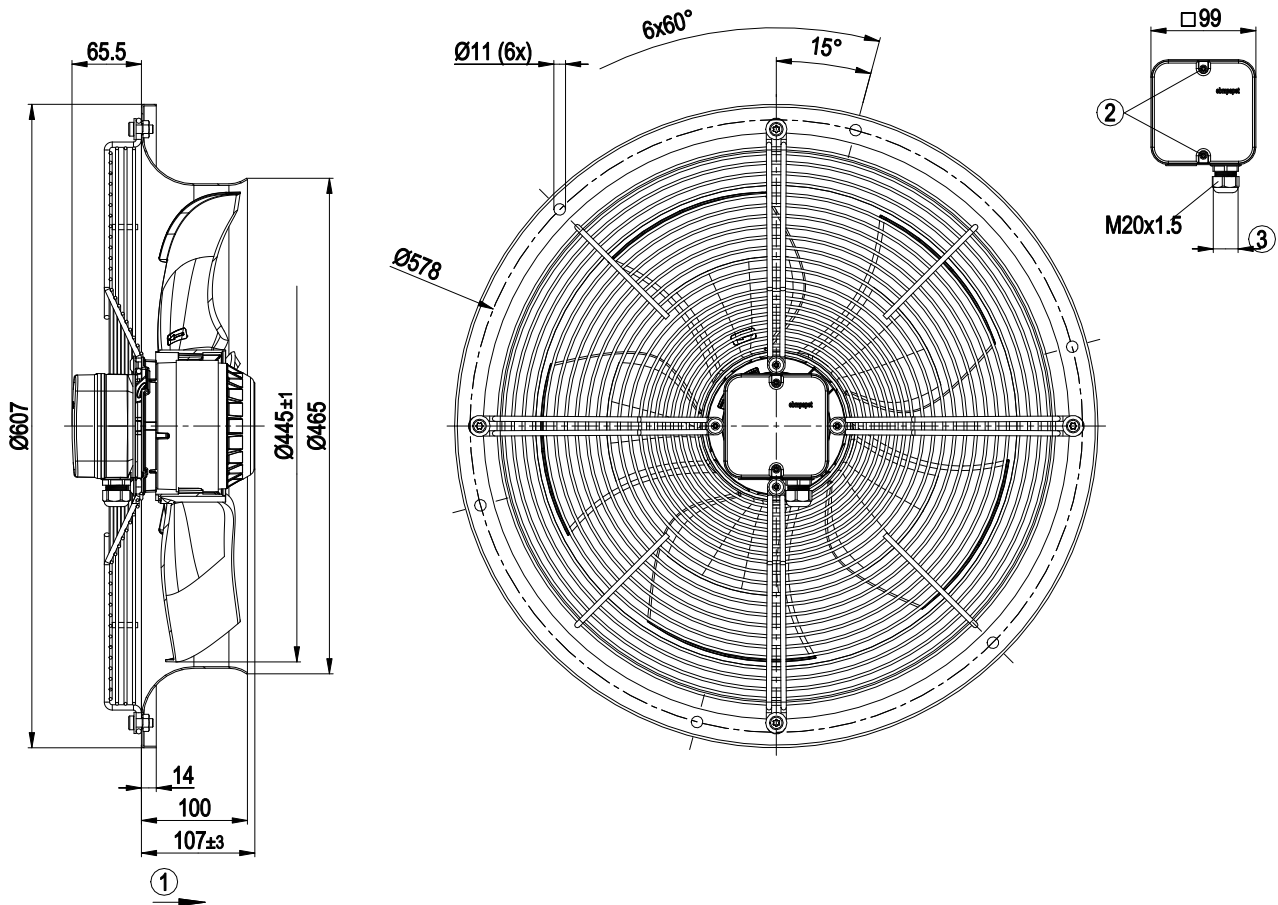

1	Direction of air flow "A"
2	Tightening torque 1.5 ± 0.2 Nm
3	Cable diameter min. 6 mm, max. 12 mm, tightening torque 2 ± 0.3 Nm



AC axial fan

sickle-shaped blades (S series)
with round full nozzle

Connection diagram

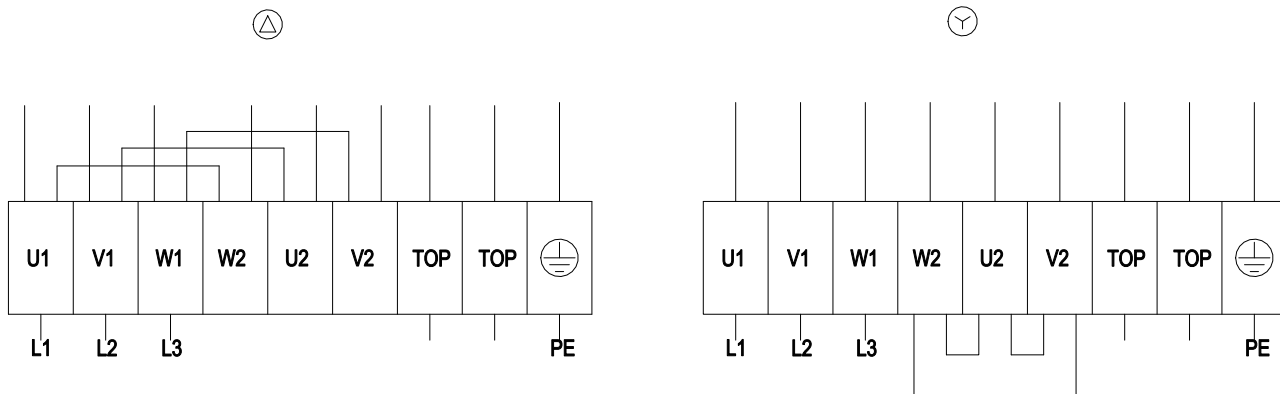

Δ	Delta connection	Y	Star connection	L1	= U1 = black
L2	= V1 = blue	L3	= W1 = brown	W2	yellow
U2	green	V2	white	TOP	2x gray
PE	green/yellow				



AC axial fan

sickle-shaped blades (S series)
with round full nozzle

Curves: Air performance 50 Hz

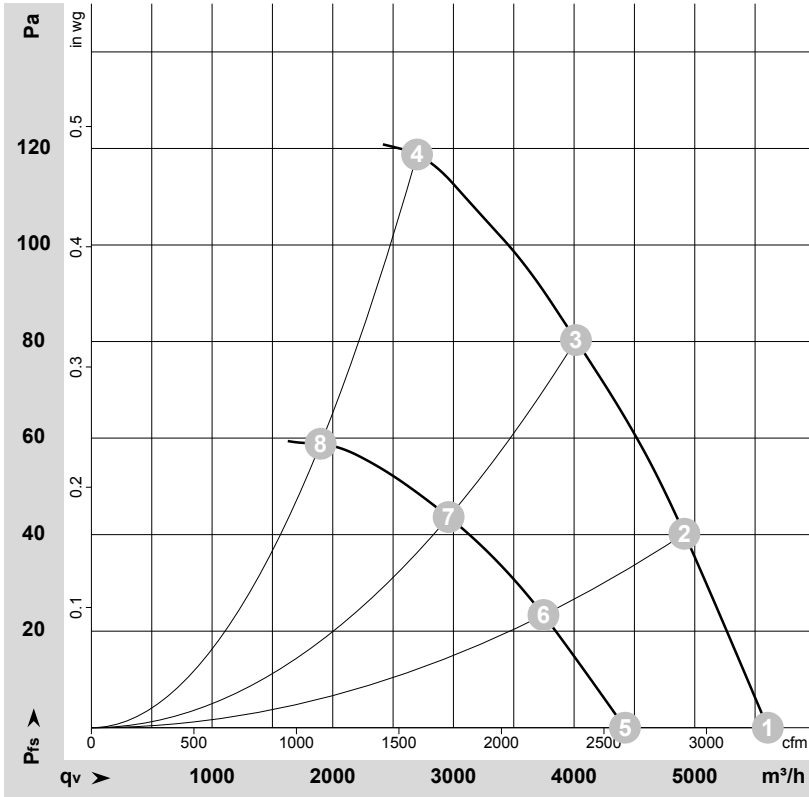

$\rho = 1.15 \text{ kg/m}^3 \pm 2 \%$

Measurement: LU-72632-1
Measurement: LU-72634-1

Air performance measured according to ISO 5801 installation category A. For detailed information on the measurement setup, contact ebm-papst. Intake sound level: Sound power level according to ISO 13347 / sound pressure level measured at 1 m distance from fan axis. The values given are valid under the specified measuring conditions and may vary due to conditions of installation. For deviations from the standard configuration, the parameters have to be checked on the installed unit.

Measured values

	Wired	U	f	n	P _e	I	q _v	P _{fs}	q _v	P _{fs}
		V	Hz	min ⁻¹	W	A	m ³ /h	Pa	cfm	in. wg
1	Δ	400	50	1350	231	0.49	5605	0	3300	0.00
2	Δ	400	50	1320	264	0.53	4915	40	2890	0.16
3	Δ	400	50	1295	293	0.56	4015	80	2365	0.32
4	Δ	400	50	1250	340	0.61	2700	120	1590	0.48
5	Y	400	50	1070	160	0.27	4420	0	2605	0.00
6	Y	400	50	1015	173	0.29	3745	23	2205	0.09
7	Y	400	50	960	183	0.31	2960	44	1740	0.18
8	Y	400	50	875	200	0.33	1900	59	1120	0.24

Wired = Wiring · U = Voltage · f = Frequency · n = Speed (rpm) · P_e = Power consumption · I = Current draw · q_v = Air flow · P_{fs} = Pressure increase



AC axial fan

sickle-shaped blades (S series)
with round full nozzle

Curves: Air performance 60 Hz

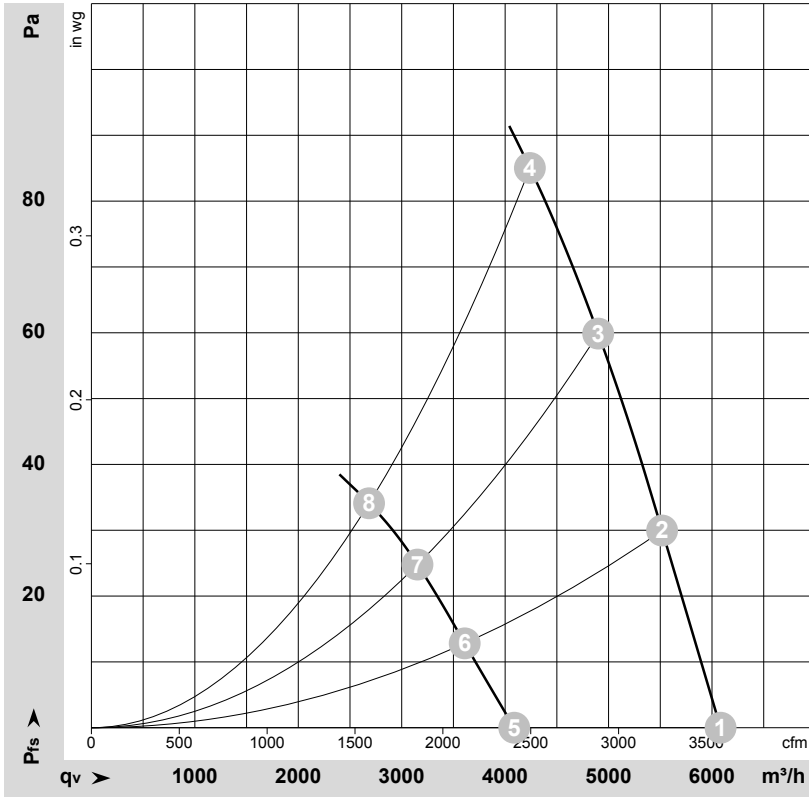

$\rho = 1.15 \text{ kg/m}^3 \pm 2 \%$

Measurement: LU-72642-1
Measurement: LU-72646-1

Air performance measured according to ISO 5801 installation category A. For detailed information on the measurement setup, contact ebm-papst. Intake sound level: Sound power level according to ISO 13347 / sound pressure level measured at 1 m distance from fan axis. The values given are valid under the specified measuring conditions and may vary due to conditions of installation. For deviations from the standard configuration, the parameters have to be checked on the installed unit.

Measured values

	Wired	U	f	n	P_e	I	q_v	P_{fs}	q_v	P_{fs}
		V	Hz	min^{-1}	W	A	m^3/h	Pa	cfm	in. wg
1	Δ	400	60	1455	334	0.57	6085	0	3580	0.00
2	Δ	400	60	1415	360	0.61	5520	30	3250	0.12
3	Δ	400	60	1380	384	0.64	4900	60	2885	0.24
4	Δ	400	60	1360	415	0.70	4240	85	2495	0.34
5	Y	400	60	990	187	0.31	4090	0	2405	0.00
6	Y	400	60	935	192	0.32	3610	13	2125	0.05
7	Y	400	60	895	197	0.33	3150	25	1855	0.10
8	Y	400	60	860	205	0.35	2685	34	1580	0.14

Wired = Wiring · U = Voltage · f = Frequency · n = Speed (rpm) · P_e = Power consumption · I = Current draw · q_v = Air flow · P_{fs} = Pressure increase

