

AC axial panel fan - HyBlade

sickle-shaped blades (S series)

with round full nozzle

W4D450-CO14-01 ebmpapst Datasheet

sales@fansco.com

www.fansco.com

Nominal data

Type	W4D450-CO14-01						
Motor	M4D094-HA						
Phase		3~	3~	3~	3~	3~	3~
Nominal voltage	VAC	400	400	400	400	460	460
Wiring		Δ	Y	Δ	Y	Δ	Y
Frequency	Hz	50	50	60	60	60	60
Method of obtaining data		ml	ml	ml	ml	ml	ml
Valid for approval/standard		-	-	-	-	-	-
Speed (rpm)	min ⁻¹	1360	1110	1510	1060	1580	1190
Power consumption	W	480	340	690	400	740	490
Current draw	A	0.98	0.58	1.2	0.72	1.17	0.74
Max. back pressure	Pa	140	90	145	70	155	90
Max. back pressure	in. wg	0.56	0.36	0.58	0.28	0.62	0.36
Min. ambient temperature	°C	-40	-40	-40	-40	-40	-40
Max. ambient temperature	°C	65	65	50	50	50	50
Starting current	A	3.9	1.3	3.5	1.2		

ml = Max. load · me = Max. efficiency · fa = Free air · cs = Customer specification · ce = Customer equipment
Subject to change

AC axial panel fan - HyBlade

sickle-shaped blades (S series)

with round full nozzle

Technical description

Weight	12.5 kg
Size	450 mm
Motor size	94
Rotor surface	Painted black
Terminal box material	PP plastic
Blade material	Press-fitted sheet steel blank, sprayed with PP plastic
Fan housing material	Sheet steel, galvanized and coated with black plastic (RAL 9005)
Guard grille material	Steel, coated with black plastic (RAL 9005)
Number of blades	5
Airflow direction	V
Direction of rotation	Counterclockwise, viewed toward rotor
Degree of protection	IP54
Insulation class	"F"
Moisture (F) / Environmental (H) protection class	H2 = Wet – direct exposure to water
Ambient temperature note	Occasional start-up at temperatures between -40°C and -25°C is permitted. For continuous operation at ambient temperatures below -25°C (such as refrigeration applications), use must be made of a fan design with special low-temperature bearings.
Max. permitted ambient temp. for motor (transport/storage)	+80 °C
Min. permitted ambient temp. for motor (transport/storage)	-40 °C
Installation position	Shaft horizontal or rotor on bottom; rotor on top on request
Condensation drainage holes	On rotor side
Mode	S1
Motor bearing	Ball bearing
Touch current according to IEC 60990 (measuring circuit Fig. 4, TN system)	<= 3.5 mA
Electrical hookup	Terminal box
Motor protection	Thermal switch auto reset, lead out, with basic insulation
Protection class assignment	I; If a protective earth is connected. The built-in component has several local protection class assignments. The final protection class is determined by the intended installation.
Conformity with standards	EN 60034-1 (2010)
Comment on CE	Commissioning not permitted in the European Economic Area
Approval	CCC; EAC

AC axial panel fan - HyBlade

sickle-shaped blades (S series)

with round full nozzle

Product drawing

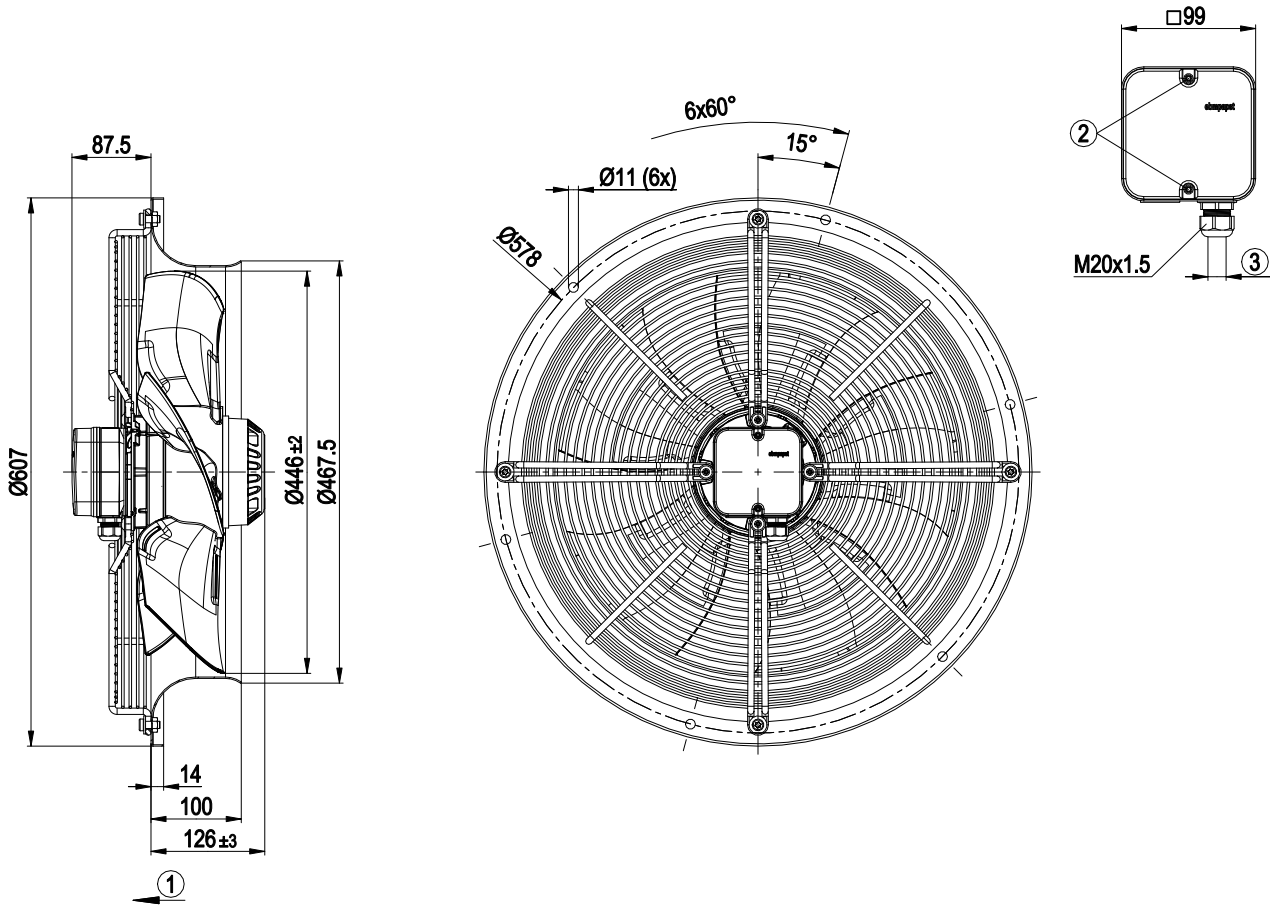

1	Direction of air flow "V"
2	Tightening torque 1.5 ± 0.2 Nm
3	Cable diameter min. 6 mm, max. 12 mm, tightening torque 2 ± 0.3 Nm

AC axial panel fan - HyBlade

sickle-shaped blades (S series)

with round full nozzle

Connection diagram

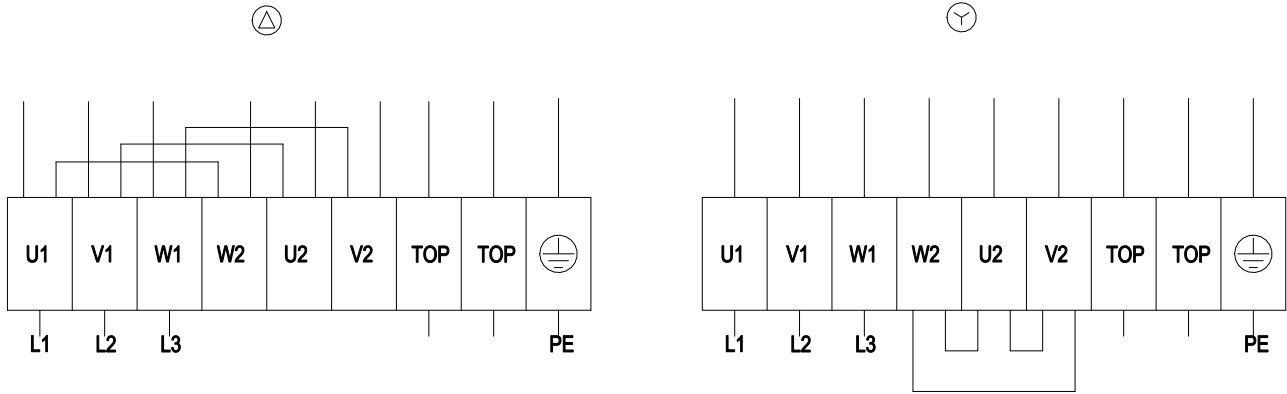

Δ	Delta connection	Y	Star connection	L1	= U1 = black
L2	= V1 = blue	L3	= W1 = brown	W2	yellow
U2	green	V2	white	TOP	2x gray
PE	green/yellow				

AC axial panel fan - HyBlade

sickle-shaped blades (S series)

with round full nozzle

Curves: Air performance 50 Hz

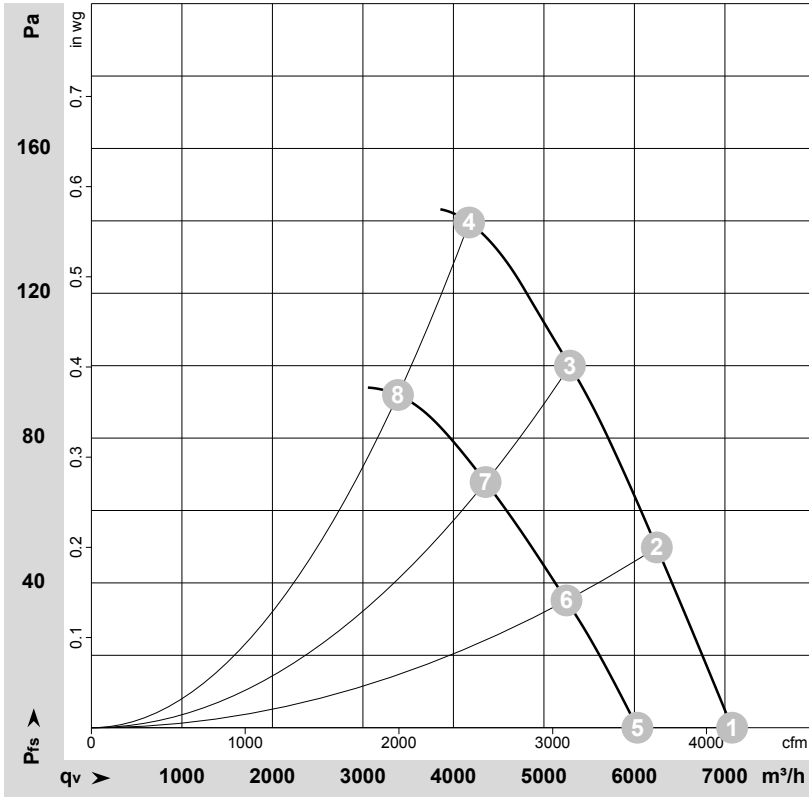

$\rho = 1.19 \text{ kg/m}^3 \pm 2 \%$

Measurement: LU-107893-1
Date: 2008-02-13
Housing: 64000-2-4037

Measurement: LU-107309-1
Date: 2008-01-22
Housing: 64000-2-4037

Air performance measured according to ISO 5801 installation category A. For detailed information on the measurement setup, contact ebm-papst. Intake sound level: Sound power level according to ISO 13347 / sound pressure level measured at 1 m distance from fan axis. The values given are valid under the specified measuring conditions and may vary due to conditions of installation. For deviations from the standard configuration, the parameters have to be checked on the installed unit.

Measured values

	Wired	U	f	n	P _e	I	LpA _{in}	LwA _{in}	LwA _{out}	q _v	p _{fs}	q _v	p _{fs}
		V	Hz	min ⁻¹	W	A	dB(A)	dB(A)	dB(A)	m ³ /h	Pa	cfm	in. wg
1	Δ	400	50	1400	386	0.88	65	71	72	7080	0	4165	0.00
2	Δ	400	50	1385	423	0.91	62	68	69	6250	50	3675	0.20
3	Δ	400	50	1370	456	0.95	61	68	68	5290	100	3110	0.40
4	Δ	400	50	1360	480	0.98	63	69	70	4175	140	2455	0.56
5	Y	400	50	1195	285	0.49				6035	0	3550	0.00
6	Y	400	50	1155	309	0.52				5250	35	3090	0.14
7	Y	400	50	1130	328	0.55				4355	68	2565	0.27
8	Y	400	50	1110	340	0.58				3385	92	1995	0.37

Wired = Wiring · U = Voltage · f = Frequency · n = Speed (rpm) · P_e = Power consumption · I = Current draw · LpA_{in} = Sound pressure level intake side · LwA_{in} = Sound power level intake side
LwA_{out} = Sound power level outlet side · q_v = Air flow · p_{fs} = Pressure increase

AC axial panel fan - HyBlade

sickle-shaped blades (S series)

with round full nozzle

Curves: Air performance 60 Hz

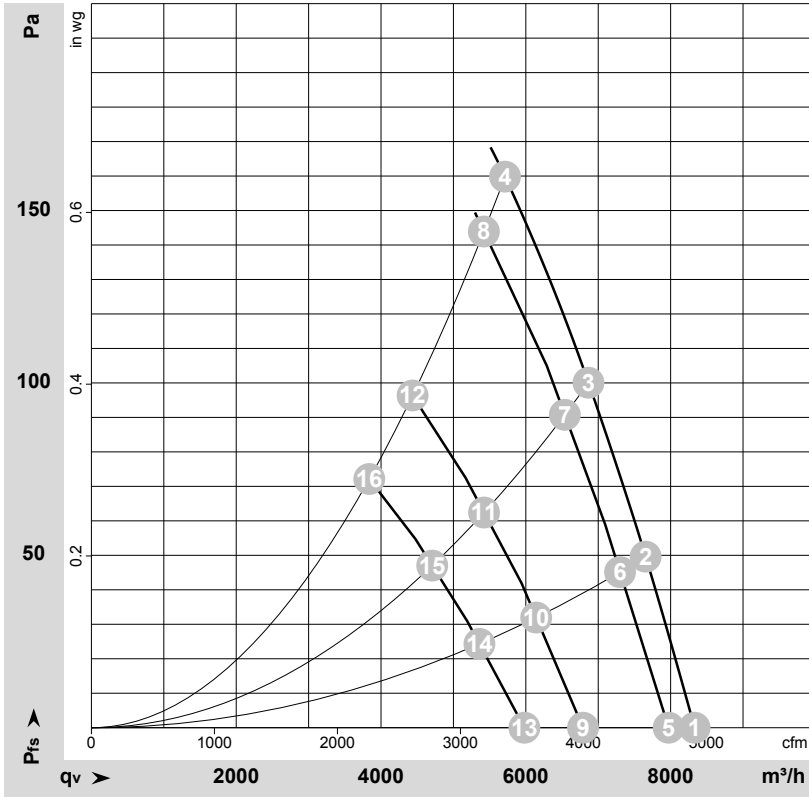

$$\rho = 1.19 \text{ kg/m}^3 \pm 2 \%$$

Measurement: LU-107898-1
Date: 2008-02-13
Housing: 64000-2-4037

Measurement: LU-108207-1
Date: 2008-02-13
Housing: 64000-2-4037

Measurement: LU-108205-1
Date: 2008-02-13
Housing: 64000-2-4037

Measurement: LU-108206-1
Date: 2008-02-13
Housing: 64000-2-4037

Air performance measured according to ISO 5801 installation category A. For detailed information on the measurement setup, contact ebm-papst. Intake sound level: Sound power level according to ISO 13347 / sound pressure level measured at 1 m distance from fan axis. The values given are valid under the specified measuring conditions and may vary due to conditions of installation. For deviations from the standard configuration, the parameters have to be checked on the installed unit.

Measured values

	Wired	U	f	n	P _e	I	LpA _{in}	LwA _{in}	LwA _{out}	q _v	p _{fs}	q _v	p _{fs}
		V	Hz	min ⁻¹	W	A	dB(A)	dB(A)	dB(A)	m ³ /h	Pa	cfm	in. wg
1	Δ	480	60	1645	628	1.03	68	74	76	8330	0	4905	0.00
2	Δ	480	60	1630	674	1.08	66	72	74	7655	50	4505	0.20
3	Δ	480	60	1615	716	1.12	65	71	73	6865	100	4040	0.40
4	Δ	480	60	1600	760	1.17	65	72	72	5715	160	3365	0.64
5	Δ	400	60	1570	580	1.03	67	73	74	7975	0	4695	0.00
6	Δ	400	60	1550	620	1.09	65	71	73	7300	45	4295	0.18
7	Δ	400	60	1530	657	1.15	64	70	71	6540	90	3850	0.36
8	Δ	400	60	1510	690	1.20	64	70	71	5420	145	3190	0.58
9	Y	480	60	1335	459	0.65	64	70	71	6790	0	3995	0.00
10	Y	480	60	1300	480	0.69	61	67	68	6145	32	3615	0.13
11	Y	480	60	1265	499	0.72	60	66	67	5425	62	3190	0.25
12	Y	480	60	1240	520	0.75	59	65	65	4435	96	2610	0.39
13	Y	400	60	1175	375	0.65	62	67	68	5980	0	3520	0.00
14	Y	400	60	1130	388	0.68	59	64	65	5360	24	3155	0.10
15	Y	400	60	1095	398	0.70	57	63	63	4705	47	2770	0.19
16	Y	400	60	1060	400	0.72	56	62	62	3840	72	2260	0.29

Wired = Wiring · U = Voltage · f = Frequency · n = Speed (rpm) · P_e = Power consumption · I = Current draw · LpA_{in} = Sound pressure level intake side · LwA_{in} = Sound power level intake side
LwA_{out} = Sound power level outlet side · q_v = Air flow · p_{fs} = Pressure increase