

AC axial fan

sickle-shaped blades (S series)

Fan housing with guard grille

W4D250-CH40-01 ebmpapst Datasheet

sales@fansco.com

www.fansco.com

Nominal data

Type	W4D250-CH40-01				
Motor	M4D068-CF				
Phase		3~	3~	3~	3~
Nominal voltage	VAC	230	230	400	400
Wiring		Δ	Δ	Y	Y
Frequency	Hz	50	60	50	60
Method of obtaining data		fa	fa	fa	fa
Valid for approval/standard		CE	CE	CE	CE
Speed (rpm)	min ⁻¹	1400	1600	1400	1600
Power consumption	W	23	30	23	30
Current draw	A	0.10	0.10	0.06	0.06
Max. back pressure	Pa	70	80	70	80
Max. back pressure	in. wg	0.28	0.32	0.28	0.32
Min. ambient temperature	°C	-25	-25	-25	-25
Max. ambient temperature	°C	90	90	90	90

ml = Max. load · me = Max. efficiency · fa = Free air · cs = Customer specification · ce = Customer equipment

Subject to change



AC axial fan

sickle-shaped blades (S series)

Fan housing with guard grille

Technical description

Weight	3 kg
Size	250 mm
Motor size	68
Rotor surface	Painted black
Blade material	Sheet steel, painted black
Fan housing material	Sheet steel, galvanized and coated with black plastic (RAL 9005)
Guard grille material	Steel, coated with black plastic (RAL 9005)
Number of blades	7
Airflow direction	V
Direction of rotation	Counterclockwise, viewed toward rotor
Degree of protection	IP44; installation- and position-dependent as per EN 60034-5
Insulation class	"B"
Moisture (F) / Environmental (H) protection class	H1+; F5
Max. permitted ambient temp. for motor (transport/storage)	+ 80 °C
Min. permitted ambient temp. for motor (transport/storage)	- 40 °C
Installation position	Shaft horizontal or rotor on bottom; rotor on top on request
Condensation drainage holes	On rotor side
Mode	S1
Motor bearing	Ball bearing
Touch current according to IEC 60990 (measuring circuit Fig. 4, TN system)	< 0.75 mA
With cable	Lateral
Protection class	I (with customer connection of protective earth)
Conformity with standards	EN 60335-1, motor does not have factory-installed overheating protection; CE
Approval	EAC



AC axial fan

sickle-shaped blades (S series)

Fan housing with guard grille

Product drawing

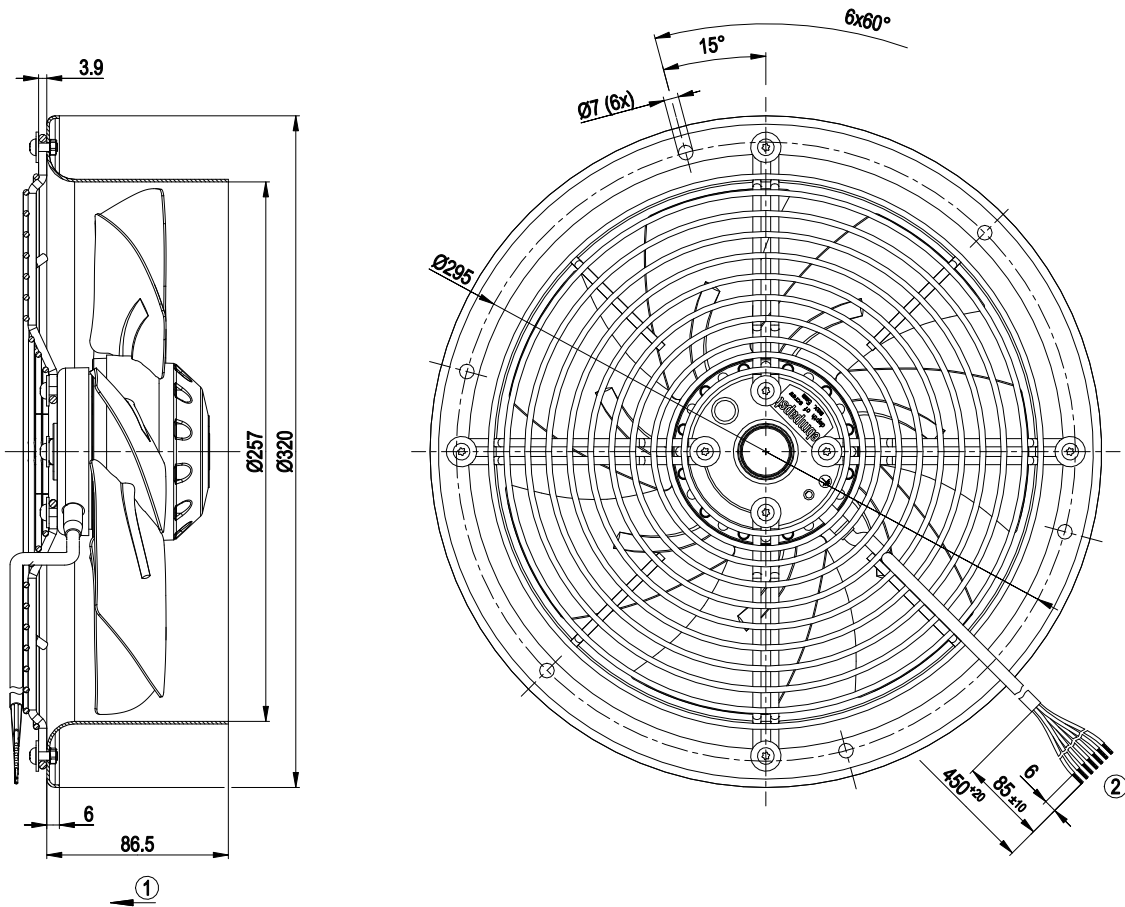

- | | |
|---|-------------------------------------|
| 1 | Direction of air flow "V" |
| 2 | Cable PFA AWG20, 7x crimped splices |



AC axial fan

sickle-shaped blades (S series)

Fan housing with guard grille

Connection diagram

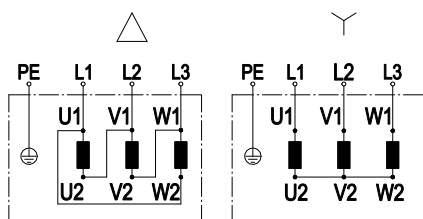

Change of rotation direction by reversing two phases

	Three-phase motor	Δ	Delta connection	Y	Star connection
L1	= U1 = black	L2	= V1 = blue	L3	= W1 = brown
U2	green	V2	white	W2	yellow
PE	green/yellow				



AC axial fan

sickle-shaped blades (S series)

Fan housing with guard grille

Curves: Air performance 50 Hz

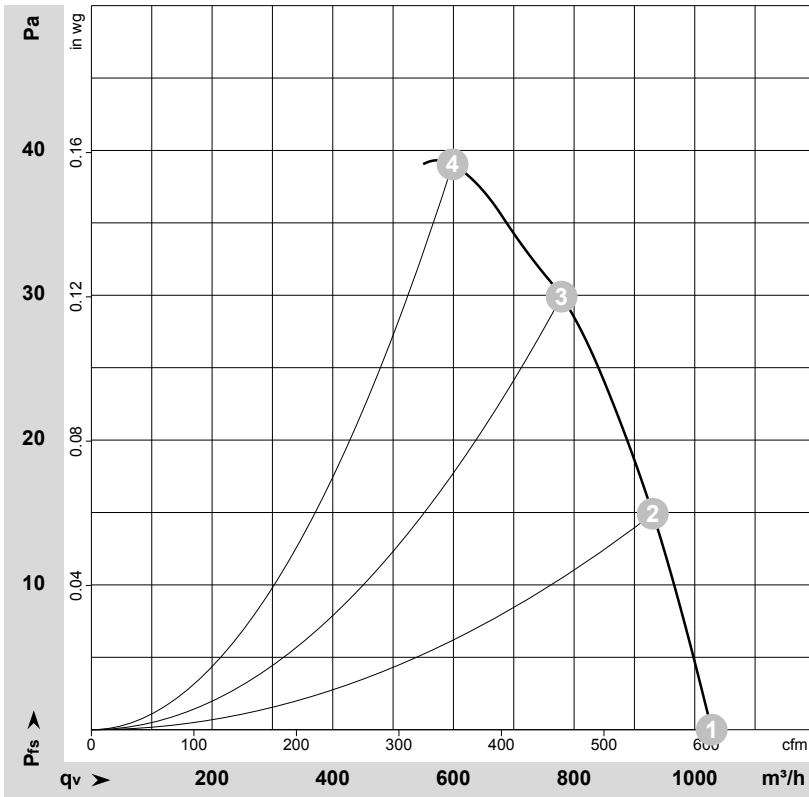

$\rho = 1.15 \text{ kg/m}^3 \pm 2 \%$

Measurement: LU-77947-1

Air performance measured according to ISO 5801 installation category A. For detailed information on the measurement setup, contact ebm-papst. Intake sound level: Sound power level according to ISO 13347 / sound pressure level measured at 1 m distance from fan axis. The values given are valid under the specified measuring conditions and may vary due to conditions of installation. For deviations from the standard configuration, the parameters have to be checked on the installed unit.

Measured values

	Wired	U	f	n	P _e	I	q _v	P _{fs}	q _v	P _{fs}
		V	Hz	min ⁻¹	W	A	m ³ /h	Pa	cfm	in. wg
1	Y	400	50	1400	23	0.06	1030	0	605	0.00
2	Y	400	50	1385	24	0.06	930	15	545	0.06
3	Y	400	50	1370	26	0.06	780	30	460	0.12
4	Y	400	50	1365	28	0.06	600	40	355	0.16

Wired = Wiring · U = Voltage · f = Frequency · n = Speed (rpm) · P_e = Power consumption · I = Current draw · q_v = Air flow · P_{fs} = Pressure increase



AC axial fan

sickle-shaped blades (S series)

Fan housing with guard grille

Curves: Air performance 60 Hz

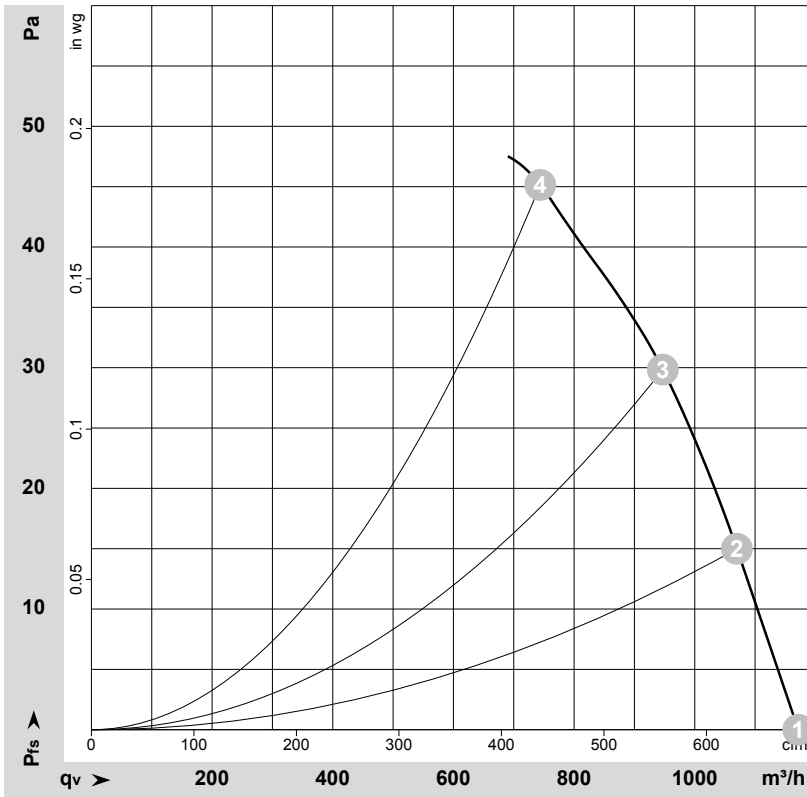

$\rho = 1.15 \text{ kg/m}^3 \pm 2 \%$

Measurement: LU-77948-1

Air performance measured according to ISO 5801 installation category A. For detailed information on the measurement setup, contact ebm-papst. Intake sound level: Sound power level according to ISO 13347 / sound pressure level measured at 1 m distance from fan axis. The values given are valid under the specified measuring conditions and may vary due to conditions of installation. For deviations from the standard configuration, the parameters have to be checked on the installed unit.

Measured values

	Wired	U	f	n	P_e	I	q_v	P_{fs}	q_v	P_{fs}
		V	Hz	min^{-1}	W	A	m^3/h	Pa	cfm	in. wg
1	Y	400	60	1600	30	0.06	1170	0	690	0.00
2	Y	400	60	1570	32	0.06	1070	15	630	0.06
3	Y	400	60	1545	35	0.06	945	30	555	0.12
4	Y	400	60	1515	38	0.07	745	45	440	0.18

Wired = Wiring · U = Voltage · f = Frequency · n = Speed (rpm) · P_e = Power consumption · I = Current draw · q_v = Air flow · P_{fs} = Pressure increase

