

EC axial fan - HyBlade

sickle-shaped blades (S series)

round full nozzle with diffuser

W3GZ50-EC04-01 ebmpapst Datasheet

sales@fansco.com

www.fansco.com

Limited partnership · Headquarters Muldingen

Amtsgericht (court of registration) Stuttgart · HRA 590344

General partner Elektrobau Muldingen GmbH · Headquarters Muldingen

Amtsgericht (court of registration) Stuttgart · HRB 590142



Nominal data

Type	W3GZ50-EC04-01	
Motor	M3G200-QA	
Phase		3~
Nominal voltage	VAC	400
Nominal voltage range	VAC	380 .. 480
Frequency	Hz	50/60
Method of obtaining data		ml
Status		prelim.
Speed	min ⁻¹	690
Power consumption	W	4900
Current draw	A	7.5
Max. back pressure	Pa	210
Min. ambient temperature	°C	-25
Max. ambient temperature	°C	70

ml = Max. load · me = Max. efficiency · fa = Free air · cs = Customer specification · ce = Customer equipment
 Subject to change

Data according to ErP Directive

		Actual	Req. 2015		
01 Overall efficiency η_{es}	%	51.1	37.9	09 Power consumption P_{ed}	kW 4.61
02 Measurement category		A		09 Air flow q_v	m ³ /h 45235
03 Efficiency category		Static		09 Pressure increase p_{fs}	Pa 180
04 Efficiency grade N		53.2	40	10 Speed n	min ⁻¹ 700
05 Variable speed drive		Yes		11 Specific ratio*	1.00

Data obtained at optimum efficiency level.
 The ErP data is determined using a motor-impeller combination in a standardized measurement setup.

* Specific ratio = $1 + p_s / 100\,000\text{ Pa}$

LU-152869



EC axial fan - HyBlade

sickle-shaped blades (S series)

round full nozzle with diffuser

Technical description

Weight	193 kg
Fan size	1250 mm
Rotor surface	Painted black
Terminal box material	PC plastic
Electronics housing material	Die-cast aluminum, painted black
Blade material	Die-cast aluminum
Support ring material	Steel, coated with black plastic (RAL 9005)
Fan housing material	Sheet steel, galvanized and coated with black plastic (RAL 9005)
Guard grille material	Steel, coated with black plastic (RAL 9005)
Outer diffuser material	Sheet steel, galvanized and coated with black plastic (RAL 9005)
Internal diffuser material including cover	Sheet steel, galvanized and coated with black plastic (RAL 9005)
Number of blades	5
Blade pitch	0°
Airflow direction	"V"
Direction of rotation	Clockwise, viewed toward rotor
Degree of protection	IP54
Insulation class	"F"
Moisture (F) / Environmental (H) protection class	H2
Max. permitted ambient temp. for motor (transport/storage)	+ 80 °C
Min. permitted ambient temp. for motor (transport/storage)	- 40 °C
Installation position	Shaft horizontal or rotor on bottom; rotor on top on request
Condensation drainage holes	On rotor side
Mode	S1
Motor bearing	Ball bearing
Technical features	<ul style="list-style-type: none"> - Output 10 VDC, max. 10 mA - Output 20 VDC, max. 50 mA - Output for slave 0-10 V - Input for sensor 0-10 V or 4-20 mA - External 24 V input (parameter setting) - External release input - Alarm relay - Integrated PID controller - Motor current limitation - PFC, passive - RS-485 MODBUS-RTU - Soft start - EEPROM write cycles: 100,000 maximum - Control input 0-10 VDC / PWM - Control interface with SELV potential safely disconnected from the mains - Thermal overload protection for electronics/motor - Line undervoltage / phase failure detection
Touch current according to IEC 60990 (measuring circuit Fig. 4, TN system)	<= 3.5 mA
Electrical hookup	Via terminal box



W3GZ50-EC04-01

EC axial fan - HyBlade

sickle-shaped blades (S series)

round full nozzle with diffuser

Motor protection	Reverse polarity and locked-rotor protection
Protection class	I (with customer connection of protective earth)
Conformity with standards	EN 61800-5-1; CE
Approval	C22.2 No.77 + CAN/CSA-E60730-1; EAC; UL 1004-7 + 60730



EC axial fan - HyBlade

sickle-shaped blades (S series)

round full nozzle with diffuser

Product drawing

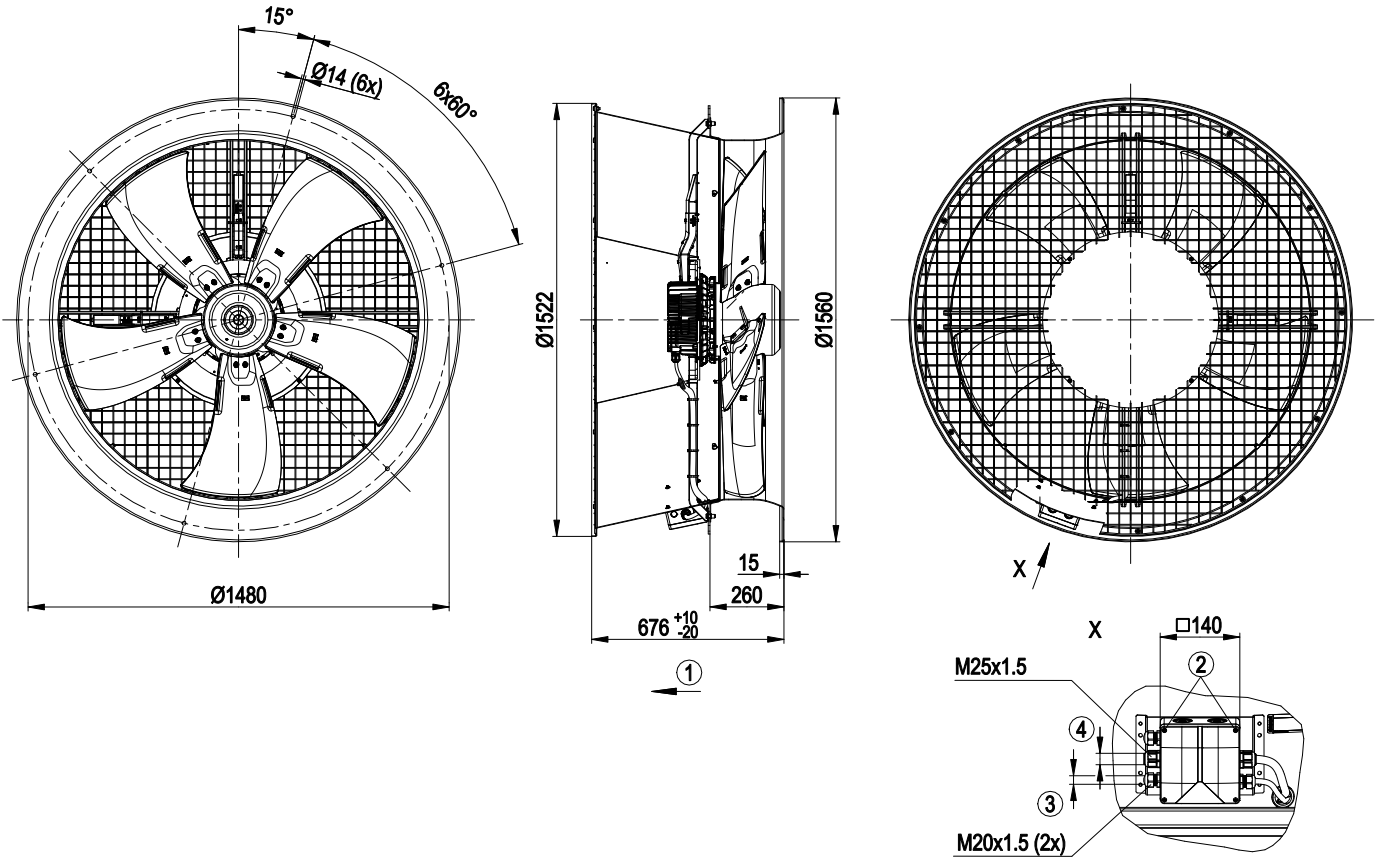

1	Direction of air flow "V"
2	Tightening torque 1.7 ± 0.2 Nm
3	Cable diameter min. 6 mm, max. 12 mm, tightening torque 4 ± 0.6 Nm
4	Cable diameter min. 9 mm, max. 16 mm, tightening torque 4 ± 0.6 Nm



EC axial fan - HyBlade

sickle-shaped blades (S series)

round full nozzle with diffuser

Connection diagram

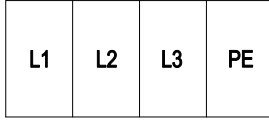

KL 1

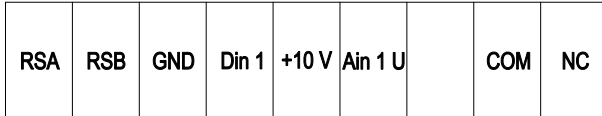

KL 2

No.	Conn.	Designation	Function/assignment
KL 1		L1	Supply connection, power supply 3-phase 380-480 VAC, 50/60 Hz
KL 1		L2	Supply connection, power supply 3-phase 380-480 VAC, 50/60 Hz
KL 1		L3	Supply connection, power supply 3-phase 380-480 VAC, 50/60 Hz
KL 1		PE	Ground connection, PE connection
KL 2		RSA	Bus connection RS485, RSA, MODBUS-RTU; SELV
KL 2		RSB	Bus connection RS485, RSB, MODBUS-RTU; SELV
KL 2		GND	Reference ground for control interface; SELV
KL 2		Din1	Digital input 1 enable electronics, enable: pin open or applied voltage 5-50 VDC disable: bridge to GND or applied voltage < 1 VDC reset function: triggers software reset after a level change to < 1 V; SELV
KL 2		+ 10 V	Fixed voltage output 10 VDC, +10 V ±3%, max. 10 mA, short-circuit-proof power supply for external devices (e.g. pot); SELV
KL 2		Ain1 U	Analog input 1, set value: 0-10 V, Ri = 100 kΩ, adjustable curve; SELV
KL2		COM	Status relay, floating status contact; changeover contact; common connection; contact rating 250 VAC / max. 2 A (AC1) / min. 10 mA
KL2		NC	Status relay, floating status contact, break for failure



EC axial fan - HyBlade

sickle-shaped blades (S series)

round full nozzle with diffuser

Curves: Air performance 50 Hz

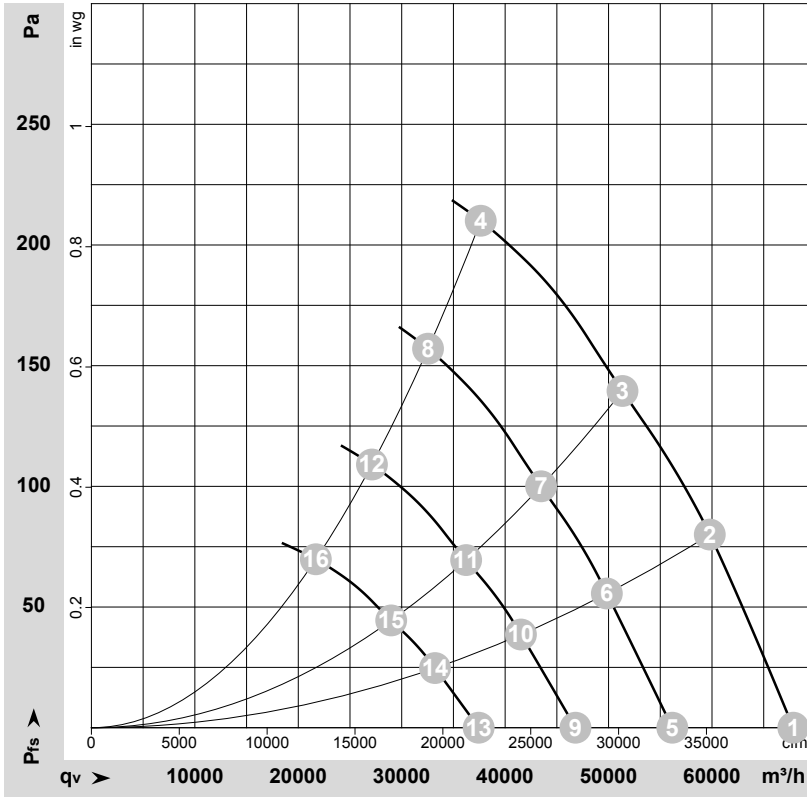

$\rho = 1.15 \text{ kg/m}^3 \pm 2 \%$

Measurement: LU-152869

Air performance measured according to ISO 5801 installation category A. For detailed information on the measurement setup, contact ebmpapst. Intake sound level: Sound power level according to ISO 13347 / sound pressure level measured at 1 m distance from fan axis. The values given are valid under the specified measuring conditions and may vary due to conditions of installation. For deviations from the standard configuration, the parameters have to be checked on the installed unit.

Measured values

	U	f	n	P _{ed}	I	LpA _{in}	LwA _{in}	LwA _{out}	qv	P _{fs}
	V	Hz	min ⁻¹	W	A	dB(A)	dB(A)	dB(A)	m ³ /h	Pa
1	400	50	720	3325	5.31	75	83	85	67860	0
2	400	50	720	4083	6.38	72	81	83	59785	80
3	400	50	710	4406	6.84	72	80	82	51345	140
4	400	50	690	4900	7.50	78	86	88	37640	210
5	400	50	600	1885	3.01	70	79	81	56160	0
6	400	50	600	2360	3.69	68	76	78	49835	56
7	400	50	600	2673	4.15	68	76	78	43475	100
8	400	50	600	3149	4.87	74	82	84	32545	157
9	400	50	500	1091	1.74	66	74	76	46800	0
10	400	50	500	1366	2.13	63	71	73	41530	39
11	400	50	500	1547	2.40	63	71	74	36230	69
12	400	50	500	1822	2.82	70	78	79	27120	109
13	400	50	400	558	0.89	60	68	70	37440	0
14	400	50	400	699	1.09	57	66	68	33220	25
15	400	50	400	792	1.23	58	66	68	28985	44
16	400	50	400	933	1.44	64	72	74	21700	70

U = Power supply · f = Frequency · n = Speed · P_{ed} = Power consumption · I = Current draw · LpA_{in} = Sound pressure level intake side · LwA_{in} = Sound power level intake side
 LwA_{out} = Sound power level outlet side · qv = Air flow · p_{fs} = Pressure increase

