

sickle-shaped blades (S series)

Fan housing with guide vanes

**ebm-papst Motor (Shanghai) Co., Ltd.**

No. 196, Yuntong Road, Pudong District,

Shanghai, China, 201299

W3G910-LV12-03/F01 ebmpapst Datasheet

sales@fansco.com

www.fansco.com

**Nominal data**

<b>Type</b>	<b>W3G910-LV12-03/F01</b>	
<b>Motor</b>	<b>M3G150-NA</b>	
Phase		3~
Nominal voltage	VAC	400
Nominal voltage range	VAC	380 .. 480
Frequency	Hz	50/60
Method of obtaining data		ml
Speed (rpm)	min <sup>-1</sup>	1070
Power consumption	W	3250
Current draw	A	5.0
Max. back pressure	Pa	300
Max. back pressure	in. wg	1.2
Min. ambient temperature	°C	-40
Max. ambient temperature	°C	60

ml = Max. load · me = Max. efficiency · fa = Free air · cs = Customer specification · ce = Customer equipment  
Subject to change

Occasional start-up at temperatures between -40 °C and -25 °C is permitted. For continuous operation at ambient temperatures below -25 °C (such as refrigeration applications), a fan design with special low-temperature bearings must be used.

**Data according to Commission Regulation (EU) 327/2011 (prEN 17166)**

		Actual	Req. 2015			
01 Overall efficiency $\eta_{es}$	%	59.3	36.8	09 Power consumption $P_{ed}$	kW	3.12
02 Measurement category		A		09 Air flow $q_v$	m <sup>3</sup> /h	24750
03 Efficiency category		Static		09 Pressure increase $p_{fs}$	Pa	256
04 Efficiency grade N		62.5	40	10 Speed (rpm) n	min <sup>-1</sup>	1070
05 Variable speed drive		Yes		11 Specific ratio*		1.00

Data obtained at optimum efficiency level.

\* Specific ratio =  $1 + p_{fs} / 100\,000\text{ Pa}$

LU-190226

The efficiency values displayed for achieving conformity with the Ecodesign Regulation EU 327/2011 has been reached with defined air duct components (e.g. inlet rings). The dimensions must be requested from ebm-papst. If other air conduction geometries are used on the installation side, the ebm-papst evaluation loses its validity/the conformity must be confirmed again.

The product does not fall within the scope of Regulation (EU) 2019/1781 due to the exception specified in Article 2 (2a) (motors completely integrated into a product).



## Technical description

<b>Weight</b>	54.6 kg
<b>Size</b>	910 mm
<b>Motor size</b>	150
<b>Rotor surface</b>	Painted black
<b>Electronics housing material</b>	Die-cast aluminum, painted gray
<b>Impeller material</b>	PP plastic
<b>Fan housing material</b>	Sheet steel, galvanized and coated with black plastic (RAL 9005)
<b>Material guide vanes</b>	PP plastic
<b>Guard grille material</b>	Steel, coated with black plastic (RAL 9005)
<b>Internal diffuser material including cover</b>	PP plastic
<b>Number of blades</b>	5
<b>Blade pitch</b>	0°
<b>Airflow direction</b>	V
<b>Direction of rotation</b>	Clockwise, viewed toward rotor
<b>Degree of protection</b>	IP55
<b>Insulation class</b>	"F"
<b>Moisture (F) / Environmental (H) protection class</b>	H2
<b>Ambient temperature note</b>	Occasional start-up at temperatures between -40°C and -25°C is permitted. For continuous operation at ambient temperatures below -25°C (such as refrigeration applications), use must be made of a fan design with special low-temperature bearings.
<b>Max. permitted ambient temp. for motor (transport/storage)</b>	+80 °C
<b>Min. permitted ambient temp. for motor (transport/storage)</b>	-40 °C
<b>Installation position</b>	Shaft horizontal or rotor on bottom; rotor on top on request
<b>Condensation drainage holes</b>	On rotor side
<b>Mode</b>	S1
<b>Motor bearing</b>	Ball bearing
<b>Technical features</b>	<ul style="list-style-type: none"> <li>- Operation and alarm display with LED</li> <li>- External 15-50 VDC input (parameterization)</li> <li>- Alarm relay</li> <li>- Integrated PI controller</li> <li>- Configurable inputs/outputs (I/O)</li> <li>- MODBUS V6.3</li> <li>- Motor current limitation</li> <li>- RS-485 MODBUS-RTU</li> <li>- Soft start</li> <li>- Voltage output 3.3-24 VDC, Pmax = 800 mW</li> <li>- Control interface with SELV potential safely disconnected from the mains</li> <li>- Thermal overload protection for electronics/motor</li> <li>- Line undervoltage / phase failure detection</li> </ul>
<b>EMC immunity to interference</b>	According to EN 61000-6-2 (industrial environment)
<b>EMC interference emission</b>	According to EN 61000-6-3 (household environment), except EN 61000-3-2 for professionally used equipment with a total rated power greater than 1 kW
<b>Touch current according to IEC 60990 (measuring circuit Fig. 4, TN system)</b>	<= 3.5 mA

# EC axial fan - AxiBlade

sickle-shaped blades (S series)

Fan housing with guide vanes

<b>Electrical hookup</b>	Terminal box
<b>Motor protection</b>	Reverse polarity and locked-rotor protection
<b>Protection class assignment</b>	I; If a protective earth is connected by the customer This component for installation may have several local protection classes. This information relates to this component's basic design. The final protection class is based on the component's intended installation and connection.
<b>Conformity with standards</b>	EN 61800-5-1; CE; UKCA
<b>Approval</b>	CSA C22.2 No. 77 + CAN/CSA-E60730-1; UL 1004-7 + 60730-1

# EC axial fan - AxiBlade

sickle-shaped blades (S series)

Fan housing with guide vanes

## Product drawing

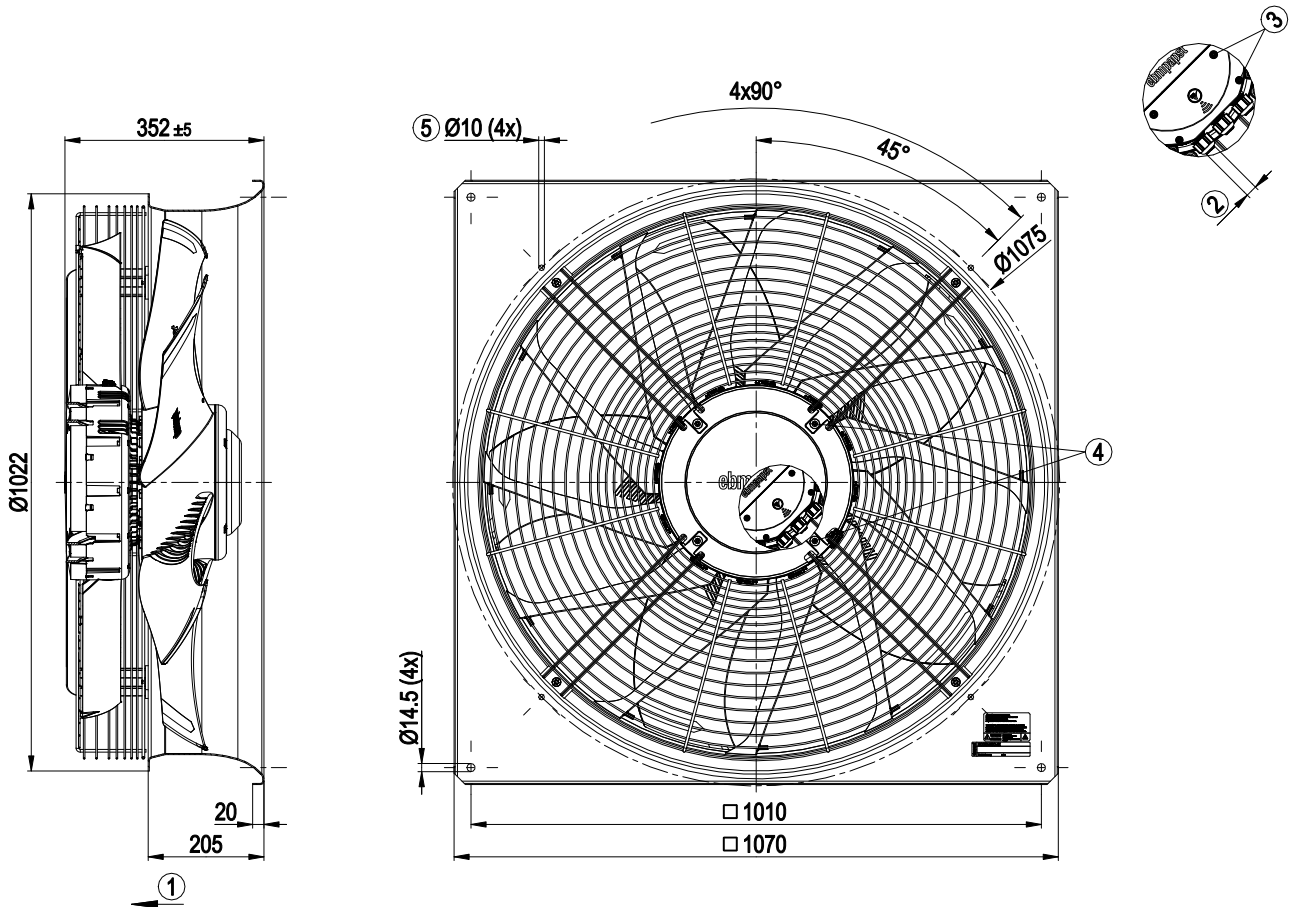

1	Airflow direction "V"
2	Cable diameter min. 4 mm, max. 10 mm, tightening torque $4 \pm 0.6$ Nm (The tightening torque is designed for PVC cables. If the cable materials are different, the tightening torque may have to be adjusted)
3	Tightening torque $1.5 \pm 0.2$ Nm
4	Tightening torque $3 \pm 0.3$ Nm
5	Attachment holes for FlowGrid (91000-2-2957 not included in scope of delivery)



# EC axial fan - AxiBlade

sickle-shaped blades (S series)

Fan housing with guide vanes

## Mounting dimensions

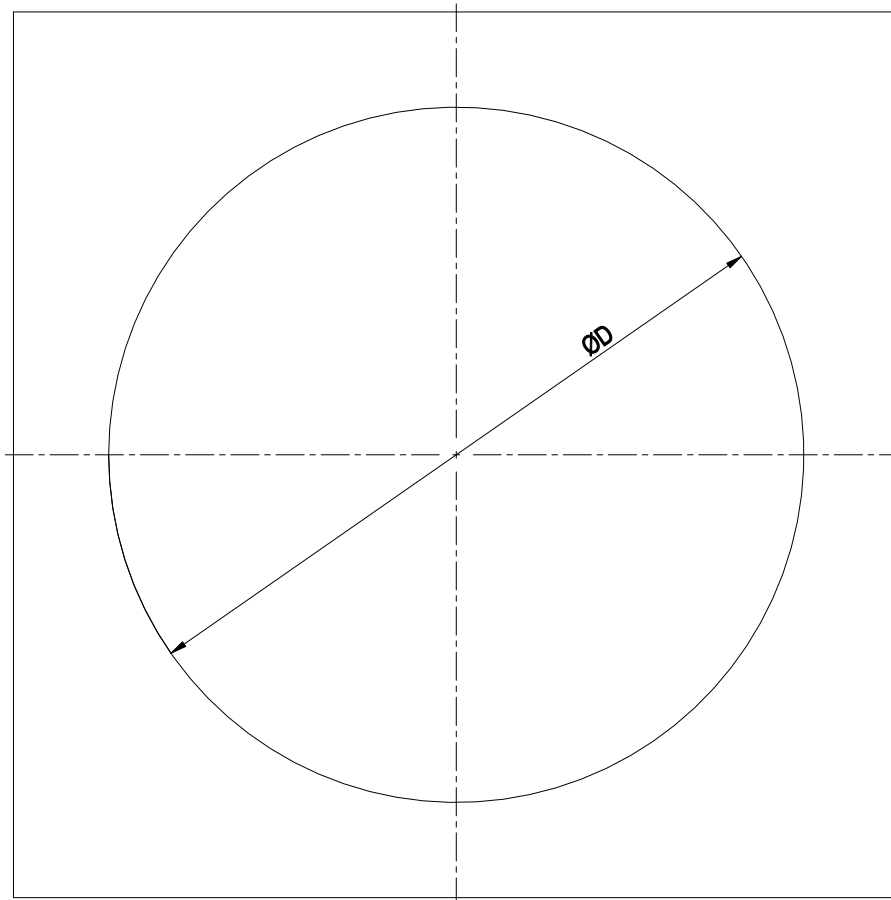

Diameter of the necessary recess for mounting the fan housing in the end device

BG630: D =  $\varnothing$ 785 mm

BG710: D =  $\varnothing$ 830 mm

BG800: D =  $\varnothing$ 950 mm

BG910: D =  $\varnothing$ 1050 mm

# EC axial fan - AxiBlade

sickle-shaped blades (S series)

Fan housing with guide vanes

## Connection diagram

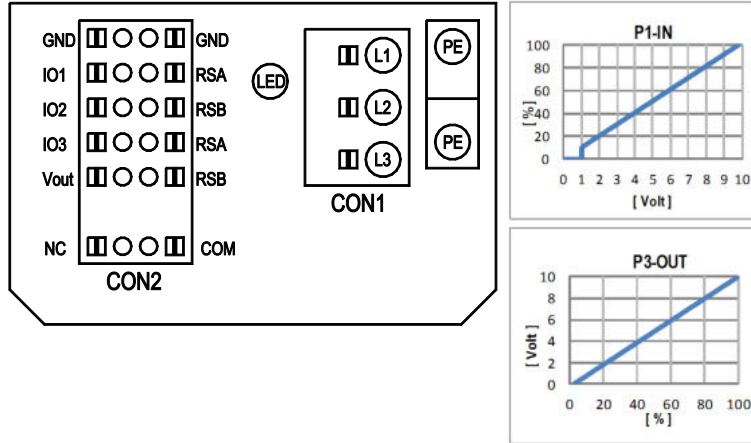

No.	Conn.	Designation	Function/assignment
	CON1	L1, L2, L3	Power supply, phase, see nameplate for voltage range
	PE	PE	Protective earth
	CON2	RSA	RS485 interface for MODBUS, RSA; SELV
	CON2	RSB	RS485 interface for MODBUS, RSB; SELV
	CON2	GND	Reference ground for control interface, SELV
	CON2	IO1	Function parameterizable (see "Optional interface functions" table) Factory setting: Digital input - high active, function: Disable input, SELV - inactive: Pin open or applied voltage < 1.5 VDC - active: applied voltage 3.5-50 VDC Reset function: Triggering of error reset on change of state from "enabled" to "disabled"
	CON2	IO2	Function parameterizable (see "Optional interface functions" table) Factory setting: Analog input 0-10 V / PWM, Ri=100 kΩ, function: Set value Characteristic curve parameterizable (see input characteristic curve P1-IN), SELV
	CON2	IO3	Function parameterizable (see "Optional interface functions" table) Factory setting: Analog output 0-10 V, max. 5 mA, function: Fan modulation level Characteristic curve parameterizable (see output characteristic curve P3-OUT), SELV
	CON2	Vout	Voltage output 3.3-24 VDC ±5%, Pmax=800 mW, voltage parameterizable Factory setting: 10 VDC short-circuit-proof, supply for external devices, SELV alternatively: 15-50 VDC input for parameterization via MODBUS without line voltage
	CON2	COM	Status relay, floating status contact, common connection, contact rating 250 VAC / 2 A (AC1) / min. 10 mA, reinforced insulation on supply side and on control interface side
	CON2	NC	Status relay, floating status contact, break for failure
		LED	green: status = good, ready for operation orange: status = warning red: status = failure
		P1-IN	Input characteristic curve
		P3-OUT	Output characteristic curve



## Terminal/plug assignment

CON2	configurable IO mode	electrical specification	configurable IO functions: normal / inverse	MODBUS Register for IO mode configuration	
				source: set value	switch: fan enable / disable
IO1	○ Din1 (active high), digital input	active: applied voltage 3.5-50VDC, SELV not active: pin open or applied voltage < 1.5VDC		○	D158 [0]
	○ Ain1 0-10V/PWM: analog input	RI = 100k, characteristic curve parameterizable, $f_{PWM} = 1k..10kHz$ , SELV		○	D158 [2]
	○ Tach out (open collector output)	Umax = 50VDC, Imax = 20mA, SELV		○	D158 [5]
	○ Diagnostics out (open collector output)	Umax = 50VDC, Imax = 20mA, SELV		○	D158 [6]
IO2	○ Din2 (active high), digital input	active: applied voltage 3.5-50VDC, SELV not active: pin open or applied voltage < 1.5VDC		○	D159 [0]
	○ Ain2 0-10V/PWM: analog input	RI = 100k, characteristic curve parameterizable, $f_{PWM} = 1k..10kHz$ , SELV		○	D159 [2]
	○ Ain2.4-20mA: analog input	RI = 125R, characteristic curve parameterizable, SELV		○	D159 [3]
	○ Din3 (active high), digital input	active: applied voltage 3.5-50VDC, SELV not active: pin open or applied voltage < 1.5VDC		○	D15A [0]
IO3	○ Din3 (active low), digital input	active: applied voltage < 1.5VDC, SELV not active: pin open or applied voltage 3.5-50VDC		○	D15A [1]
	○ PWMIn3: digital input, idle level high	PWM = 40Hz - 10kHz, characteristics parameterizable active: pin open or applied voltage 3.5-50VDC not active: applied voltage < 1.5VDC, SELV		○	D15A [7]
	○ PWMIn3: digital input, idle level low	40Hz - 10kHz, characteristics parameterizable active: applied voltage 3.5-50VDC not active: pin open or applied voltage < 1.5VDC, SELV		○	D15A [8]
	○ Aout3 0-10V: analog output	function parameterizable, max. 5mA max output frequency 300Hz, SELV		○	D15A [4]
RSA	○ Tacho out (pulses), analog output	0-10V/max. 5mA max output frequency 300Hz, SELV		○	D15A [5]
	○ Diagnostics out (pulses)	0-10V/max. 5mA max output frequency 300Hz, SELV		○	D15A [6]
	○ RSA485 bus connection,	MODBUS RTU, specification V6.3, SELV		○	
RSB					
Vout	voltage output	voltage parameterizable 3.3..24VDC +/- 5%, Pmax=800mW, short-circuit-proof, supply for external devices, SELV			D16E [..]
	alternatively: Input auxiliary power supply for parameterization via RS485/MODBUS RTU without line voltage	15..50VDC			

○ configurable option

For further information and additional functions see EC Control Software, Fan-Set-App, or MODBUS Parameter Specification V6.3



# EC axial fan - AxiBlade

sickle-shaped blades (S series)

Fan housing with guide vanes

## Curves: Air performance 50 Hz

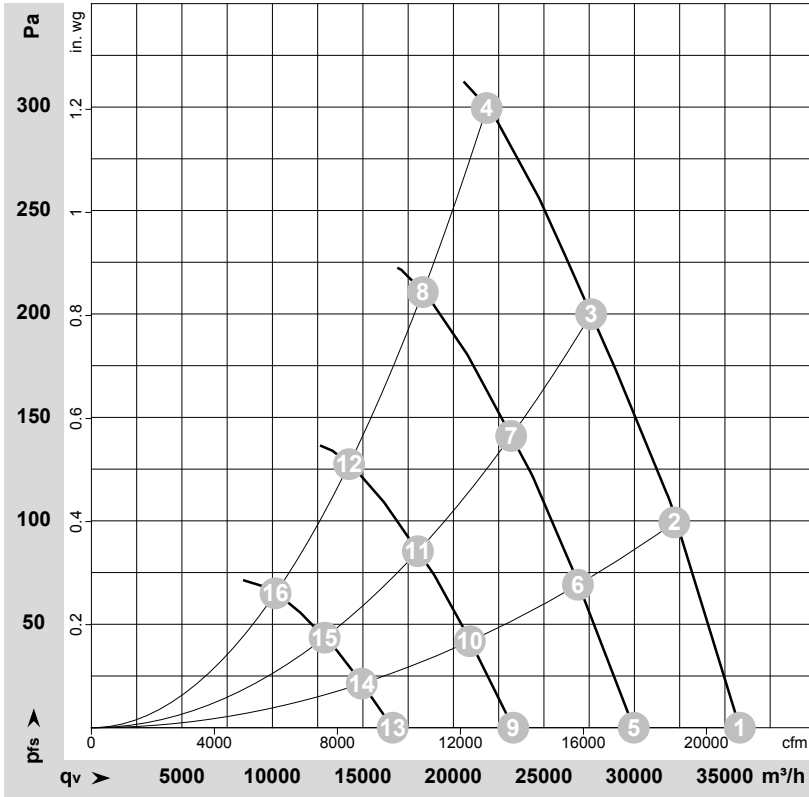

$\rho = 1.15 \text{ kg/m}^3 \pm 2 \%$

Measurement: LU-190226-1

Air performance measured according to ISO 5801 installation category A. For detailed information on the measurement setup, contact ebm-papst. Intake sound level: Sound power level according to ISO 13347 / sound pressure level measured at 1 m distance from fan axis. The values given are valid under the specified measuring conditions and may vary due to conditions of installation. For deviations from the standard configuration, the parameters have to be checked on the installed unit.

## Fan performance

	Wired	U	f	n	P <sub>ed</sub>	I	q <sub>v</sub>	P <sub>fs</sub>	q <sub>v</sub>	P <sub>fs</sub>
		V	Hz	min <sup>-1</sup>	W	A	m <sup>3</sup> /h	Pa	cfm	in. wg
1	3~	400	50	1070	2143	3.34	35825	0	21085	0.00
2	3~	400	50	1070	2624	4.05	32205	100	18955	0.40
3	3~	400	50	1070	2945	4.52	27610	200	16250	0.80
4	3~	400	50	1070	3250	5.00	21835	300	12855	1.20
5	3~	400	50	900	1254	1.95	29965	0	17635	0.00
6	3~	400	50	900	1511	2.33	26880	70	15820	0.28
7	3~	400	50	900	1745	2.68	23190	141	13650	0.57
8	3~	400	50	900	1925	2.95	18310	211	10775	0.85
9	3~	400	50	700	590	0.92	23305	0	13715	0.00
10	3~	400	50	700	711	1.10	20905	42	12305	0.17
11	3~	400	50	700	821	1.26	18035	85	10615	0.34
12	3~	400	50	700	906	1.39	14240	128	8380	0.51
13	3~	400	50	500	215	0.34	16645	0	9795	0.00
14	3~	400	50	500	259	0.40	14935	22	8790	0.09
15	3~	400	50	500	299	0.46	12885	44	7585	0.18
16	3~	400	50	500	330	0.51	10170	65	5985	0.26

Wired = Wiring · U = Voltage · f = Frequency · n = Speed (rpm) · P<sub>ed</sub> = Power consumption · I = Current draw · q<sub>v</sub> = Air flow · P<sub>fs</sub> = Pressure increase

