

sickled blades (S series)

with full square nozzle

ebm-papst Motor (Shanghai) Co., Ltd.No. 196, Yuntong Road, Pudong District,
Shanghai, China, 201299

W3G910-KU25-03/F02 ebmpapst Datasheet

sales@fansco.com

www.fansco.com

Nominal data

Type	W3G910-KU25-03/F02	
Motor	M3G150-IF	
Phase		3~
Nominal voltage	VAC	400
Nominal voltage range	VAC	380 .. 480
Frequency	Hz	50/60
Type of data definition		ml
Speed (rpm)	min ⁻¹	980
Power input	W	2550
Current draw	A	3.9
Max. back pressure	Pa	220
Min. ambient temperature	°C	-40
Max. ambient temperature	°C	60

ml = Max. load · me = Max. efficiency · fa = Running at free air · cs = Customer specs · cu = Customer unit
Subject to alterations

Occasional start-up between -40 °C and -25 °C is permissible. For continuous operation at ambient temperatures below -25 °C (such as refrigeration applications), a fan design with special low-temperature bearings must be used.

Data in accordance with ecodesign regulation EU 327/2011 (prEN 17166)

	Actual	Request 2015				
01 Overall efficiency η_{es}	%	53.2	36.1	09 Power input P_{ed}	kW	2.38
02 Measurement category		A		09 Air flow q_v	m ³ /h	23685
03 Efficiency category		Static		09 Pressure increase p_{fs}	Pa	182
04 Efficiency grade N		57.1	40	10 Speed (rpm) n	min ⁻¹	980
05 Variable speed drive		Yes		11 Specific ratio [*]		1.00

Data definition with optimum efficiency.

^{*} Specific ratio = $1 + p_{fs} / 100\,000\text{ Pa}$

LU-184391

The indicated efficiency values for obtaining conformity with the Ecodesign Directive EU 327/2011 were achieved with defined air conduction components (e.g. inlet nozzles).
The dimensions are to be requested from ebm-papst. If other air guide geometries are used on the installation side, the ebm-papst evaluation loses its validity/conformity must be confirmed again.
The product does not fall within the scope of Regulation (EU) 2019/1781 due to the exception specified in Article 2(2a) (motors completely integrated into a product).



Technical features

Mass	47 kg
Size	910 mm
Motor size	150
Surface of rotor	Coated in black
Material of electronics housing	Die-cast aluminium, painted grey
Material of impeller	PP plastic
Material of wall ring	Sheet steel, galvanised and coated in black plastic (RAL 9005)
Material of guard grille	Steel, coated in black plastic (RAL9005)
Number of blades	5
Blade angle	0°
Direction of air flow	V
Direction of rotation	Clockwise, seen on rotor
Type of protection	IP55
Insulation class	"F"
Humidity (F) / environmental protection class (H)	H2
Note ambient temperature	Occasional start-up between -40 °C and -25 °C is permissible. For continuous operation at ambient temperatures below -25 °C (e.g. refrigeration applications), a fan version with special low-temperature bearings must be used.
Max. permissible ambient motor temp. (transp./ storage)	+80 °C
Min. permissible ambient motor temp. (transp./storage)	-40 °C
Mounting position	Shaft horizontal or rotor on bottom; rotor on top on request
Condensation drainage holes	Rotor-side
Operation mode	S1
Motor bearing	Ball bearing
Technical features	<ul style="list-style-type: none"> - Operation and alarm display via LED - External 15-50 VDC input (parametrisation) - Alarm relay - Integrated PI controller - Configurable inputs/outputs (I/O) - MODBUS V6.3 - Motor current limit - RS485 MODBUS RTU - Soft start - Voltage output 3.3-24 VDC, Pmax = 800 mW - Control interface with SELV potential safely disconnected from the mains - Over-temperature protected electronics / motor - Line undervoltage / phase failure detection
EMC interference immunity	Acc. to EN 61000-6-2 (industrial environment)
EMC interference emission	Acc. to EN 61000-6-3 (household environment), except EN 61000-3-2 for professionally used devices with a total rated power greater than 1 kW
Touch current acc. IEC 60990 (measuring network Fig. 4, TN system)	<= 3.5 mA
Electrical connection	Terminal box
Motor protection	Reverse polarity and locked-rotor protection

EC axial fan - AxiBlade

sickled blades (S series)

with full square nozzle

Safety classification	I; If a protective earth is connected by the customer This component to be built-in can have several local protection class ratings. The specification refers to the basic design of this component. The final protection class is based on the intended installation and connection of the component.
Product conforming to standard	EN 61800-5-1; CE
Approval	UL 1004-7 + 60730-1; CSA C22.2 no. 77 + CAN/CSA-E60730-1
Remark	Perm. operating altitude up to max. 4000 m above sea level as per DIN 61800-5-1_2008_Sect. 4.3.6.4.1 Overvoltage category II. Up to 2000 m above sea level Overvoltage category III applies.

Preliminary



EC axial fan - AxiBlade

sickled blades (S series)

with full square nozzle

Product drawing

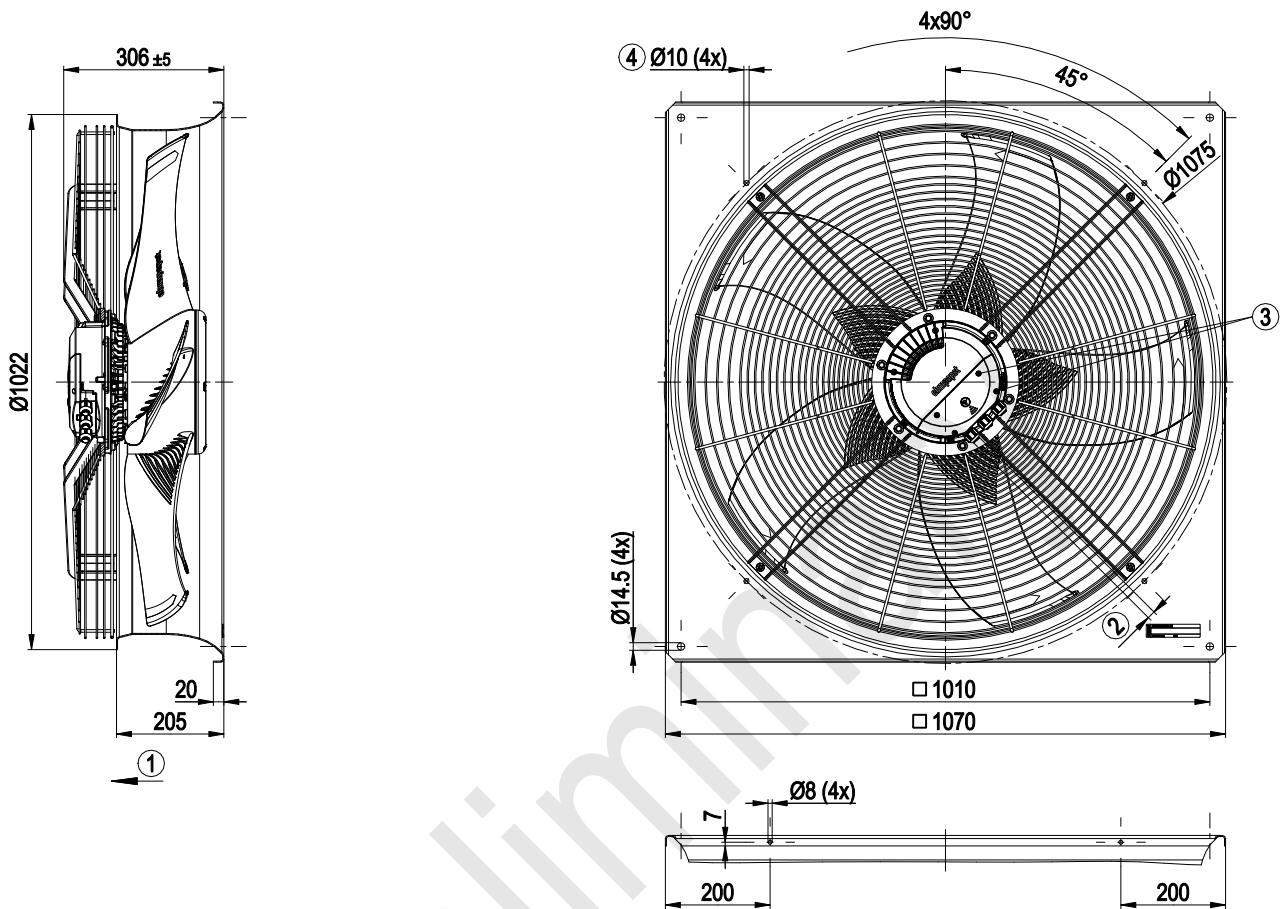

1	Direction of air flow "V"
2	Cable diameter min. 4 mm, max. 10 mm, tightening torque 4 ± 0.6 Nm (The tightening torque is designed for PVC cables. If the cable materials are different, the tightening torque may need to be adapted)
3	Tightening torque 1.5 ± 0.2 Nm
4	Attachment holes for FlowGrid (91000-2-2957 not included in scope of delivery)

EC axial fan - AxiBlade

sickled blades (S series)
with full square nozzle

Connection screen

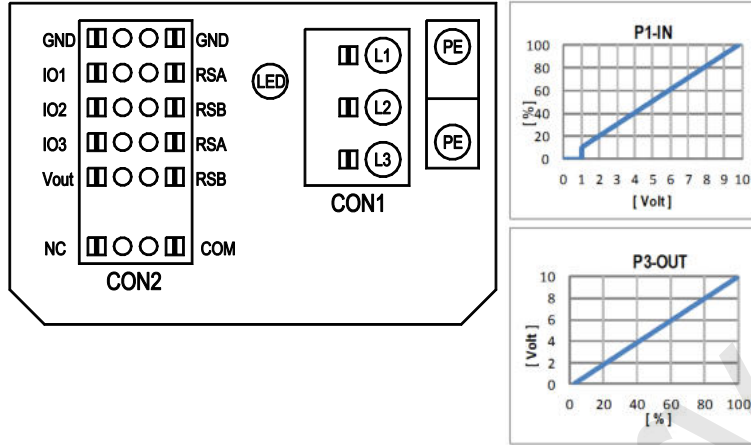

No.	Conn.	Designation	Function / assignment
	CON1	L1, L2, L3	Power supply, phase, see type plate for voltage range
	PE	PE	Protective earth
	CON2	RSA	RS-485 interface for MODBUS, RSA; SELV
	CON2	RSB	RS-485 interface for MODBUS, RSB; SELV
	CON2	GND	Signal ground for control interface, SELV
	CON2	IO1	Function parametrisable (see "Optional interface functions" table) Factory setting: Digital input - high active, function: Disable input, SELV - inactive: Pin open or applied voltage < 1.5 VDC - active: applied voltage 3.5-50 VDC Reset function: fault reset triggered by status change from enabled to disabled
	CON2	IO2	Function parametrisable (see "Optional interface functions" table) Factory setting: Analogue input 0-10 V / PWM, Ri=100 kΩ, function: Set value Curve parametrisable (see input curve P1-IN), SELV
	CON2	IO3	Function parametrisable (see "Optional interface functions" table) Factory setting: Analogue output 0-10 V, max. 5 mA, function: Fan modulation level Curve parametrizable (see output curve P3-OUT), SELV
	CON2	Vout	Voltage output 3.3-24 VDC +/-5%, Pmax=800 mW, voltage parametrisable Factory setting: 10 VDC short-circuit-proof, supply for external devices, SELV alternatively: 15-50 VDC input for parametrisation via MODBUS without mains power
	CON2	COM	Status relay, floating status contact, common connection, contact rating 250 VAC/max. 2 A (AC1) min. 10 mA, reinforced insulation with respect to mains and control interface
	CON2	NC	Status relay, floating status contact, break for failure
		LED	green = OK status, ready for operation orange = Warning status red = Error status
		P1-IN	Input curve
		P3-OUT	Output curve



Terminal/pin assignment

CON2	configurable IO mode	electrical specification	configurable IO functions: normal / inverse	MODBUS Register for IO mode configuration	
				MODBUS Register for IO mode configuration	MODBUS Register for IO mode configuration
IO1	○ Din1 (active high), digital input	active: applied voltage 3.5-50VDC, SELV not active: pin open or applied voltage < 1.5VDC		D158 [0]	
	○ Ain1 0-10V/PWM: analog input	RI = 100k, characteristic curve parameterizable, $f_{PWM} = 1k..10kHz$, SELV		D158 [2]	
	○ Tach out (open collector output)	Umax = 50VDC, Imax = 20mA, SELV		D158 [5]	
	○ Diagnostics out (open collector output)	Umax = 50VDC, Imax = 20mA, SELV		D158 [6]	
IO2	○ Din2 (active high), digital input	active: applied voltage 3.5-50VDC, SELV not active: pin open or applied voltage < 1.5VDC		D159 [0]	
	○ Ain2 0-10V/PWM: analog input	RI = 100k, characteristic curve parameterizable, $f_{PWM} = 1k..10kHz$, SELV		D159 [2]	
	○ Ain2.4-20mA: analog input	RI = 125R, characteristic curve parameterizable, SELV		D159 [3]	
	○ Din3 (active high), digital input	active: applied voltage 3.5-50VDC, SELV not active: pin open or applied voltage < 1.5VDC		D15A [0]	
IO3	○ Din3 (active low), digital input	active: applied voltage < 1.5VDC, SELV not active: pin open or applied voltage 3.5-50VDC		D15A [1]	
	○ PWMIn3: digital input, idle level high	PWM = 40Hz - 10kHz, characteristics parameterizable		D15A [7]	
	○ PWMIn3: digital input, idle level low	active: pin open or applied voltage 3.5-50VDC not active: applied voltage < 1.5VDC, SELV		D15A [8]	
	○ Aout3 0-10V: analog output	active: applied voltage 3.5-50VDC not active: pin open or applied voltage < 1.5VDC, SELV		D15A [4]	
	○ Tacho out (pulses), analog output	function parameterizable, max. 5mA max output frequency 300Hz SELV		D15A [5]	
	○ Diagnostics out (pulses)	0-10V/max. 5mA max output frequency 300Hz SELV 0-10V/max. 5mA max output frequency 300Hz, SELV		D15A [6]	
RSA	RS485 bus connection,	MODBUS RTU, specification V6.3, SELV			
RSB	voltage output	voltage parameterizable 3.3..24VDC +/- 5%, Pmax=600mW, short-circuit-proof, supply for external devices, SELV		D16E [..]	
Vout	alternatively: Input auxiliary power supply for parameterization via RS485/MODBUS RTU without line voltage	15..50VDC			

○ configurable option

For further information and additional functions see EC Control Software, Fan-Set-App, or MODBUS Parameter Specification V6.3



EC axial fan - AxiBlade

sickled blades (S series)

with full square nozzle

Charts: Air flow 50 Hz

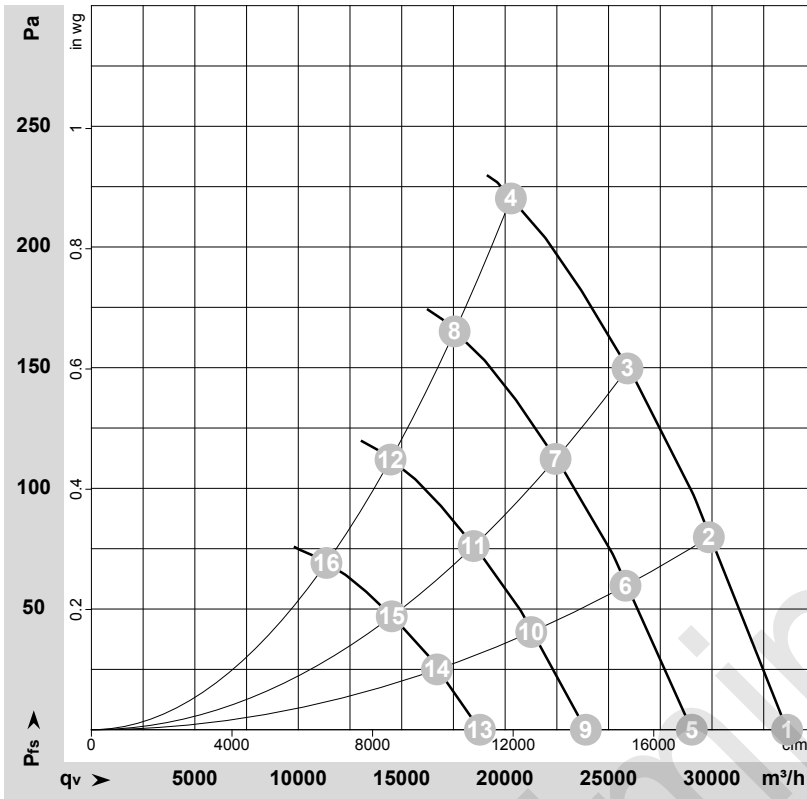

$\rho = 1.15 \text{ kg/m}^3 \pm 2 \%$

Measurement: LU-184391-1

Air performance measured as per ISO 5801 Installation category A. For detailed information on the measuring set-up, please contact ebmpapst. Suction-side noise levels: LwA measured as per ISO 13347 / LpA measured with 1m distance to fan axis. The values given are valid under the measuring conditions mentioned above and may vary according to the actual installation situation. With any deviation from the standard set-up, the specific values have to be checked and reviewed with the unit installed.

Fan performance

	U	f	n	P _{ed}	I	LpA _{in}	LwA _{in}	LwA _{out}	q _v	P _{fs}	q _v	P _{fs}
	V	Hz	min ⁻¹	W	A	dB(A)	dB(A)	dB(A)	m ³ /h	Pa	cfm	in. wg
1	400	50	980	1563	2.50	72	79	80	33630	0	19795	0.00
2	400	50	980	1938	3.04	69	76	77	29845	80	17565	0.32
3	400	50	980	2245	3.49	70	77	77	25915	150	15255	0.60
4	400	50	980	2550	3.90	75	82	82	20280	220	11935	0.88
5	400	50	850	1004	1.60	68	75	76	29025	0	17080	0.00
6	400	50	850	1255	1.97	66	73	74	25820	61	15195	0.24
7	400	50	850	1457	2.27	67	73	74	22440	112	13205	0.45
8	400	50	850	1663	2.57	72	78	79	17560	165	10335	0.66
9	400	50	700	561	0.90	63	70	71	23900	0	14070	0.00
10	400	50	700	701	1.10	61	68	69	21260	41	12515	0.16
11	400	50	700	814	1.27	62	68	69	18480	76	10875	0.31
12	400	50	700	929	1.44	67	74	74	14460	112	8510	0.45
13	400	50	550	272	0.43	57	64	65	18780	0	11055	0.00
14	400	50	550	340	0.53	55	62	63	16705	26	9835	0.10
15	400	50	550	395	0.61	56	62	63	14520	47	8545	0.19
16	400	50	550	451	0.70	61	67	68	11360	69	6685	0.28

U = Supply voltage · f = Frequency · n = Speed (rpm) · P_{ed} = Power input · I = Current draw · LpA_{in} = Sound pressure level inlet side · LwA_{in} = Sound power level inlet side · LwA_{out} = Sound power level outlet side
 q_v = Air flow · P_{fs} = Pressure increase

