

EC axial fan - HyBlade

sickle-shaped blades (S series)

with square full nozzle

ebm-papst Ventilator (Shanghai) Co.,Ltd.

No.418, Hua Jing Road, Wai Gao Qiao Free Trade Zone, Pudong

83

W3G910-GV02-01/F02 ebmpapst Datasheet

sales@fansco.com

www.fansco.com

Nominal data

| | | |
|--------------------------|--------------------|------------|
| Type | W3G910-GV02-01/F02 | |
| Motor | M3G150-NA | |
| Phase | | 3~ |
| Nominal voltage | VAC | 400 |
| Nominal voltage range | VAC | 380 .. 480 |
| Frequency | Hz | 50/60 |
| Method of obtaining data | | ml |
| Speed (rpm) | min ⁻¹ | 1000 |
| Power consumption | W | 2880 |
| Current draw | A | 4.4 |
| Max. back pressure | Pa | 190 |
| Max. back pressure | inH ₂ O | 0.76 |
| Min. ambient temperature | °C | -25 |
| Max. ambient temperature | °C | 65 |

ml = Max. load · me = Max. efficiency · fa = Free air · cs = Customer specification · ce = Customer equipment
Subject to change

Data according to ErP Directive

| | | Actual | Req. 2015 | | | |
|-----------------------------------|---|--------|-----------|-------------------------------|-------------------|-------|
| 01 Overall efficiency η_{es} | % | 44.5 | 36.6 | 09 Power consumption P_{ed} | kW | 2.93 |
| 02 Measurement category | | A | | 09 Air flow q_v | m ³ /h | 22085 |
| 03 Efficiency category | | Static | | 09 Pressure increase p_{fs} | Pa | 202 |
| 04 Efficiency grade N | | 47.9 | 40 | 10 Speed (rpm) n | min ⁻¹ | 1005 |
| 05 Variable speed drive | | Yes | | 11 Specific ratio* | | 1.00 |

Data obtained at optimum efficiency level.

The ErP data is determined using a motor-impeller combination in a standardized measurement setup.

* Specific ratio = $1 + p_s / 100\,000\text{ Pa}$

LU-119173



EC axial fan - HyBlade

sickle-shaped blades (S series)

with square full nozzle

Technical description

| | |
|---|---|
| Weight | 57 kg |
| Fan size | 910 mm |
| Rotor surface | Painted black |
| Electronics housing material | Die-cast aluminum, painted black |
| Blade material | Sheet aluminum insert, sprayed with PP plastic |
| Fan housing material | Sheet steel, pre-galvanized and coated with black plastic (RAL 9005) |
| Guard grille material | Steel, coated with black plastic (RAL 9005) |
| Number of blades | 5 |
| Blade pitch | 0° |
| Airflow direction | "V" |
| Direction of rotation | Clockwise, viewed toward rotor |
| Degree of protection | IP55 |
| Insulation class | "F" |
| Moisture (F) / Environmental (H) protection class | F4-1 |
| Max. permitted ambient temp. for motor (transport/storage) | + 80 °C |
| Min. permitted ambient temp. for motor (transport/storage) | - 40 °C |
| Installation position | Shaft horizontal or rotor on bottom; rotor on top on request |
| Condensation drainage holes | On rotor side |
| Mode | S1 |
| Motor bearing | Ball bearing |
| Technical features | <ul style="list-style-type: none"> - Output 10 VDC, max. 10 mA - Output 20 VDC, max. 50 mA - Output for slave 0-10 V - Operation and alarm display - Input for sensor 0-10 V or 4-20 mA - External 24 V input (parameter setting) - External release input - Alarm relay - Integrated PID controller - Motor current limitation - PFC, passive - RS-485 MODBUS-RTU - Soft start - Control input 0-10 VDC / PWM - Control interface with SELV potential safely disconnected from supply - Thermal overload protection for electronics/motor - Line undervoltage / phase failure detection |
| EMC immunity to interference | According to EN 61000-6-2 (industrial environment) |
| EMC interference emission | According to EN 61000-6-3 (household environment) |
| Touch current according to IEC 60990 (measuring circuit Fig. 4, TN system) | <= 3.5 mA |
| Electrical hookup | Via terminal box |
| Motor protection | Reverse polarity and locked-rotor protection |
| Protection class | I (with customer connection of protective earth) |
| Conformity with standards | EN 61800-5-1; CE |



EC axial fan - HyBlade

sickle-shaped blades (S series)

with square full nozzle

Approval

EAC; UL 1004-7 + 60730; C22.2 No.77 + CAN/CSA-E60730-1



EC axial fan - HyBlade

sickle-shaped blades (S series)

with square full nozzle

Product drawing

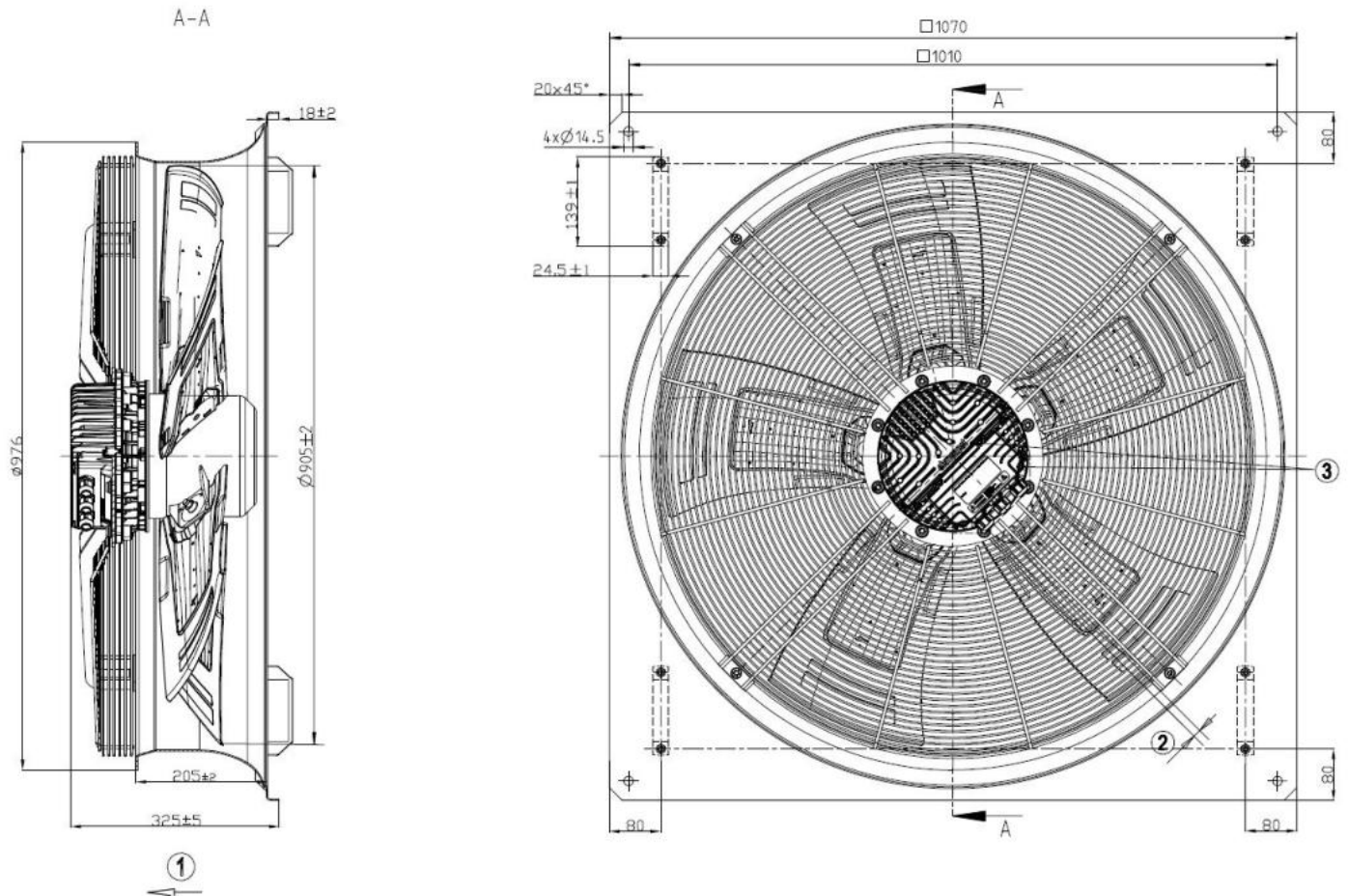

| | |
|---|--|
| 1 | Direction of air flow "V" |
| 2 | Cable diameter min. 4 mm, max. 10 mm, tightening torque 4 ± 0.6 Nm |
| 3 | Tightening torque 3.5 ± 0.5 Nm |



EC axial fan - HyBlade

sickle-shaped blades (S series)

with square full nozzle

Connection diagram

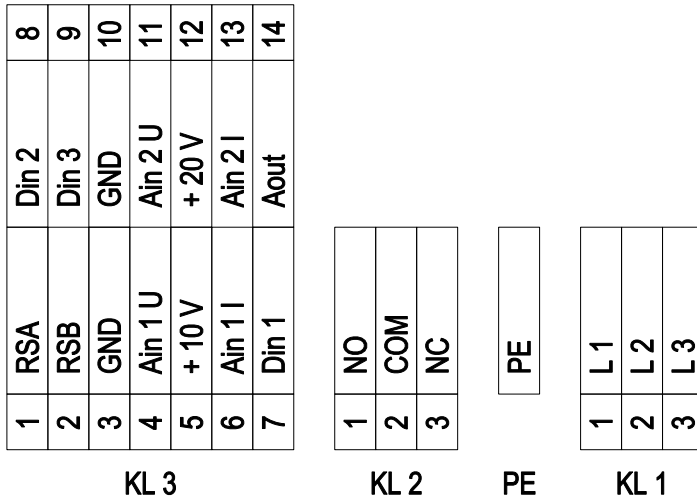

| No. | Conn. | Designation | Function/assignment |
|------|--------|-------------|--|
| KL 1 | 1 | L1 | Supply connection, power supply 3-phase 380-480 VAC, 50/60 Hz |
| KL 1 | 2 | L2 | Supply connection, power supply 3-phase 380-480 VAC, 50/60 Hz |
| KL 1 | 3 | L3 | Supply connection, power supply 3-phase 380-480 VAC, 50/60 Hz |
| PE | | PE | Ground connection, PE connection |
| KL 2 | 1 | NO | Status relay, floating status contact; make for failure |
| KL2 | 2 | COM | Status relay, floating status contact; changeover contact; common connection; contact rating 250 VAC / max. 2 A (AC1) / min. 10 mA |
| KL2 | 3 | NC | Status relay, floating status contact; break for failure |
| KL 3 | 1 | RSA | Bus connection RS485, RSA, MODBUS-RTU; SELV |
| KL 3 | 2 | RSB | Bus connection RS485, RSB, MODBUS-RTU; SELV |
| KL 3 | 3 / 10 | GND | Reference ground for control interface; SELV |
| KL 3 | 4 | Ain1 U | Analog input 1, set value: 0-10 V, Ri = 100 kΩ, adjustable curve, only usable as alternative to input Ain1 I; SELV |
| KL 3 | 5 | + 10 V | Fixed voltage output 10 VDC, +10 V ±3%, max. 10 mA, short-circuit-proof power supply for external devices (e.g. pot); SELV |
| KL 3 | 6 | Ain1 I | Analog input 1, set value: 4-20 mA, Ri = 100 Ω, adjustable curve, only usable as alternative to input Ain1U; SELV |
| KL 3 | 7 | Din1 | Digital input 1: enable electronics, enable: pin open or applied voltage 5-50 VDC disable: bridge to GND or applied voltage < 1 VDC reset function: triggers software reset after a level change to < 1 VDC; SELV |
| KL 3 | 8 | Din2 | Digital input 2: Switching parameter sets 1/2, according to EEPROM setting, the valid or used parameter set can be selected via bus or via digital input DIN2. Parameter set 1: pin open or applied voltage 5-50 VDC Parameter set 2: bridge to GND or applied voltage < 1 VDC; SELV |
| KL 3 | 9 | Din3 | Digital input 3: according to EEPROM setting, the integrated controller's direction of action can be selected as normal/inverse via bus or digital input normal: pin open or applied voltage 5-50 VDC inverse: bridge to GND or applied voltage < 1 VDC; SELV |
| KL 3 | 11 | Ain2 U | Analog input 2, measured value: 0-10 V, Ri = 100 kΩ, adjustable curve, only usable as alternative to input Ain2I; SELV |
| KL 3 | 12 | + 20 V | Fixed voltage output 20 VDC, +20 V ±5/-10%, max. 50 mA, short-circuit-proof power supply for external devices (e.g. sensors); SELV |



EC axial fan - HyBlade

sickle-shaped blades (S series)

with square full nozzle

| No. | Conn. | Designation | Function/assignment |
|------|-------|-------------|--|
| KL 3 | 13 | Ain2 I | Analog input 2, measured value: 4-20 mA, Ri = 100 Ω, adjustable curve, only usable as alternative to input Ain2U; SELV |
| KL 3 | 14 | Aout | Analog output 0-10 VDC, max. 5 mA, output of current motor modulation level / motor speed adjustable curve; SELV |



EC axial fan - HyBlade

sickle-shaped blades (S series)

with square full nozzle

Curves: Air performance 50 Hz

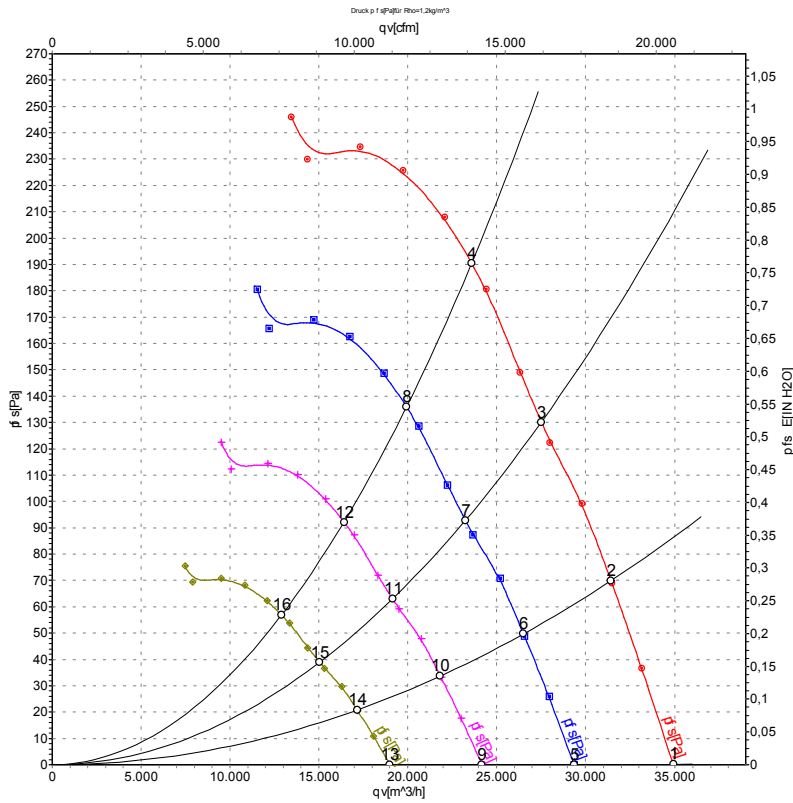

Measurement: LU-119173-1

Air performance measured according to ISO 5801 installation category A. For detailed information on the measurement setup, contact ebmpapst. Intake sound level: Sound power level according to ISO 13347 / sound pressure level measured at 1 m distance from fan axis. The values given are valid under the specified measuring conditions and may vary due to conditions of installation. For deviations from the standard configuration, the parameters have to be checked on the installed unit.

Measured values

| | U | f | n | P _{ed} | I | LpA _{in} | LwA _{in} | LwA _{out} | qv | P _{fs} | qv | P _{fs} |
|----|-----|----|-------------------|-----------------|------|-------------------|-------------------|--------------------|-------------------|-----------------|-------|-----------------|
| | V | Hz | min ⁻¹ | W | A | dB(A) | dB(A) | dB(A) | m ³ /h | Pa | CFM | inH2O |
| 1 | 400 | 50 | 1000 | 1922 | 2.91 | 72 | 79 | 80 | 34930 | 0 | 20560 | 0.00 |
| 2 | 400 | 50 | 1000 | 2286 | 3.49 | 71 | 78 | 78 | 31420 | 70 | 18495 | 0.28 |
| 3 | 400 | 50 | 1000 | 2581 | 3.94 | 71 | 78 | 78 | 27520 | 130 | 16200 | 0.52 |
| 4 | 400 | 50 | 1000 | 2880 | 4.40 | 74 | 82 | 81 | 23590 | 190 | 13885 | 0.76 |
| 5 | 400 | 50 | 850 | 1139 | 1.73 | 65 | 72 | 72 | 29340 | 0 | 17270 | 0.00 |
| 6 | 400 | 50 | 850 | 1371 | 2.09 | 67 | 74 | 74 | 26500 | 50 | 15595 | 0.20 |
| 7 | 400 | 50 | 850 | 1555 | 2.37 | 67 | 75 | 74 | 23240 | 93 | 13680 | 0.37 |
| 8 | 400 | 50 | 850 | 1722 | 2.66 | 71 | 78 | 77 | 19920 | 136 | 11725 | 0.55 |
| 9 | 400 | 50 | 700 | 636 | 0.96 | 61 | 68 | 68 | 24160 | 0 | 14220 | 0.00 |
| 10 | 400 | 50 | 700 | 766 | 1.17 | 63 | 70 | 70 | 21820 | 34 | 12845 | 0.14 |
| 11 | 400 | 50 | 700 | 869 | 1.33 | 63 | 70 | 70 | 19140 | 63 | 11265 | 0.25 |
| 12 | 400 | 50 | 700 | 962 | 1.48 | 67 | 74 | 73 | 16410 | 92 | 9660 | 0.37 |
| 13 | 400 | 50 | 550 | 309 | 0.47 | 56 | 63 | 63 | 18980 | 0 | 11170 | 0.00 |
| 14 | 400 | 50 | 550 | 371 | 0.57 | 57 | 65 | 65 | 17150 | 21 | 10095 | 0.08 |
| 15 | 400 | 50 | 550 | 421 | 0.64 | 58 | 65 | 65 | 15040 | 39 | 8850 | 0.16 |
| 16 | 400 | 50 | 550 | 467 | 0.72 | 61 | 68 | 68 | 12890 | 57 | 7585 | 0.23 |

U = Power supply · f = Frequency · n = Speed (rpm) · P_{ed} = Power consumption · I = Current draw · LpA_{in} = Sound pressure level intake side · LwA_{in} = Sound power level intake side
LwA_{out} = Sound power level outlet side · qv = Air flow · P_{fs} = Pressure increase

