

W3G910-GS39-75 ebmpapst Datasheet FansCo

sales@fansco.com

www.fansco.com

Nominal data

Type	W3G910-GS39-75	
Motor	M3G150-FF	
Phase		3~
Nominal voltage	VAC	400
Nominal voltage range	VAC	380 .. 480
Frequency	Hz	50/60
Method of obtaining data		ml
Speed (rpm)	min ⁻¹	800
Power consumption	W	1550
Current draw	A	2.5
Max. back pressure	Pa	130
Max. back pressure	in. wg	0.52
Min. ambient temperature	°C	-40
Max. ambient temperature	°C	60

ml = Max. load · me = Max. efficiency · fa = Free air · cs = Customer specification · ce = Customer equipment
Subject to change

Data according to Commission Regulation (EU) 327/2011

		Actual	Req. 2015
01 Overall efficiency η_{es}	%	48.1	34.6
02 Measurement category		A	
03 Efficiency category		Static	
04 Efficiency grade N		53.5	40
05 Variable speed drive		Yes	

Data obtained at optimum efficiency level.

The ErP data is determined using a motor-impeller combination in a standardized measurement setup.

09 Power consumption P_{ed}	kW	1.42
09 Air flow q_v	m ³ /h	21335
09 Pressure increase p_{fs}	Pa	108
10 Speed (rpm) n	min ⁻¹	800
11 Specific ratio*		1.00

* Specific ratio = $1 + p_{fs} / 100\,000\text{ Pa}$

LU-155034



W3G910-GS39-75

Heatcraft AU/NZ

EC axial fan - HyBlade

sickle-shaped blades (S series)

with square full nozzle

Technical description

Weight	42 kg
Size	910 mm
Motor size	150
Rotor surface	Painted black
Electronics housing material	Die-cast aluminum, painted black
Blade material	Sheet aluminum insert, sprayed with PP plastic
Support ring material	Steel, coated with black plastic (RAL 9005)
Fan housing material	Sheet steel, galvanized and coated with black plastic (RAL 9005)
Number of blades	5
Blade pitch	0°
Airflow direction	V
Direction of rotation	Clockwise, viewed toward rotor
Degree of protection	IP55
Insulation class	"F"
Moisture (F) / Environmental (H) protection class	H2
Ambient temperature note	Occasional start-up at temperatures between -40°C and -25°C is permitted. For continuous operation at ambient temperatures below -25°C (such as refrigeration applications), use must be made of a fan design with special low-temperature bearings.
Max. permitted ambient temp. for motor (transport/storage)	+80 °C
Min. permitted ambient temp. for motor (transport/storage)	-40 °C
Installation position	Shaft horizontal or rotor on bottom
Condensation drainage holes	On rotor side
Mode	S1
Motor bearing	Ball bearing
Technical features	<ul style="list-style-type: none">- Output 10 VDC, max. 10 mA- Operation and alarm display- External 24 V input (parameter setting)- External release input- Alarm relay- Integrated PID controller- Motor current limitation- PFC, passive- RS-485 MODBUS-RTU- Soft start- Control input 0-10 VDC / PWM- Control interface with SELV potential safely disconnected from the mains- Thermal overload protection for electronics/motor- Line undervoltage / phase failure detection
EMC immunity to interference	According to EN 61000-6-2 (industrial environment)
EMC interference emission	According to EN 61000-6-4 (industrial environment)
Touch current according to IEC 60990 (measuring circuit Fig. 4, TN system)	<= 3.5 mA
Electrical hookup	Terminal box
Motor protection	Reverse polarity and locked-rotor protection
Protection class	I (with customer connection of protective earth)



W3G910-GS39-75
Heatcraft AU/NZ

EC axial fan - HyBlade

sickle-shaped blades (S series)
with square full nozzle

Conformity with standards	EN 61800-5-1; CE
Approval	EAC



W3G910-GS39-75

Heatcraft AU/NZ

EC axial fan - HyBlade

sickle-shaped blades (S series)

with square full nozzle

Product drawing

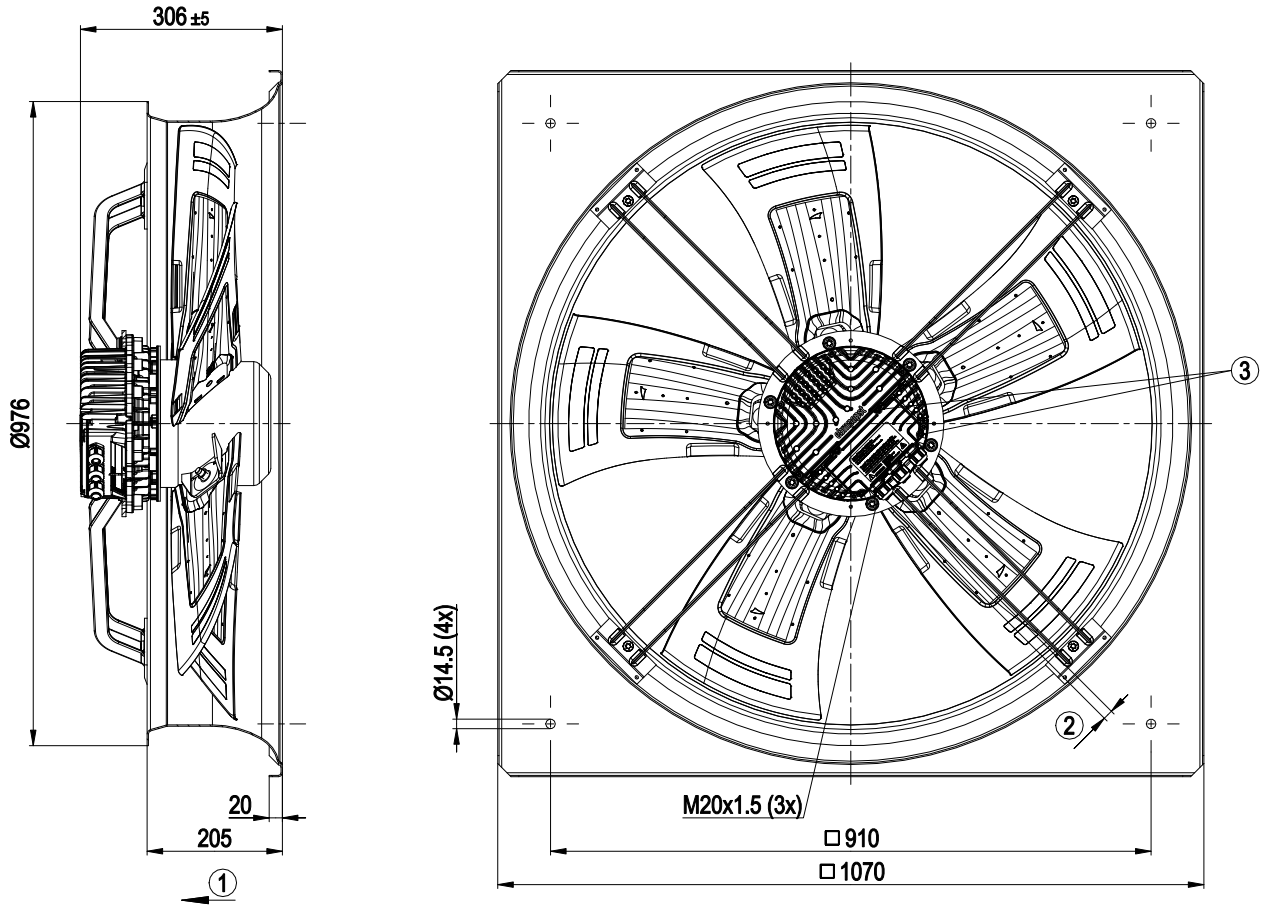

- | | |
|---|--|
| 1 | Direction of air flow "V" |
| 2 | Cable diameter min. 4 mm, max. 10 mm, tightening torque 4 ± 0.6 Nm |
| 3 | Tightening torque 3.5 ± 0.5 Nm |



EC axial fan - HyBlade

sickle-shaped blades (S series)
with square full nozzle

Connection diagram

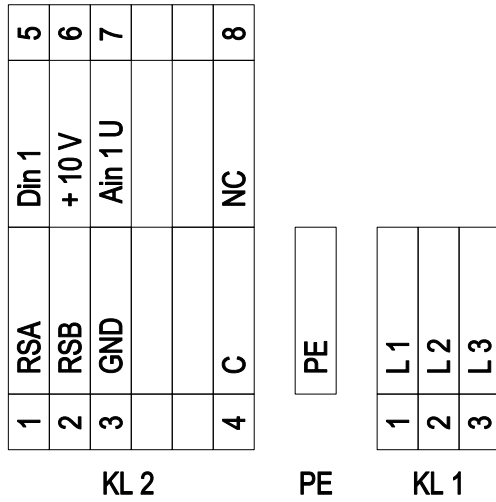

No.	Conn.	Designation	Function/assignment
KL 1	1	L1	Supply connection, power supply 3-phase 380-480 VAC, 50/60 Hz
KL 1	2	L2	Supply connection, power supply 3-phase 380-480 VAC, 50/60 Hz
KL 1	3	L3	Supply connection, power supply 3-phase 380-480 VAC, 50/60 Hz
PE		PE	Ground connection, PE connection
KL 2	1	RSA	Bus connection RS485, RSA, MODBUS-RTU; SELV
KL 2	2	RSB	Bus connection RS485, RSB, MODBUS-RTU; SELV
KL 2	3	GND	Reference ground for control interface; SELV
KL2	4	C	Status relay, floating status contact, break for failure; contact rating 250 VAC / max. 2 A (AC1) / min. 10 mA
KL 2	5	Din1	Digital input 1 enable electronics, enable: pin open or applied voltage 5-50 VDC disable: bridge to GND or applied voltage < 1 VDC reset function: triggers software reset after a level change to < 1 V; SELV
KL 2	6	+ 10 V	Fixed voltage output 10 VDC, +10 V ±3%, max. 10 mA, short-circuit-proof, power supply for external devices (e.g. pot); SELV Or: +24 VDC input for parameter setting via MODBUS without line voltage
KL 2	7	Ain1 U	Analog input 1 (set value) 0-10 V, Ri = 100 kΩ, adjustable curve; SELV
KL2	8	NC	Status relay, floating status contact, break for failure



EC axial fan - HyBlade

sickle-shaped blades (S series)
with square full nozzle

Curves: Air performance 50 Hz

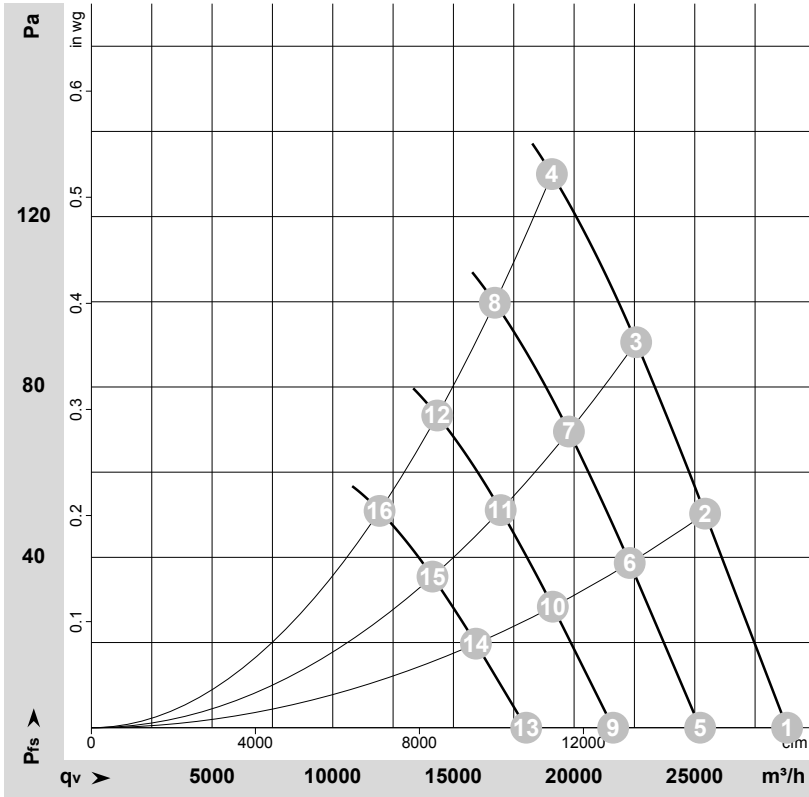

$\rho = 1.15 \text{ kg/m}^3 \pm 2 \%$

Measurement: LU-155034-1

Air performance measured according to ISO 5801 installation category A. For detailed information on the measurement setup, contact ebmpapst. Intake sound level: Sound power level according to ISO 13347 / sound pressure level measured at 1 m distance from fan axis. The values given are valid under the specified measuring conditions and may vary due to conditions of installation. For deviations from the standard configuration, the parameters have to be checked on the installed unit.

Measured values

	U	f	n	P _{ed}	I	LpA _{in}	LwA _{in}	LwA _{out}	q _v	P _{fs}	q _v	P _{fs}
	V	Hz	min ⁻¹	W	A	dB(A)	dB(A)	dB(A)	m ³ /h	Pa	cfm	in. wg
1	400	50	800	891	1.52	67	74	75	28825	0	16965	0.00
2	400	50	800	1158	1.90	65	73	73	25430	50	14965	0.20
3	400	50	800	1350	2.18	65	72	73	22575	90	13285	0.36
4	400	50	800	1550	2.50	67	74	75	19080	130	11230	0.52
5	400	50	700	597	1.02	63	71	71	25220	0	14845	0.00
6	400	50	700	781	1.28	62	69	70	22305	39	13130	0.16
7	400	50	700	909	1.47	61	69	69	19785	70	11645	0.28
8	400	50	700	1040	1.66	64	71	71	16715	100	9840	0.40
9	400	50	600	376	0.64	59	67	68	21620	0	12725	0.00
10	400	50	600	492	0.81	58	65	66	19120	28	11255	0.11
11	400	50	600	573	0.92	57	65	66	16960	51	9980	0.20
12	400	50	600	655	1.04	60	67	68	14330	73	8435	0.29
13	400	50	500	218	0.37	55	63	63	18015	0	10605	0.00
14	400	50	500	285	0.47	53	61	62	15930	20	9375	0.08
15	400	50	500	331	0.53	53	60	61	14130	35	8320	0.14
16	400	50	500	379	0.60	55	63	63	11940	51	7030	0.20

U = Voltage · f = Frequency · n = Speed (rpm) · P_{ed} = Power consumption · I = Current draw · LpA_{in} = Sound pressure level intake side · LwA_{in} = Sound power level intake side
LwA_{out} = Sound power level outlet side · q_v = Air flow · P_{fs} = Pressure increase

