

W3G800-GU21-03 ebmpapst Datasheet

sales@fansco.com

www.fansco.com

## Nominal data

Type	W3G800-GU21-03	
Motor	M3G150-IF	
Phase		3~
Nominal voltage	VAC	400
Nominal voltage range	VAC	380 .. 480
Frequency	Hz	50/60
Method of obtaining data		ml
Status		prelim.
Speed (rpm)	min <sup>-1</sup>	1100
Power consumption	W	3025
Current draw	A	4.6
Max. back pressure	Pa	260
Max. back pressure	in. wg	1.04
Min. ambient temperature	°C	-40
Max. ambient temperature	°C	60

ml = Max. load · me = Max. efficiency · fa = Free air · cs = Customer specification · ce = Customer equipment  
Subject to change

## Data according to Commission Regulation (EU) 327/2011

		Actual	Req. 2015		
01 Overall efficiency $\eta_{es}$	%	42.8	36.5	09 Power consumption $P_{ed}$	kW 2.79
02 Measurement category		A		09 Air flow $q_v$	m <sup>3</sup> /h 18955
03 Efficiency category		Static		09 Pressure increase $p_{fs}$	Pa 227
04 Efficiency grade N		46.3	40	10 Speed (rpm) n	min <sup>-1</sup> 1105
05 Variable speed drive		Yes		11 Specific ratio*	1.00

Data obtained at optimum efficiency level.  
The ErP data is determined using a motor-impeller combination in a standardized measurement setup.

\* Specific ratio =  $1 + p_g / 100\,000\text{ Pa}$ 

LU-202121



# EC axial fan - HyBlade

sickle-shaped blades (S series)

Fan housing with guard grille

## Technical description

Size	800 mm
Motor size	150
Rotor surface	Painted black
Electronics housing material	Die-cast aluminum, painted gray
Blade material	Sheet aluminum insert, sprayed with PP plastic
Fan housing material	Sheet steel, galvanized and coated with black plastic (RAL 9005)
Guard grille material	Steel, coated with black plastic (RAL 9005)
Number of blades	5
Blade pitch	0°
Airflow direction	V
Direction of rotation	Clockwise, viewed toward rotor
Degree of protection	IP55
Insulation class	"F"
Moisture (F) / Environmental (H) protection class	H2
Ambient temperature note	Occasional start-up at temperatures between -40°C and -25°C is permitted. For continuous operation at ambient temperatures below -25°C (such as refrigeration applications), use must be made of a fan design with special low-temperature bearings.
Max. permitted ambient temp. for motor (transport/storage)	+80 °C
Min. permitted ambient temp. for motor (transport/storage)	-40 °C
Installation position	Shaft horizontal or rotor on bottom; rotor on top on request
Condensation drainage holes	On rotor side
Mode	S1
Motor bearing	Ball bearing
Technical features	<ul style="list-style-type: none"> <li>- Operation and alarm display with LED</li> <li>- External 15-50 VDC input (parameterization)</li> <li>- Alarm relay</li> <li>- Integrated PI controller</li> <li>- Configurable inputs/outputs (I/O)</li> <li>- MODBUS V6.0</li> <li>- Motor current limitation</li> <li>- RFID - ISO 15693 compatible</li> <li>- RS-485 MODBUS-RTU</li> <li>- Soft start</li> <li>- Voltage output 3.3-24 VDC, Pmax = 800 mW</li> <li>- Control interface with SELV potential safely disconnected from the mains</li> <li>- Thermal overload protection for electronics/motor</li> <li>- Line undervoltage / phase failure detection</li> </ul>
EMC immunity to interference	According to EN 61000-6-2 (industrial environment)
EMC interference emission	According to EN 61000-6-3 (household environment), except EN 61000-3-2 for professionally used equipment with a total rated power greater than 1 kW
Touch current according to IEC 60990 (measuring circuit Fig. 4, TN system)	<= 3.5 mA
Electrical hookup	Terminal box
Motor protection	Reverse polarity and locked-rotor protection
Protection class	I (with customer connection of protective earth)



W3G800-GU21-03

## EC axial fan - HyBlade

sickle-shaped blades (S series)

Fan housing with guard grille

<b>Conformity with standards</b>	EN 61800-5-1; CE
<b>Approval</b>	CSA C22.2 No. 77 + CAN/CSA-E60730-1; EAC; UL 1004-7 + 60730-1



# EC axial fan - HyBlade

sickle-shaped blades (S series)

Fan housing with guard grille

## Product drawing

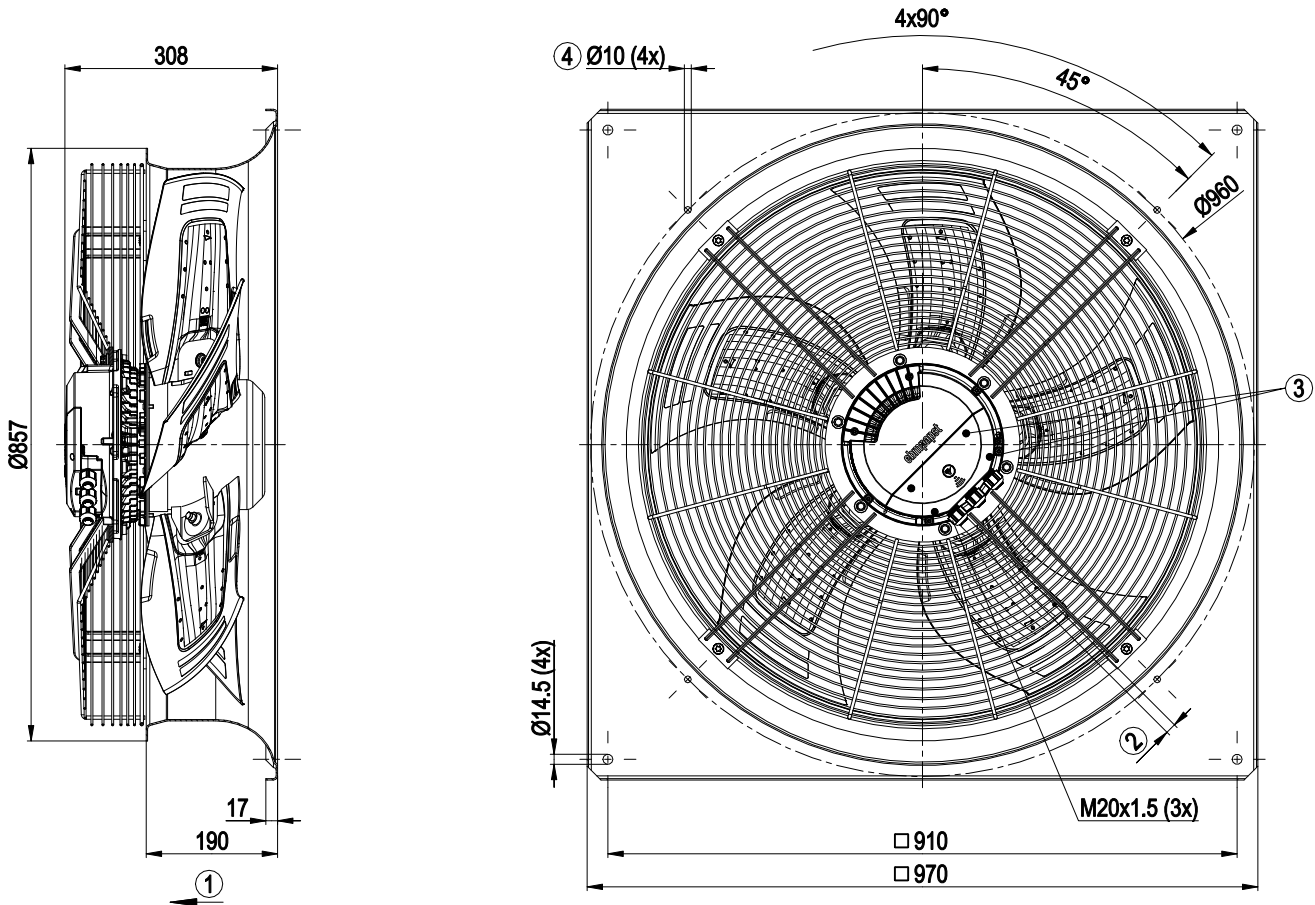

1	Airflow direction "V"
2	Cable diameter min. 4 mm, max. 10 mm, tightening torque $4 \pm 0.6$ Nm
3	Tightening torque $1.5 \pm 0.2$ Nm
4	Attachment holes for FlowGrid (80000-2-2957 not included in scope of delivery)



# EC axial fan - HyBlade

sickle-shaped blades (S series)

Fan housing with guard grille

## Connection diagram

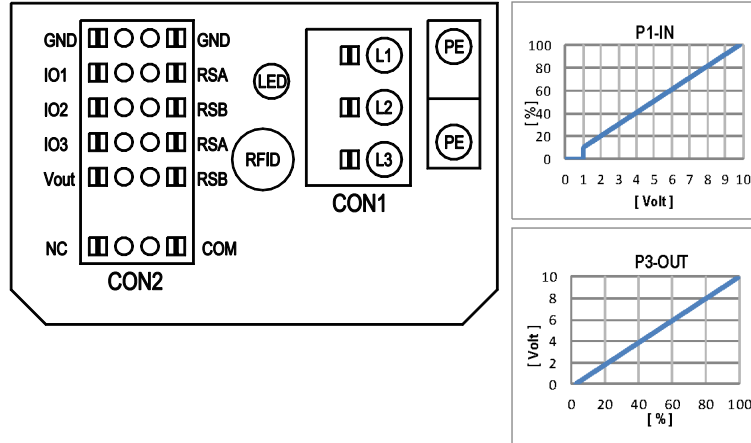

No.	Conn.	Designation	Function/assignment
	CON1	L1, L2, L3	Power supply, phase, see nameplate for voltage range
	PE	PE	Protective earth
	CON2	RSA	RS485 interface for MODBUS, RSA; SELV
	CON2	RSB	RS485 interface for MODBUS, RSB; SELV
	CON2	GND	Reference ground for control interface, SELV
	CON2	IO1	Function parameterizable (see "Optional interface functions" table) Factory setting: Digital input - high active, function: Disable input, SELV - inactive: Pin open or applied voltage < 1.5 VDC - active: applied voltage 3.5-50 VDC Reset function: Triggering of error reset on change of state from "enabled" to "disabled"
	CON2	IO2	Function parameterizable (see "Optional interface functions" table) Factory setting: Analog input 0-10 V / PWM, Ri=100 kΩ, function: Set value Characteristic curve parameterizable (see input characteristic curve P1-IN), SELV
	CON2	IO3	Function parameterizable (see "Optional interface functions" table) Factory setting: Analog output 0-10 V, max. 5 mA, function: Fan modulation level Characteristic curve parameterizable (see output characteristic curve P3-OUT), SELV
	CON2	Vout	Voltage output 3.3-24 VDC ±5%, Pmax=800 mW, voltage parameterizable Factory setting: 10 VDC short-circuit-proof, supply for external devices, SELV alternatively: 15-50 VDC input for parameterization via MODBUS without line voltage
	CON2	COM	Status relay, floating status contact, common connection, contact rating 250 VAC / 2 A (AC1) / min. 10 mA, reinforced insulation on supply side and on control interface side
	CON2	NC	Status relay, floating status contact, break for failure
		LED	green: status = good, ready for operation orange: status = warning red: status = failure
		P1-IN	Input characteristic curve
		P3-OUT	Output characteristic curve



# EC axial fan - HyBlade

sickle-shaped blades (S series)

Fan housing with guard grille

## Terminal/plug assignment

CON2	configurable IO mode	electrical specification	configurable IO functions: normal / inverse	MODBUS Register for IO mode configuration													
				D101 [..]	D104 [..]	D12E [..]	D148 [..]	D16C [..]	D16A [..]	(selected directly via IO mode)	(selected directly via IO mode)	D130 [0]	D130 [1]	D130 [2]	D130 [5]	D00C [1]	D130 [4]
101	o Din1 (active high): digital input	not active: pin open or applied voltage < 1.5VDC active: applied voltage 3.5-50VDC, SELV															
	o Ain1 0-10V/PWM: analog input	RI=100K, characteristic curve parameterizable, f <sub>PWM</sub> =1k..10KHz, SELV															
	o Tach out (open collector output)	U <sub>max</sub> =50VDC, I <sub>max</sub> =20mA, SELV															
	o Diagnostics out (open collector output)	U <sub>max</sub> =50VDC, I <sub>max</sub> =20mA, SELV															
102	o Din2 (active high): digital input	not active: pin open or applied voltage < 1.5VDC active: applied voltage 3.5-50VDC, SELV															
	o Ain2 0-10V/PWM: analog input	RI=100K, characteristic curve parameterizable, f <sub>PWM</sub> =1k..10KHz, SELV															
	o Ain2 4-20mA: analog input	RI=125R, characteristic curve parameterizable, SELV															
103	o Din3 (active high): digital input	not active: pin open or applied voltage < 1.5VDC active: applied voltage 3.5-50VDC, SELV															
	o Din3 (active low): digital input	not active: pin open or applied voltage < 1.5VDC active: applied voltage 3.5-50VDC, SELV															
	o PWMIn3: digital input	not active: pin open or applied voltage < 1.5VDC active: applied voltage < 1.5VDC, SELV 40Hz - 10KHz, characteristics parameterizable															
	o Aout3 0-10V: analog output	not active: pin open or applied voltage < 1.5VDC, SELV active: applied voltage < 1.5VDC, SELV function parameterizable, max. 5mA, max output frequency 300Hz, SELV															
Vout	o Tacho out (pulses): analog output	0-10V max. 5mA, max output frequency 300Hz, SELV															
	o Diagnostics out (pulses)	0-10V max. 5mA, max output frequency 300Hz, SELV															
	RSB	RS485 bus connection,	MODBUS RTU, specification V6.0, SELV														
RSA																	
Vout	voltage output	voltage parameterizable 3.3...24VDC +/- 5.5%, P <sub>max</sub> =800mW, short-circu.it-proof, supply for external devices, SELV	D16E [..]														
	alternatively: input auxiliary power supply for parameterization via RS485/MODBUS RTU without line voltage	15...50VDC															

o configurable option

For further information and additional functions see EC Control Software: Fan-Set-App. or MODBUS Parameter Specification V6.0



# EC axial fan - HyBlade

sickle-shaped blades (S series)

Fan housing with guard grille

## Curves: Air performance 50 Hz

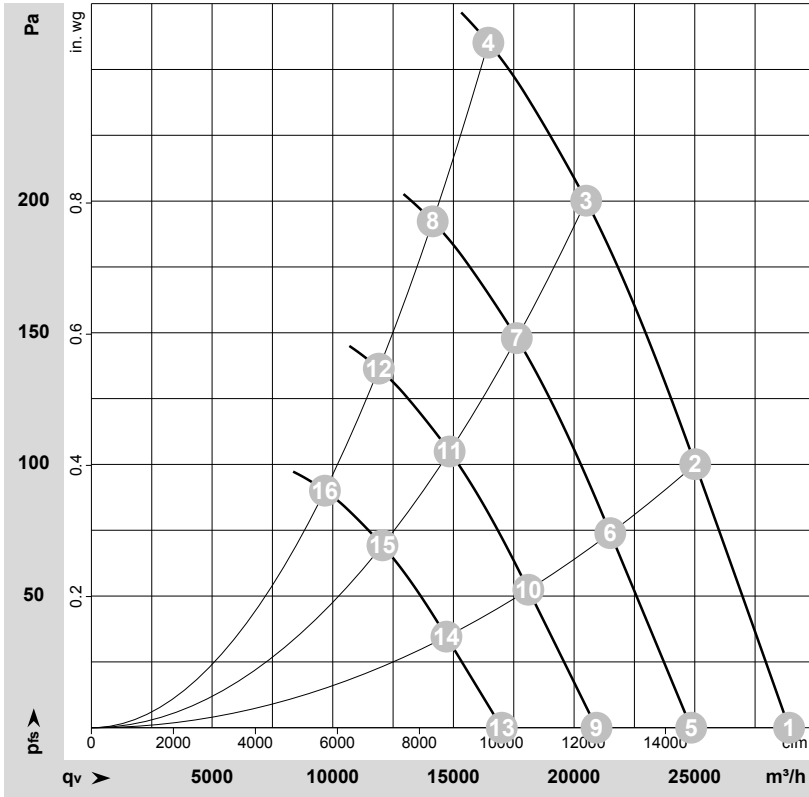

$\rho = 1.15 \text{ kg/m}^3 \pm 2 \%$

Measurement: LU-202121-1

Air performance measured according to ISO 5801 installation category A. For detailed information on the measurement setup, contact ebmpapst. Intake sound level: Sound power level according to ISO 13347 / sound pressure level measured at 1 m distance from fan axis. The values given are valid under the specified measuring conditions and may vary due to conditions of installation. For deviations from the standard configuration, the parameters have to be checked on the installed unit.

## Measured values

	Wired	U	f	n	P <sub>ed</sub>	I	LpA <sub>in</sub>	LwA <sub>in</sub>	LwA <sub>out</sub>	q <sub>v</sub>	p <sub>fs</sub>	q <sub>v</sub>	p <sub>fs</sub>
		V	Hz	min <sup>-1</sup>	W	A	dB(A)	dB(A)	dB(A)	m <sup>3</sup> /h	Pa	cfm	in. wg
1	3~	400	50	1100	2043	3.19	70	77	78	28910	0	17015	0.00
2	3~	400	50	1100	2410	3.73	70	77	77	25020	100	14725	0.40
3	3~	400	50	1100	2723	4.20	73	79	78	20500	200	12065	0.80
4	3~	400	50	1100	3025	4.60	77	84	83	16450	260	9680	1.04
5	3~	400	50	950	1298	2.03	66	73	74	24855	0	14630	0.00
6	3~	400	50	950	1529	2.37	67	73	73	21500	74	12655	0.30
7	3~	400	50	950	1731	2.67	69	76	74	17625	148	10375	0.59
8	3~	400	50	950	1882	2.89	73	80	80	14140	193	8325	0.77
9	3~	400	50	800	775	1.21	62	68	69	20930	0	12320	0.00
10	3~	400	50	800	913	1.41	62	69	69	18105	52	10655	0.21
11	3~	400	50	800	1033	1.59	65	71	70	14845	105	8735	0.42
12	3~	400	50	800	1124	1.73	69	76	75	11910	137	7010	0.55
13	3~	400	50	650	416	0.65	57	63	64	17005	0	10010	0.00
14	3~	400	50	650	490	0.76	57	63	63	14710	35	8660	0.14
15	3~	400	50	650	554	0.85	60	66	65	12060	69	7100	0.28
16	3~	400	50	650	603	0.93	64	71	70	9675	90	5695	0.36

Wired = Wiring · U = Voltage · f = Frequency · n = Speed (rpm) · P<sub>ed</sub> = Power consumption · I = Current draw · LpA<sub>in</sub> = Sound pressure level intake side · LwA<sub>in</sub> = Sound power level intake side · LwA<sub>out</sub> = Sound power level outlet side · q<sub>v</sub> = Air flow · p<sub>fs</sub> = Pressure increase

