

sickled blades (S series)

with full square nozzle, for agricultural ventilation

W3G800-DO81-35 ebmpapst Datasheet

sales@fansco.com

www.fansco.com

Nominal data

Type	W3G800-DO81-35	
Motor	M3G112-IA	
Phase		1~
Nominal voltage	VAC	230
Nominal voltage range	VAC	200 .. 277
Frequency	Hz	50/60
Type of data definition		ml
State		prelim.
Speed	min ⁻¹	710
Power input	W	730
Current draw	A	3.2
Max. back pressure	Pa	100
Min. ambient temperature	°C	-25
Max. ambient temperature	°C	50

ml = Max. load · me = Max. efficiency · fa = Running at free air · cs = Customer specs · cu = Customer unit
Subject to alterations

Data according to ErP directive

		Actual	Request 2013	Request 2015
Installation category	A			
Efficiency category	Static			
Variable speed drive	Yes			
Specific ratio*	1.00			
Overall efficiency η_{es}	%	43.7	28.6	32.6
Efficiency grade N		51.1	36	40
Power input P_{ed}	kW	0.68		
Air flow q_v	m ³ /h	11680		
Pressure increase p_{fs}	Pa	84		
Speed n	min ⁻¹	715		

Data definition with optimum efficiency. LU-121620
The ErP data is determined using a motor-impeller combination in a standardised measurement configuration.



Technical features

Mass	20 kg
Size	800 mm
Surface of rotor	Coated in black
Material of electronics housing	Die-cast aluminium, coated in black
Material of blades	Press-fitted, coated sheet steel blank, sprayed with PP plastic
Material of mounting ring	Steel, galvanised and coated in black plastic (RAL9005)
Material of wall ring	Sheet steel, galvanised and coated in black plastic (RAL 9005)
Number of blades	5
Direction of air flow	"A"
Direction of rotation	Counter-clockwise, seen on rotor
Type of protection	IP 54
Insulation class	"B"
Humidity class	F4-2
Max. permissible ambient motor temp. (transp./ storage)	+80 °C
Min. permissible ambient motor temp. (transp./storage)	-40 °C
Mounting position	Shaft horizontal or rotor on top; rotor on bottom on request
Condensate discharge holes	On the stator side
Operation mode	S1
Motor bearing	Ball bearing
Technical features	<ul style="list-style-type: none"> - Output 10 VDC, max. 10 mA - Output 20 VDC, max. 50 mA - Output for slave 0-10 V - Operation and alarm display - Direction of rotation selection counter-clockwise / clockwise - Input for sensor 0-10 V or 4-20 mA - External 24 V input (programming) - Alarm relay - Integrated PID controller - Motor current limit - PFC, active - RS485 MODBUS RTU - Soft start - Control input 0-10 VDC / PWM - Control interface with SELV potential safely disconnected from the mains - Over-temperature protected electronics / motor - Line undervoltage / phase failure detection
EMC interference immunity	Acc. to EN 61000-6-2 (industrial environment)
EMC harmonics	Acc. to EN 61000-3-2/3
EMC interference emission	Acc. to EN 61000-6-4 (industrial environment)
Touch current acc. IEC 60990 (measuring network Fig. 4, TN system)	<= 3.5 mA
Electrical leads	Via terminal box
Motor protection	Thermal overload protector (TOP) wired internally
Protection class	I (if protective earth is connected by customer)
Product conforming to standard	EN 61800-5-1; CE
Approval	EAC

EC axial fan - HyBlade®

sickled blades (S series)

with full square nozzle, for agricultural ventilation

Product drawing

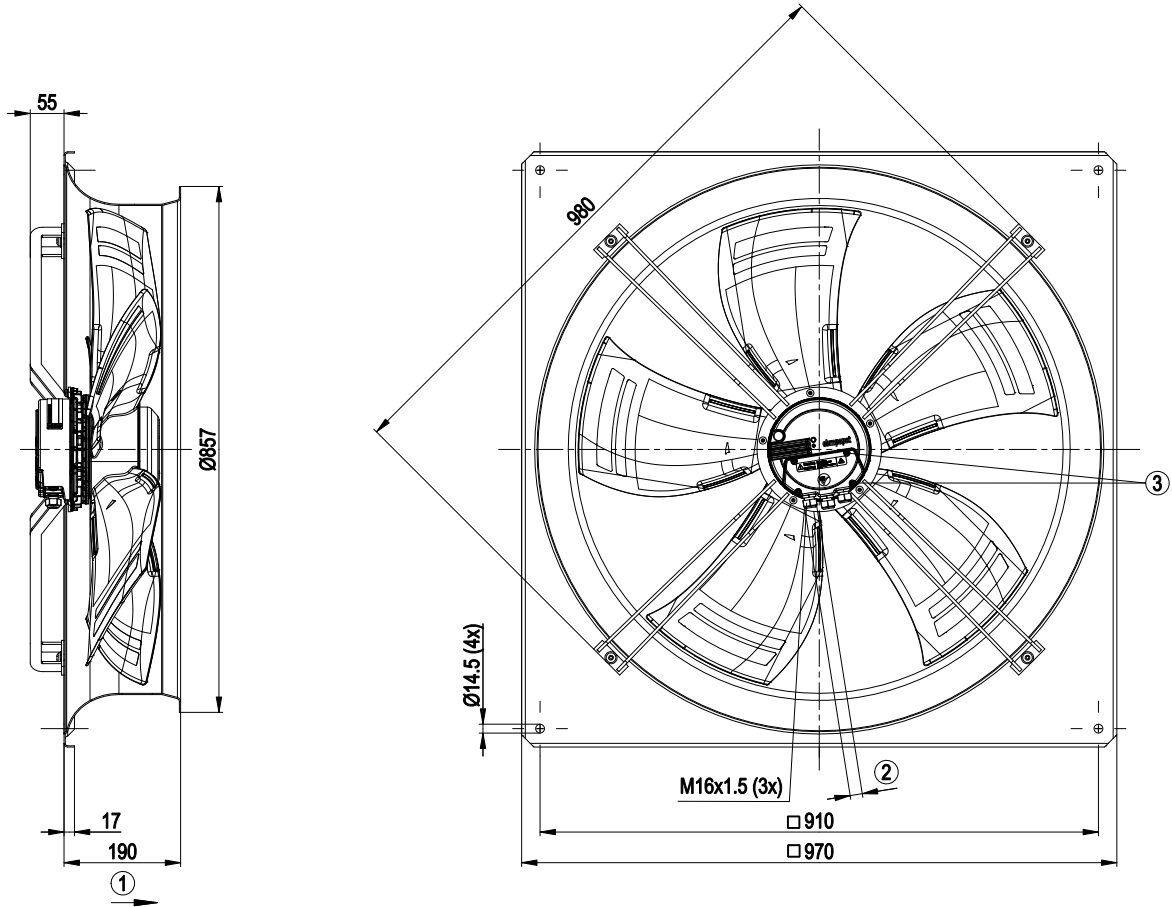

1	Direction of air flow "A"
2	Cable diameter min. 4 mm, max. 10 mm, tightening torque 2.5±0.4 Nm
3	Tightening torque 3.5±0.5 Nm



EC axial fan - HyBlade®

sickled blades (S series)

with full square nozzle, for agricultural ventilation

Connection screen

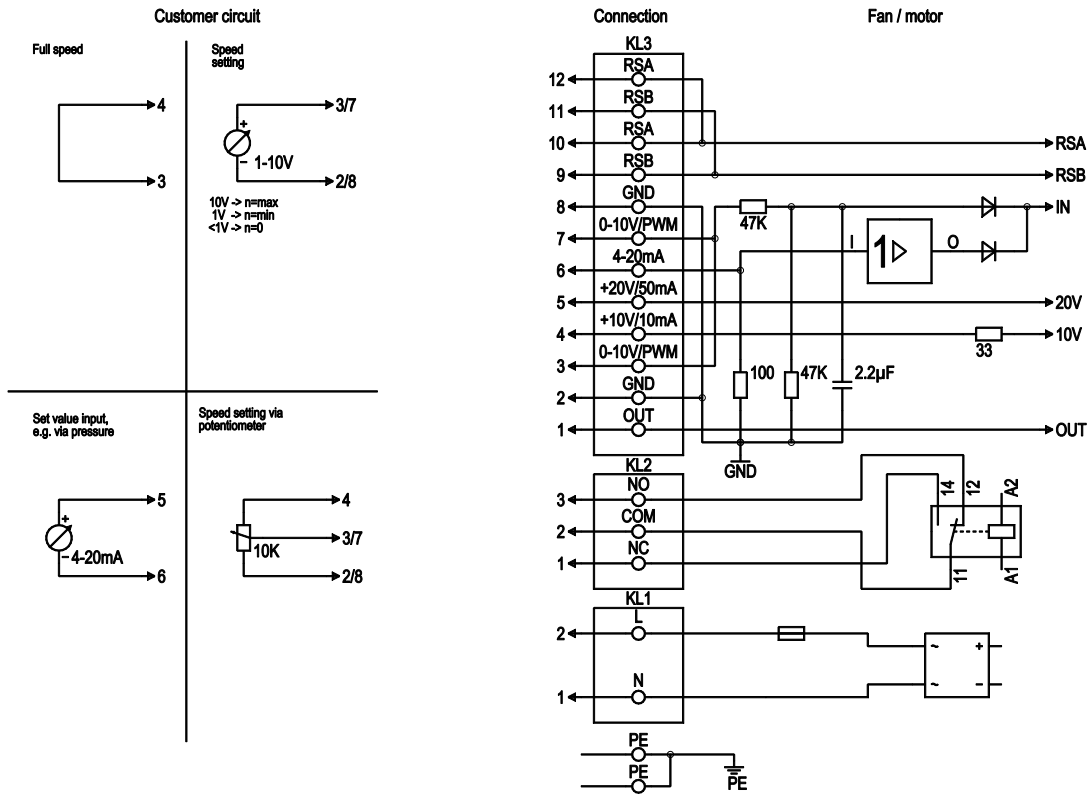

No.	Conn.	Designation	Function / assignment
PE	-	PE	Protective earth connection
KL1	1, 2	N, L	Supply voltage, 50/60 Hz
KL2	1	NC	Floating status message contact, break for failure
KL2	2	COM	Floating status message contact, changeover contact, common connection (2 A, max. 250 VAC, min. 10 mA, AC1)
KL2	3	NO	Floating status message contact, normally open, make for failure
KL3	1	OUT	Analogue output, 0-10 VDC, max. 3 mA, SELV, Output of the current motor level control coefficient: 1 V corresponds to 10% level control coefficient, 10 V correspond to 100% level control coefficient.
KL3	2, 8	GND	Reference mass for control interface, SELV
KL3	3, 7	0-10 V	Use control / actual value input 0-10 VDC, impedance 100 kΩ only as alternative to 4-20 mA input, SELV
KL3	4	+10 V	Voltage output 10 VDC (+/- 3%), max. 10 mA, Supply voltage for ext. devices (e.g. potentiometer), SELV
KL3	5	+20 V	Voltage output 20 VDC (+25%/-10%), max. 50 mA Supply voltage for ext. devices (e.g. sensors), SELV
KL3	6	4-20 mA	Use control / actual value input 4-20 mA, impedance 100 Ω, only as alternative to 0-10 V input, SELV
KL3	9, 11	RSB	RS485 interface for MODBUS, RSB
KL3	10, 12	RSA	RS485 interface for MODBUS, RSA



Charts: Air flow 50 Hz

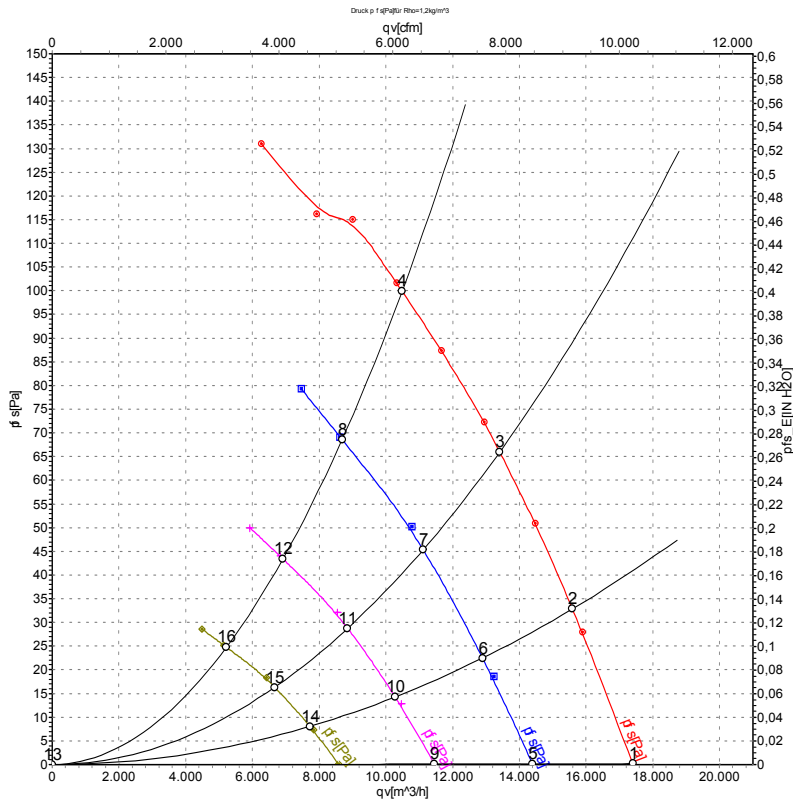

Measurement: LU-121620
 Measurement: LU-121634
 Measurement: LU-121635
 Measurement: LU-121636

Air performance measured as per ISO 5801 Installation category A. For detailed information on the measuring set-up, please contact ebm-papst. Suction-side noise levels: LwA measured as per ISO 13347 / LpA measured with 1m distance to fan axis. The values given are valid under the measuring conditions mentioned above and may vary according to the actual installation situation. With any deviation from the standard set-up, the specific values have to be checked and reviewed with the unit installed.

Measured values

	U	f	n	P _{ed}	I	LpA _{in}	LwA _{in}	LwA _{out}	qv	p _{fs}
	V	Hz	min ⁻¹	W	A	dB(A)	dB(A)	dB(A)	m ³ /h	Pa
1	230	50	710	462	2.15	63	70	70	17400	0
2	230	50	710	549	2.51	60	66	66	15590	33
3	230	50	710	634	2.86	58	65	64	13410	66
4	230	50	710	730	3.20	61	69	69	10490	100
5	230	50	590	264	1.25	59	65	65	14390	0
6	230	50	590	309	1.44	56	62	62	12890	23
7	230	50	590	352	1.64	54	60	60	11120	46
8	230	50	590	395	1.84	57	64	64	8690	69
9	230	50	470	188	0.69	54	60	60	11450	0
10	230	50	470	164	0.78	51	57	57	10270	15
11	230	50	470	186	0.88	49	55	55	8850	29
12	230	50	470	208	0.98	50	58	57	6910	44
13	230	50	355	138	0.74	44	53	54	0	60
14	230	50	355	81	0.46	45	51	51	7715	8
15	230	50	355	90	0.51	43	49	49	6670	16
16	230	50	355	98	0.55	43	50	50	5220	25

U = Supply voltage · f = Frequency · n = Speed · P_{ed} = Power input · I = Current draw · LpA_{in} = Sound pressure level inlet side · LwA_{in} = Sound power level inlet side · LwA_{out} = Sound power level outlet side
 qv = Air flow · p_{fs} = Pressure increase

