

EC axial fan - HyBlade

sickle-shaped blades (S series)

with square full nozzle

W3G710-GO81-01 ebmpapst Datasheet

sales@fansco.com

www.fansco.com

Limited partnership · Headquarters Muldingen

Amtsgericht (court of registration) Stuttgart · HRA 590344

General partner Elektrobau Muldingen GmbH · Headquarters Muldingen

Amtsgericht (court of registration) Stuttgart · HRB 590142

Nominal data

Type	W3G710-GO81-01	
Motor	M3G112-IA	
Phase		3~
Nominal voltage	VAC	400
Nominal voltage range	VAC	380 .. 480
Frequency	Hz	50/60
Method of obtaining data		ml
Speed (rpm)	min ⁻¹	900
Power consumption	W	930
Current draw	A	1.5
Max. back pressure	Pa	125
Max. back pressure	in. wg	0.5
Min. ambient temperature	°C	-25
Max. ambient temperature	°C	60

ml = Max. load · me = Max. efficiency · fa = Free air · cs = Customer specification · ce = Customer equipment
Subject to change

Data according to Commission Regulation (EU) 327/2011

		Actual	Req. 2015			
01 Overall efficiency η_{es}	%	41.9	33.3	09 Power consumption P_{ed}	kW	0.86
02 Measurement category		A		09 Air flow q_v	m ³ /h	11370
03 Efficiency category		Static		09 Pressure increase p_{fs}	Pa	105
04 Efficiency grade N		48.6	40	10 Speed (rpm) n	min ⁻¹	905
05 Variable speed drive		Yes		11 Specific ratio*		1.00

Data obtained at optimum efficiency level.

The ErP data is determined using a motor-impeller combination in a standardized measurement setup.

* Specific ratio = $1 + p_s / 100\,000\text{ Pa}$

LU-117117



Technical description

Weight	27.2 kg
Size	710 mm
Motor size	112
Rotor surface	Painted black
Electronics housing material	Die-cast aluminum
Blade material	Sheet aluminum insert, sprayed with PP plastic
Fan housing material	Sheet steel, pre-galvanized and coated with black plastic (RAL 9005)
Guard grille material	Steel, coated with black plastic (RAL 9005)
Number of blades	5
Blade pitch	0°
Airflow direction	V
Direction of rotation	Counterclockwise, viewed toward rotor
Degree of protection	IP54
Insulation class	"B"
Moisture (F) / Environmental (H) protection class	H2
Max. permitted ambient temp. for motor (transport/storage)	+80 °C
Min. permitted ambient temp. for motor (transport/storage)	-40 °C
Installation position	Shaft horizontal or rotor on bottom; rotor on top on request
Condensation drainage holes	On rotor side
Mode	S1
Motor bearing	Ball bearing
Technical features	<ul style="list-style-type: none"> - Output 10 VDC, max. 10 mA - Alarm relay - Integrated PID controller - Motor current limitation - PFC, passive - Soft start - Control input 0-10 VDC / PWM - Control interface with SELV potential safely disconnected from supply - Thermal overload protection for electronics/motor - Line undervoltage / phase failure detection
EMC immunity to interference	According to EN 61000-6-2 (industrial environment)
EMC circuit feedback	According to EN 61000-3-2/3
EMC interference emission	According to EN 61000-6-4 (industrial environment)
Touch current according to IEC 60990 (measuring circuit Fig. 4, TN system)	<= 3.5 mA
Motor protection	Thermal overload protector (TOP) internally connected
With cable	Variable
Protection class	I (with customer connection of protective earth)
Conformity with standards	EN 61800-5-1; CE
Approval	CCC; EAC

EC axial fan - HyBlade

sickle-shaped blades (S series)

with square full nozzle

Product drawing

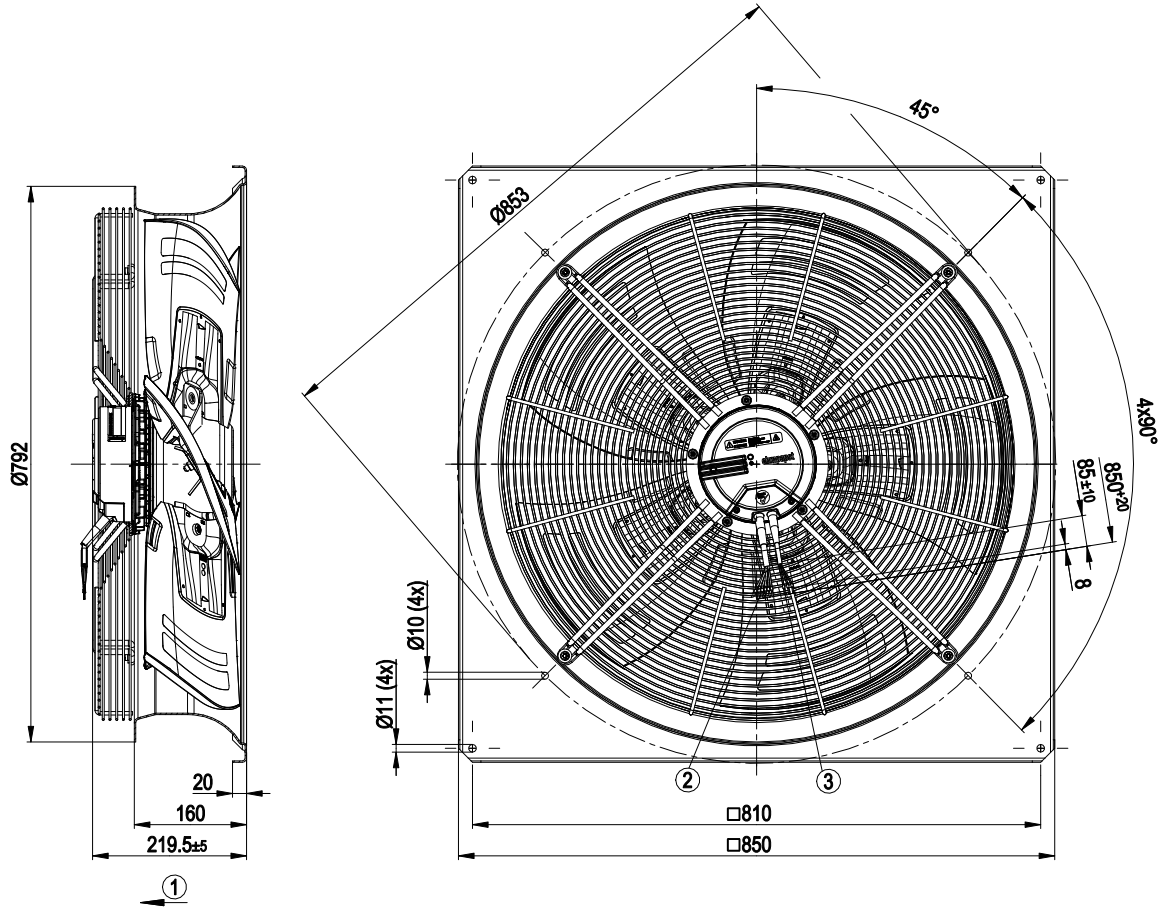

1	Direction of air flow "V"
2	Cable PVC AWG18, 6x crimped ferrules
3	Cable PVC AWG22, 3x crimped ferrules



EC axial fan - HyBlade

sickle-shaped blades (S series)

with square full nozzle

Connection diagram

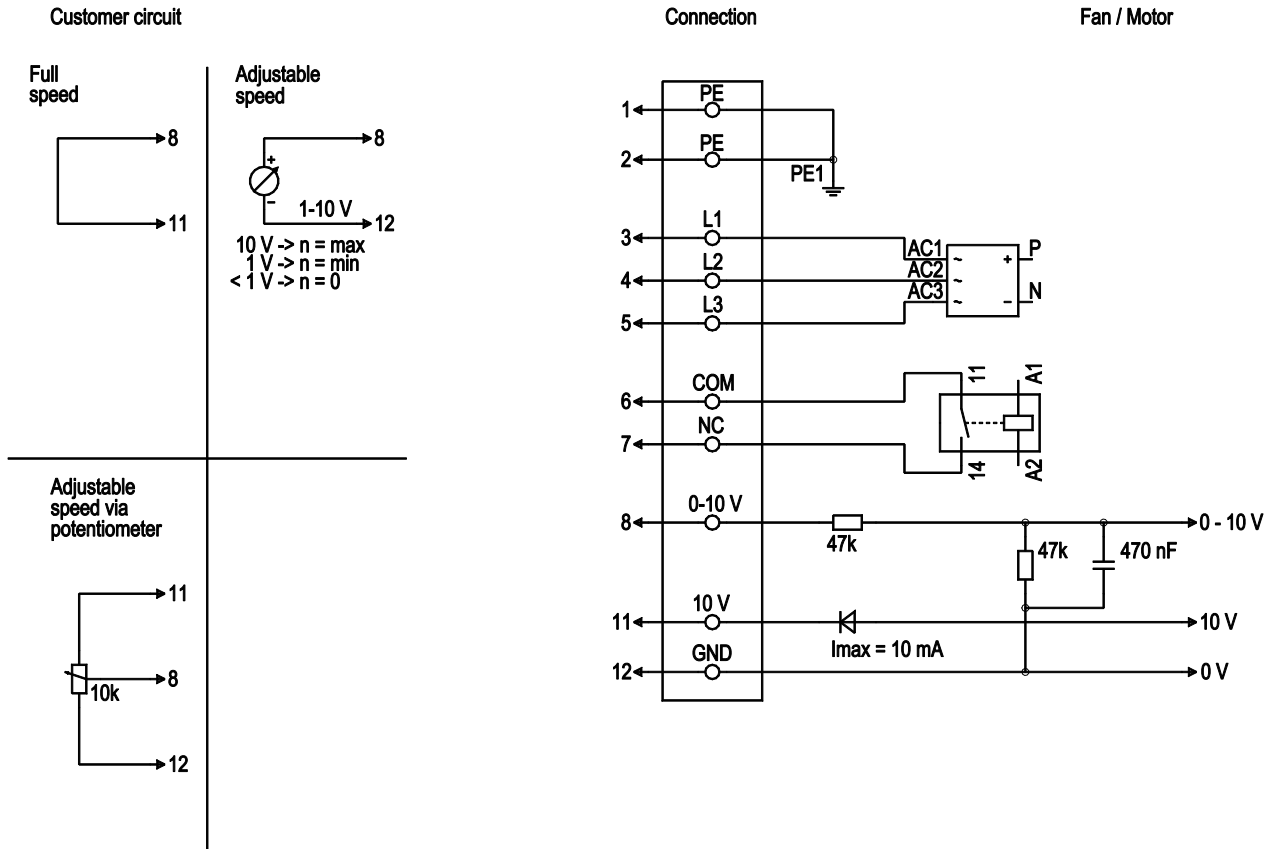

No.	Conn.	Designation	Color	Function/assignment
1	1, 2	PE	green/yellow	Protective earth
1	3, 4, 5	L1, L2, L3	black	Power supply 50 / 60 Hz
1	6	COM	white 1	Floating status contact, break for failure (2A, max. 250 VAC, min. 10 mA, AC1)
1	7	NC	white 2	Floating status contact, break for failure
2	8	0 - 10 V	yellow	Control input, set value 0-10 VDC, impedance 100 kOhm, SELV
2	11	+ 10 V	red	Voltage output 10 VDC (±3%), max. 10 mA, power supply for external devices (e.g. potentiometers), SELV
2	12	GND	blue	Reference ground for control interface, SELV



EC axial fan - HyBlade

sickle-shaped blades (S series)

with square full nozzle

Curves: Air performance 50 Hz

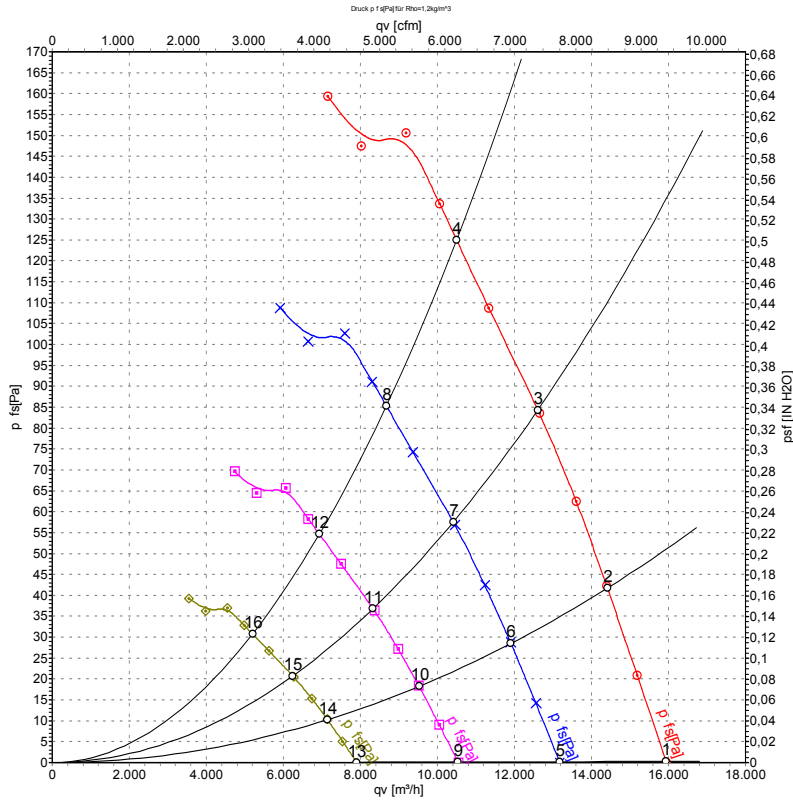

Measurement: LU-123826-1

Air performance measured according to ISO 5801 installation category A. For detailed information on the measurement setup, contact ebm-papst. Intake sound level: Sound power level according to ISO 13347 / sound pressure level measured at 1 m distance from fan axis. The values given are valid under the specified measuring conditions and may vary due to conditions of installation. For deviations from the standard configuration, the parameters have to be checked on the installed unit.

Measured values

	U	f	n	P _{ed}	I	LpA _{in}	LwA _{in}	LwA _{out}	q _v	P _{fs}	q _v	P _{fs}
	V	Hz	min ⁻¹	W	A	dB(A)	dB(A)	dB(A)	m ³ /h	Pa	cfm	in. wg
1	400	50	900	602	1.02	64	70	71	15940	0	9380	0.00
2	400	50	900	718	1.17	63	69	69	14420	42	8485	0.17
3	400	50	900	827	1.30	63	70	70	12610	85	7420	0.34
4	400	50	900	930	1.50	69	75	75	10500	125	6180	0.50
5	400	50	750	340	0.58	60	66	67	13170	0	7750	0.00
6	400	50	750	405	0.66	59	65	65	11910	29	7010	0.12
7	400	50	750	465	0.73	59	65	66	10410	58	6125	0.23
8	400	50	750	523	0.82	65	71	71	8670	85	5105	0.34
9	400	50	600	174	0.30	55	61	62	10540	0	6205	0.00
10	400	50	600	208	0.34	54	60	60	9530	18	5610	0.07
11	400	50	600	238	0.38	54	61	61	8330	37	4900	0.15
12	400	50	600	268	0.42	60	66	66	6940	55	4085	0.22
13	400	50	450	73	0.12	49	55	55	7905	0	4650	0.00
14	400	50	450	88	0.14	47	54	54	7145	10	4205	0.04
15	400	50	450	100	0.16	48	54	55	6245	21	3675	0.08
16	400	50	450	113	0.18	54	60	60	5205	31	3060	0.12

U = Voltage · f = Frequency · n = Speed (rpm) · P_{ed} = Power consumption · I = Current draw · LpA_{in} = Sound pressure level intake side · LwA_{in} = Sound power level intake side
 LwA_{out} = Sound power level outlet side · q_v = Air flow · P_{fs} = Pressure increase

