

W3G630-NP04-M1 ebmpapst Datasheet

sales@fansco.com

www.fansco.com

## Nominal data

Type	W3G630-NP04-M1	
Motor	M3G084-GF	
Phase		3~
Nominal voltage	VAC	400
Nominal voltage range	VAC	380 .. 480
Frequency	Hz	50/60
Method of obtaining data		ml
Speed (rpm)	min <sup>-1</sup>	840
Power consumption	W	450
Current draw	A	0.7
Max. back pressure	Pa	115
Max. back pressure	in. wg	0.46
Min. ambient temperature	°C	-40
Max. ambient temperature	°C	60

ml = Max. load · me = Max. efficiency · fa = Free air · cs = Customer specification · ce = Customer equipment  
Subject to change

## Data according to Commission Regulation (EU) 327/2011 (prEN 17166)

		Actual	Req. 2015			
01 Overall efficiency $\eta_{es}$	%	47.6	31.2	09 Power consumption $P_{ed}$	kW	0.39
02 Measurement category		A		09 Air flow $q_v$	m <sup>3</sup> /h	6945
03 Efficiency category		Static		09 Pressure increase $p_{fs}$	Pa	89
04 Efficiency grade N		56.4	40	10 Speed (rpm) n	min <sup>-1</sup>	845
05 Variable speed drive		Yes		11 Specific ratio*		1.00

Data obtained at optimum efficiency level.

\* Specific ratio =  $1 + p_s / 100\,000\text{ Pa}$ 

LU-204304

The efficiency values displayed for achieving conformity with the Ecodesign Regulation EU 327/2011 has been reached with defined air duct components (e.g. inlet rings).  
The dimensions must be requested from ebm-papst. If other air conduction geometries are used on the installation side, the ebm-papst evaluation loses its validity/the conformity must be confirmed again.  
The product does not fall within the scope of Regulation (EU) 2019/1781 due to the exception specified in Article 2 (2a) (motors completely integrated into a product).



### Technical description

Size	630 mm
Motor size	84
Rotor surface	Painted black
Terminal box material	PP plastic
Electronics housing material	Die-cast aluminum, painted black
Impeller material	PP plastic
Fan housing material	Sheet steel, galvanized and coated with black plastic (RAL 9005)
Guard grille material	Steel, coated with black plastic (RAL 9005)
Number of blades	5
Blade pitch	0°
Airflow direction	V
Direction of rotation	Clockwise, viewed toward rotor
Degree of protection	IP55
Insulation class	"F"
Moisture (F) / Environmental (H) protection class	H2
Ambient temperature note	Occasional start-up at temperatures between -40°C and -25°C is permitted. For continuous operation at ambient temperatures below -25°C (such as refrigeration applications), use must be made of a fan design with special low-temperature bearings.
Max. permitted ambient temp. for motor (transport/storage)	+80 °C
Min. permitted ambient temp. for motor (transport/storage)	-40 °C
Installation position	Shaft horizontal or rotor on bottom; rotor on top on request
Condensation drainage holes	On rotor side
Mode	S1
Motor bearing	Ball bearing; (sealed)
Technical features	<ul style="list-style-type: none"> <li>- Output 10 VDC, max. 10 mA</li> <li>- Operation and alarm display</li> <li>- External 24 V input (parameter setting)</li> <li>- Alarm relay</li> <li>- Integrated PID controller</li> <li>- Motor current limitation</li> <li>- PFC, passive</li> <li>- RS-485 MODBUS-RTU</li> <li>- Soft start</li> <li>- EEPROM write cycles: 100,000 maximum</li> <li>- Control input 0-10 VDC / PWM</li> <li>- Control interface with SELV potential safely disconnected from the mains</li> <li>- Thermal overload protection for electronics/motor</li> <li>- Line undervoltage / phase failure detection</li> </ul>
EMC immunity to interference	According to EN 61000-6-2 (industrial environment)
EMC circuit feedback	According to EN 61000-3-2/3
EMC interference emission	According to EN 61000-6-3 (household environment)
Touch current according to IEC 60990 (measuring circuit Fig. 4, TN system)	<= 3.5 mA
Electrical hookup	Terminal box
Motor protection	Thermal switch auto reset, internally connected

# EC axial fan - AxiBlade

sickle-shaped blades (S series)

Fan housing with guard grille

<b>Protection class</b>	I (with customer connection of protective earth)
<b>Conformity with standards</b>	EN 61800-5-1; CE
<b>Approval</b>	CSA C22.2 No. 77 + CAN/CSA-E60730-1; EAC; UL 1004-7 + 60730-1
<b>Comment</b>	Conformity with standard EN 60335-1 on request



# EC axial fan - AxiBlade

sickle-shaped blades (S series)

Fan housing with guard grille

## Product drawing

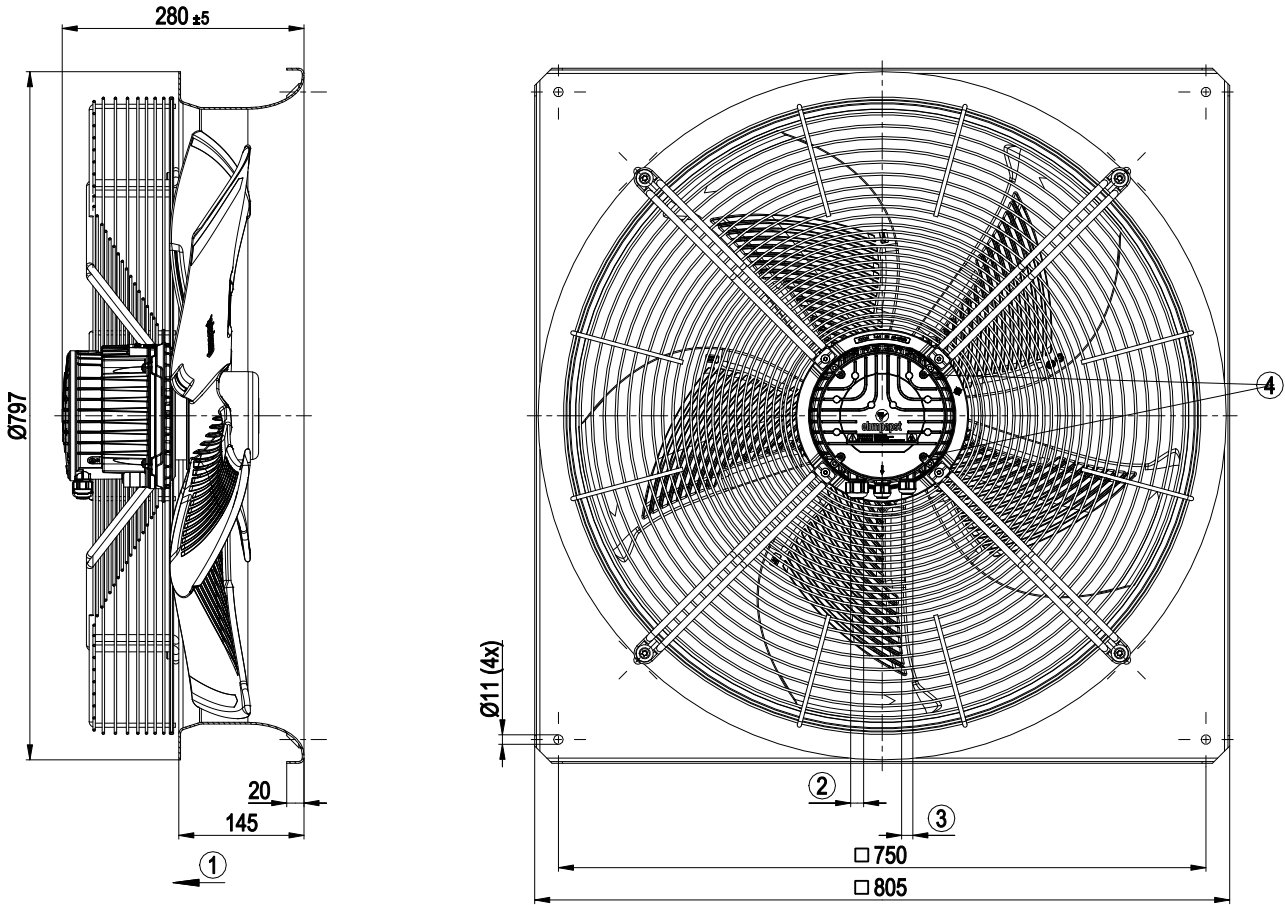

1	Airflow direction "V"
2	Cable diameter min. 8 mm, max. 12 mm, tightening torque 1.8±0.3 Nm (use must be made of seal provided) Cable diameter min. 4 mm, max. 10 mm, tightening torque 1.8±0.3 Nm
3	Cable diameter min. 6 mm, max. 10 mm, tightening torque 1.8±0.3 Nm (use must be made of seal provided) Cable diameter min. 4 mm, max. 7 mm, tightening torque 1.8±0.3 Nm
4	Tightening torque 1.5 ± 0.2 Nm



## Mounting dimensions

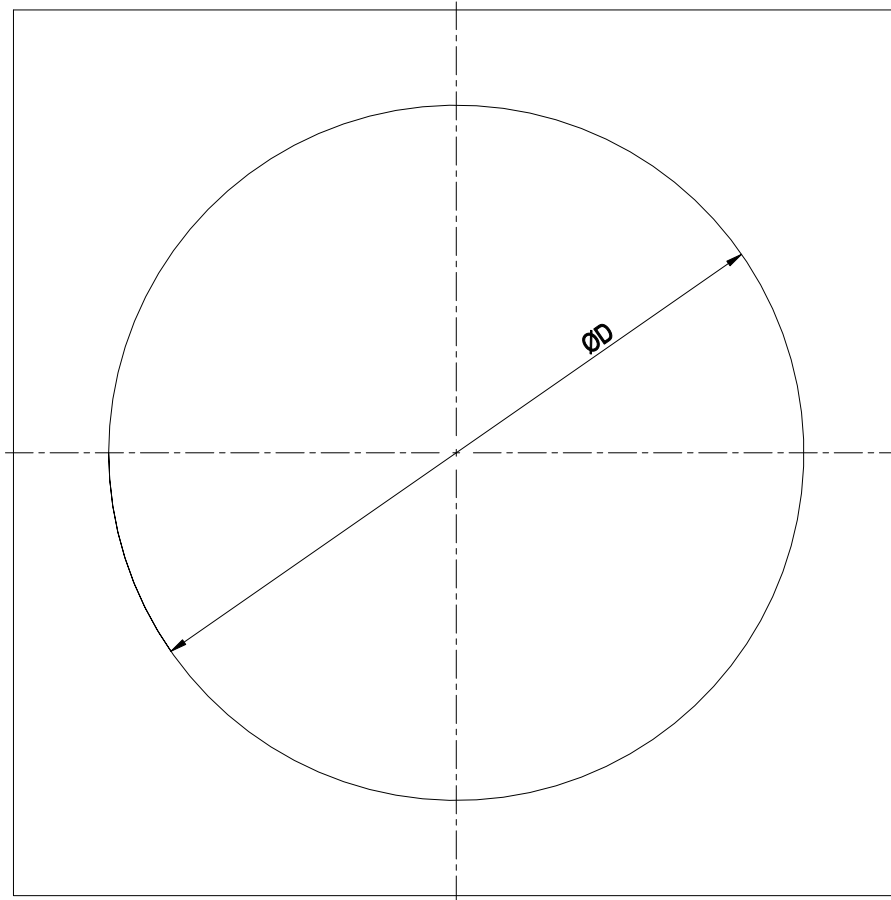

Diameter of the necessary recess for mounting the fan housing in the end device

BG630: D = Ø785 mm

BG710: D = Ø830 mm

BG800: D = Ø950 mm

BG910: D = Ø1050 mm

# EC axial fan - AxiBlade

sickle-shaped blades (S series)

Fan housing with guard grille

## Connection diagram

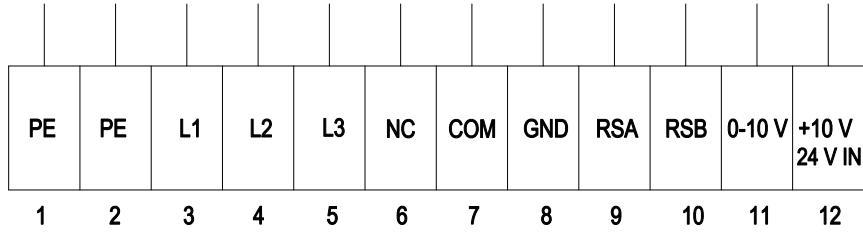

No.	Conn.	Designation	Function/assignment
1	PE	PE	Protective earth
2	PE	PE	Protective earth
3	L1	L1	Power supply
4	L2	L2	Power supply
5	L3	L3	Power supply
6	NC	NC	Status relay, floating status contact, break for failure, contact rating 250 VAC / 2 A (AC1) / min. 10 mA; reinforced insulation on supply side and basic insulation on control interface side
7	COM	COM	Status relay, floating status contact, break for failure, contact rating 250 VAC / 2 A (AC1) / min. 10 mA; reinforced insulation on supply side and basic insulation on control interface side
8	GND	GND	Reference ground for control interface, SELV
9	RSA	RSA	RS485 interface for MODBUS, RSA; SELV
10	RSB	RSB	RS485 interface for MODBUS, RSB; SELV
11	0-10 V	0-10 V	Analog input (set value) SELV, 0-10 V, Ri = 100 kΩ, adjustable curve
12	+10 V	+10 V	Fixed voltage output 10 VDC, SELV, +10 V ±3%, max. 10 mA, short-circuit-proof, power supply for external devices (e.g. pot); fixed voltage input 24 VDC for setting parameters via MODBUS without line voltage supply



## Curves: Air performance 50 Hz

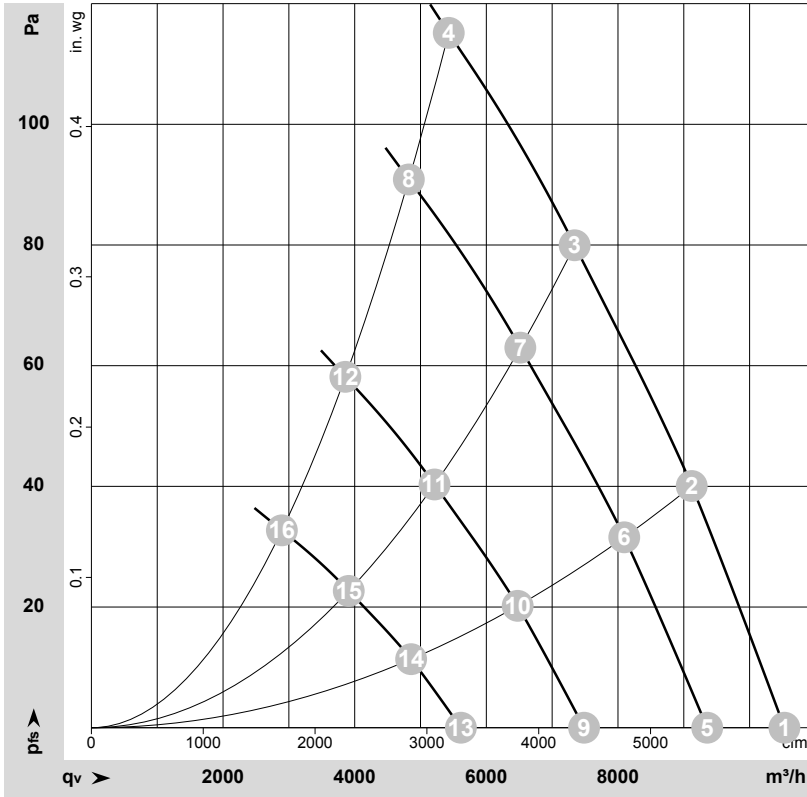

$\rho = 1.15 \text{ kg/m}^3 \pm 2 \%$

Measurement: LU-204304-1

Air performance measured according to ISO 5801 installation category A. For detailed information on the measurement setup, contact ebmpapst. Intake sound level: Sound power level according to ISO 13347 / sound pressure level measured at 1 m distance from fan axis. The values given are valid under the specified measuring conditions and may vary due to conditions of installation. For deviations from the standard configuration, the parameters have to be checked on the installed unit.

## Measured values

	Wired	U	f	n	P <sub>ed</sub>	I	LpA <sub>in</sub>	LwA <sub>in</sub>	LwA <sub>out</sub>	q <sub>v</sub>	P <sub>fs</sub>	q <sub>v</sub>	P <sub>fs</sub>
		V	Hz	min <sup>-1</sup>	W	A	dB(A)	dB(A)	dB(A)	m <sup>3</sup> /h	Pa	cfm	in. wg
1	3~	400	50	840	240	0.44	64	70	71	10530	0	6195	0.00
2	3~	400	50	840	318	0.55	61	67	67	9120	40	5370	0.16
3	3~	400	50	840	386	0.64	62	68	68	7340	80	4320	0.32
4	3~	400	50	840	450	0.70	68	75	75	5430	115	3195	0.46
5	3~	400	50	750	169	0.31	61	67	68	9355	0	5505	0.00
6	3~	400	50	750	223	0.38	58	64	64	8095	32	4765	0.13
7	3~	400	50	750	270	0.45	59	65	65	6515	63	3835	0.25
8	3~	400	50	750	318	0.52	65	72	72	4825	91	2840	0.37
9	3~	400	50	600	86	0.16	55	61	62	7485	0	4405	0.00
10	3~	400	50	600	114	0.20	52	58	59	6475	20	3810	0.08
11	3~	400	50	600	138	0.23	53	60	60	5215	40	3070	0.16
12	3~	400	50	600	163	0.26	59	67	67	3860	58	2270	0.23
13	3~	400	50	450	36	0.07	48	54	55	5615	0	3305	0.00
14	3~	400	50	450	48	0.08	45	51	51	4855	11	2860	0.04
15	3~	400	50	450	58	0.10	46	52	52	3910	23	2300	0.09
16	3~	400	50	450	69	0.11	52	59	59	2895	33	1705	0.13

Wired = Wiring · U = Voltage · f = Frequency · n = Speed (rpm) · P<sub>ed</sub> = Power consumption · I = Current draw · LpA<sub>in</sub> = Sound pressure level intake side · LwA<sub>in</sub> = Sound power level intake side  
 LwA<sub>out</sub> = Sound power level outlet side · q<sub>v</sub> = Air flow · P<sub>fs</sub> = Pressure increase

