

EC axial fan - HyBlade®

sickled blades (S series)

Wall ring with guard grille

W3G630-GD03-A1 ebmpapst Datasheet

sales@fansco.com

www.fansco.com

Nominal data

Type	W3G630-GD03-A1	
Motor	M3G084-GF	
Phase		1~
Nominal voltage	VAC	230
Nominal voltage range	VAC	200 .. 277
Frequency	Hz	50/60
Type of data definition		ml
Speed	min ⁻¹	800
Power input	W	280
Current draw	A	1.2
Max. back pressure	Pa	75
Min. ambient temperature	°C	-25
Max. ambient temperature	°C	60

ml = Max. load · me = Max. efficiency · fa = Running at free air · cs = Customer specs · cu = Customer unit
Subject to alterations

Data according to ErP directive

Installation category	A
Efficiency category	Static
Variable speed drive	Yes
Specific ratio*	1.00

* Specific ratio = $1 + p_b / 100\,000\text{ Pa}$

		Actual	Request 2013	Request 2015
Overall efficiency η_{es}	%	42.3	25.8	29.8
Efficiency grade N		52.5	36	40
Power input P_{ed}	kW	0.24		
Air flow q_v	m ³ /h	6570		
Pressure increase p_{fs}	Pa	52		
Speed n	min ⁻¹	805		

Data definition with optimum efficiency. LU-126911
The ErP data is determined using a motor-impeller combination in a standardised measurement configuration.



Technical features

Mass	19.6 kg
Size	630 mm
Surface of rotor	Coated in black
Material of blades	Press-fitted sheet steel blank, sprayed with PP plastic
Material of wall ring	Sheet steel, pre-galvanised and coated in black plastic (RAL 9005)
Material of guard grille	Steel, coated in black plastic (RAL9005)
Number of blades	5
Direction of air flow	"V"
Direction of rotation	Counter-clockwise, seen on rotor
Type of protection	IP 54; Depending on installation and position
Insulation class	"B"
Humidity class	F3-1
Max. permissible ambient motor temp. (transp./ storage)	+80 °C
Min. permissible ambient motor temp. (transp./storage)	-40 °C
Mounting position	Shaft horizontal or rotor on bottom; rotor on top on request
Condensate discharge holes	Rotor-side
Operation mode	S1
Motor bearing	Ball bearing
Technical features	<ul style="list-style-type: none"> - Output 10 VDC, max. 10 mA - Alarm relay - Motor current limit - PFC, active - Soft start - Control input 0-10 VDC / PWM - Control interface with SELV potential safely disconnected from the mains - Over-temperature protected electronics / motor - Line undervoltage / phase failure detection
EMC interference immunity	Acc. to EN 61000-6-2 (industrial environment)
EMC harmonics	Acc. to EN 61000-3-2/3
EMC interference emission	Acc. to EN 55022 (Class B, household environment)
Touch current acc. IEC 60990 (measuring network Fig. 4, TN system)	<= 3.5 mA
Motor protection	Thermal overload protector (TOP) wired internally
Cable exit	Variable
Protection class	I (if protective earth is connected by customer)
Product conforming to standard	EN 61800-5-1
Approval	EAC

EC axial fan - HyBlade®

sickled blades (S series)

Wall ring with guard grille

Product drawing

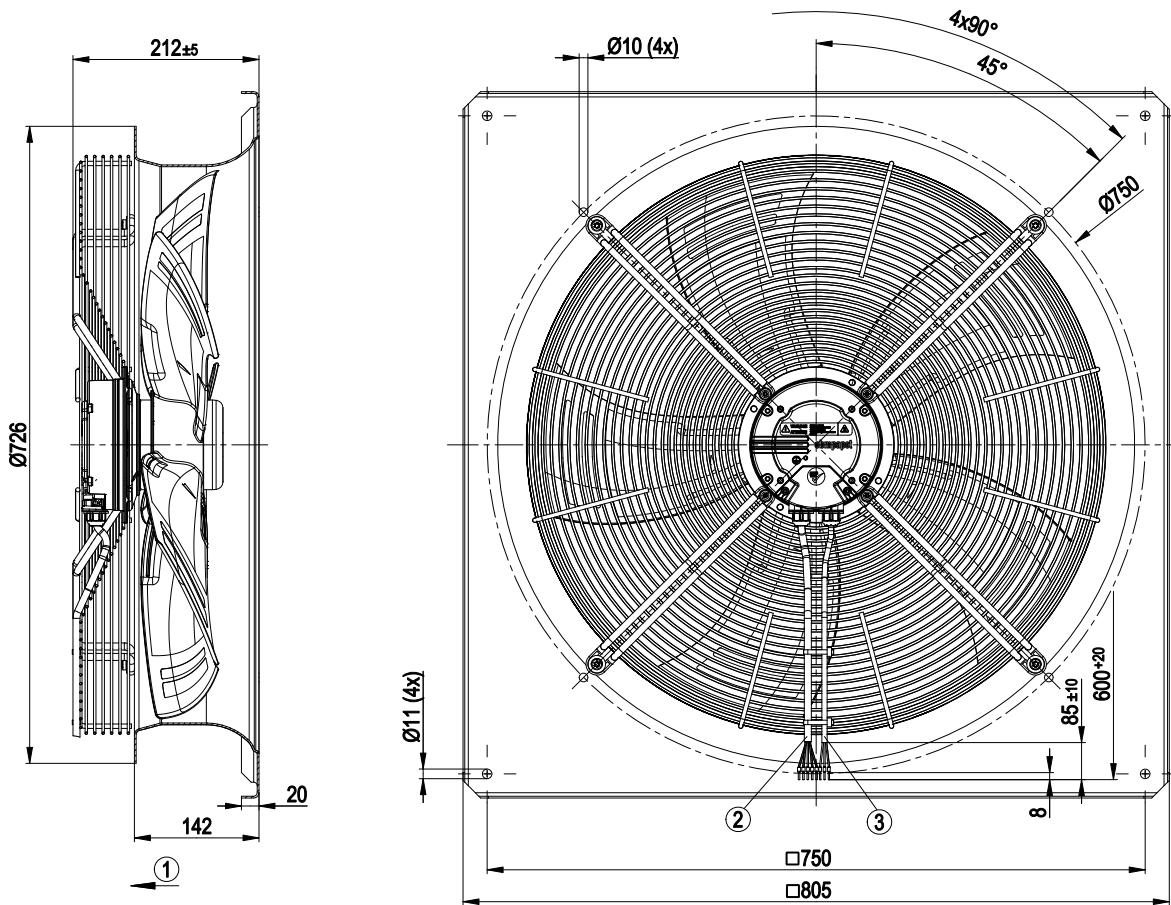

- | | |
|---|--|
| 1 | Direction of air flow "V" |
| 2 | Connection line PVC AWG18, 5x crimped core-end sleeves |
| 3 | Connection line PVC AWG22, 3x crimped core-end sleeves |



Connection screen

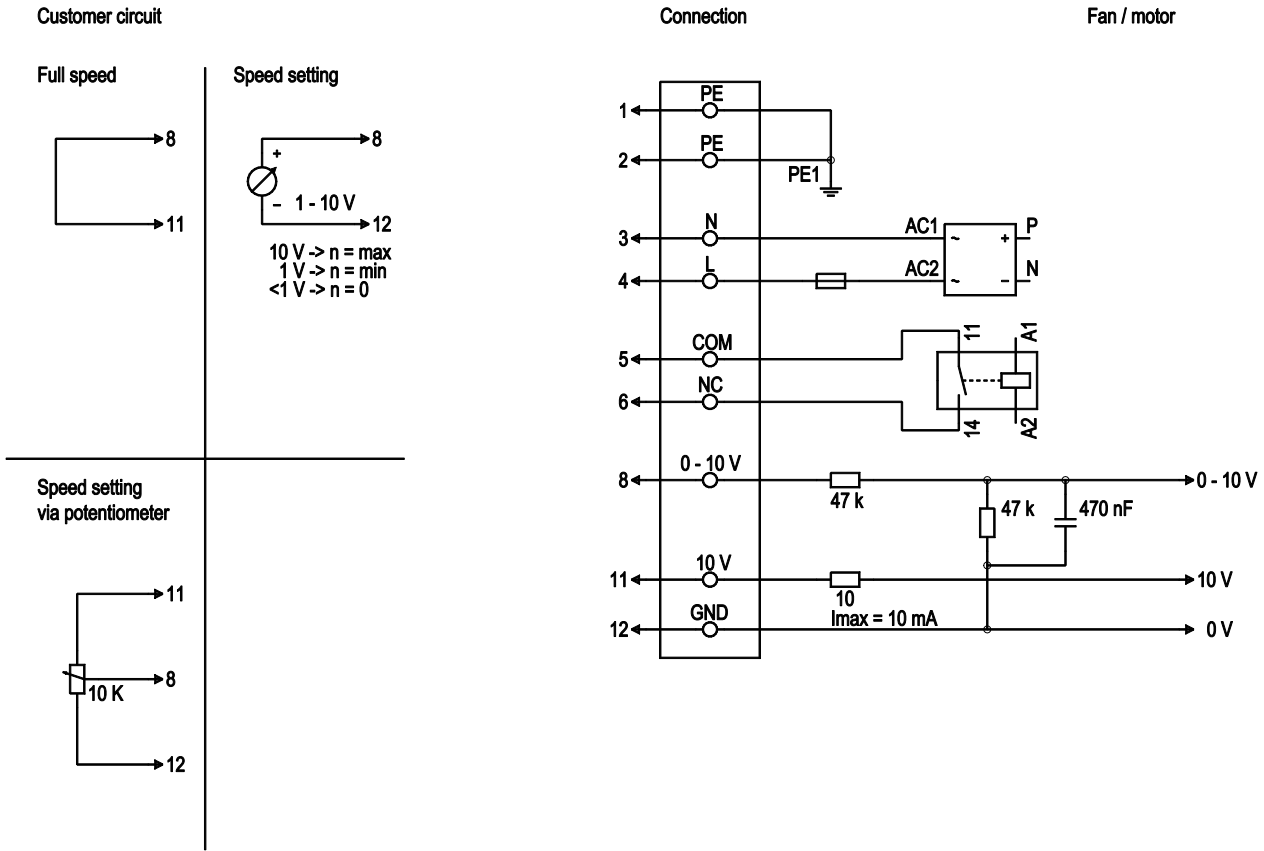

No.	Conn.	Designation	Colour	Function / assignment
1	1,2	PE	green/yellow	Protective earth
1	3	N	blue	Supply voltage, neutral conductor, 50/60 Hz
1	4	L	black	Supply voltage, phase, 50/60 Hz
1	5	COM	white 1	Floating status message contact, normally closed connection (2 A, max. 250 VAC, min. 10 mA)
1	6	NC	white 2	Floating status message contact, normally closed connection
2	8	0 - 10 V	yellow	Control input, set value 0 - 10 VDC, impedance 100 kOhm, SELV
2	11	10 VDC	red	Voltage output 10 VDC (+/-3%), max. 10 mA, supply voltage for ext. devices (e.g. potentiometer), SELV
2	12	GND	blue	Reference mass for control interface, SELV

Charts: Air flow 50 Hz

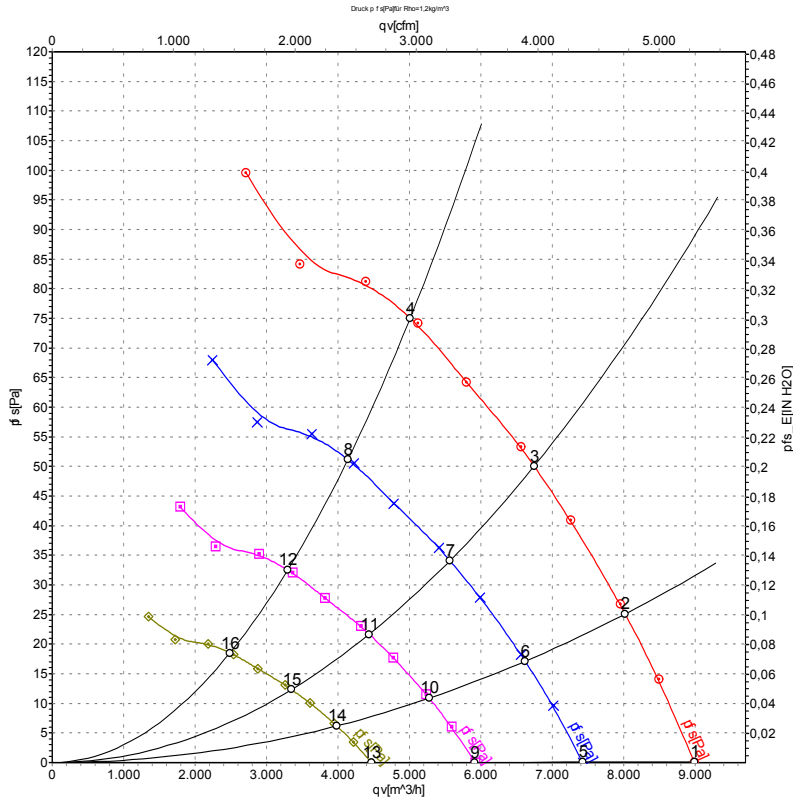

Measurement: LU-126911

Air performance measured as per ISO 5801 Installation category A. For detailed information on the measuring set-up, please contact ebm-papst. Suction-side noise levels: L_{wA} measured as per ISO 13347 / L_{pA} measured with 1m distance to fan axis. The values given are valid under the measuring conditions mentioned above and may vary according to the actual installation situation. With any deviation from the standard set-up, the specific values have to be checked and reviewed with the unit installed.

Measured values

	U	f	n	P _{ed}	I	L _{pA_{in}}	L _{wA_{in}}	L _{wA_{out}}	qv	p _f
	V	Hz	min ⁻¹	W	A	dB(A)	dB(A)	dB(A)	m ³ /h	Pa
1	230	50	800	170	0.76	56	63	62	8985	0
2	230	50	800	211	0.93	57	63	62	8015	25
3	230	50	800	245	1.08	57	63	62	6745	50
4	230	50	800	280	1.20	60	67	67	5010	75
5	230	50	665	96	0.43	52	59	58	7420	0
6	230	50	665	119	0.53	53	59	58	6620	17
7	230	50	665	138	0.61	53	59	58	5565	34
8	230	50	665	155	0.68	56	63	63	4135	51
9	230	50	530	49	0.22	47	54	53	5915	0
10	230	50	530	60	0.27	48	54	53	5275	11
11	230	50	530	70	0.31	48	54	53	4435	22
12	230	50	530	79	0.35	51	58	58	3295	33
13	230	50	400	21	0.09	41	48	47	4465	0
14	230	50	400	26	0.11	42	47	47	3980	6
15	230	50	400	30	0.13	42	48	47	3350	12
16	230	50	400	34	0.15	45	52	52	2485	19

U = Supply voltage · f = Frequency · n = Speed · P_{ed} = Power input · I = Current draw · L_{pA_{in}} = Sound pressure level inlet side · L_{wA_{in}} = Sound power level inlet side · L_{wA_{out}} = Sound power level outlet side
 qv = Air flow · p_f = Pressure increase

