

W3G630-DU31-04 ebmpapst Datasheet

sales@fansco.com

www.fansco.com

Nominal data

Type	W3G630-DU31-04	
Motor	M3G150-IF	
Phase		3~
Nominal voltage	VAC	400
Nominal voltage range	VAC	380 .. 480
Frequency	Hz	50/60
Method of obtaining data		ml
Speed (rpm)	min ⁻¹	1580
Power consumption	W	3700
Current draw	A	5.6
Max. back pressure	Pa	340
Max. back pressure	in. wg	1.36
Min. ambient temperature	°C	-40
Max. ambient temperature	°C	60

ml = Max. load · me = Max. efficiency · fa = Free air · cs = Customer specification · ce = Customer equipment
Subject to change

Data according to Commission Regulation (EU) 327/2011 (prEN 17166)

		Actual	Req. 2015			
01 Overall efficiency η_{es}	%	37.7	36.8	09 Power consumption P_{ed}	kW	3.15
02 Measurement category		A		09 Air flow q_v	m ³ /h	17710
03 Efficiency category		Static		09 Pressure increase p_{fs}	Pa	231
04 Efficiency grade N		40.9	40	10 Speed (rpm) n	min ⁻¹	1580
05 Variable speed drive		Yes		11 Specific ratio*		1.00

Data obtained at optimum efficiency level.

* Specific ratio = $1 + p_s / 100\,000\text{ Pa}$

LU-205533

The efficiency values displayed for achieving conformity with the Ecodesign Regulation EU 327/2011 has been reached with defined air duct components (e.g. inlet rings).
The dimensions must be requested from ebm-papst. If other air conduction geometries are used on the installation side, the ebm-papst evaluation loses its validity/the conformity must be confirmed again.
The product does not fall within the scope of Regulation (EU) 2019/1781 due to the exception specified in Article 2 (2a) (motors completely integrated into a product).

EC axial panel fan - HyBlade

sickle-shaped blades (S series)

Fan housing with guard grille

Technical description

Weight	40.5 kg
Size	630 mm
Motor size	150
Rotor surface	Painted black
Electronics housing material	Die-cast aluminum, painted gray
Blade material	Sheet aluminum insert, sprayed with PP plastic
Fan housing material	Sheet steel, galvanized and coated with black plastic (RAL 9005)
Guard grille material	Steel, coated with black plastic (RAL 9005)
Number of blades	5
Blade pitch	0°
Airflow direction	A
Direction of rotation	Counterclockwise, viewed toward rotor
Degree of protection	IP55
Insulation class	"F"
Moisture (F) / Environmental (H) protection class	H2
Ambient temperature note	Occasional start-up at temperatures between -40°C and -25°C is permitted. For continuous operation at ambient temperatures below -25°C (such as refrigeration applications), use must be made of a fan design with special low-temperature bearings.
Max. permitted ambient temp. for motor (transport/storage)	+80 °C
Min. permitted ambient temp. for motor (transport/storage)	-40 °C
Installation position	Shaft horizontal or rotor on bottom; rotor on top on request
Condensation drainage holes	On rotor side
Mode	S1
Motor bearing	Ball bearing
Technical features	<ul style="list-style-type: none"> - Operation and alarm display with LED - External 15-50 VDC input (parameterization) - Alarm relay - Integrated PI controller - Configurable inputs/outputs (I/O) - MODBUS V6.3 - Motor current limitation - RS-485 MODBUS-RTU - Soft start - Voltage output 3.3-24 VDC, Pmax = 800 mW - Control interface with SELV potential safely disconnected from the mains - Thermal overload protection for electronics/motor - Line undervoltage / phase failure detection
Power Factor Correction (PFC)	Passive (through low-capacitance DC link)
EMC immunity to interference	According to EN 61000-6-2 (industrial environment)
EMC interference emission	According to EN 61000-6-3 (household environment), except EN 61000-3-2 for professionally used equipment with a total rated power greater than 1 kW
Touch current according to IEC 60990 (measuring circuit Fig. 4, TN system)	<= 3.5 mA
Electrical hookup	Terminal box

EC axial panel fan - HyBlade

sickle-shaped blades (S series)

Fan housing with guard grille

Protection class assignment	I; If a protective earth is connected. The built-in component has several local protection class assignments. The final protection class is determined by the intended installation.
Conformity with standards	EN 61800-5-1; CE
Approval	UL 1004-7 + 60730-1; EAC; CSA C22.2 No. 77 + CAN/CSA-E60730-1

EC axial panel fan - HyBlade

sickle-shaped blades (S series)

Fan housing with guard grille

Product drawing

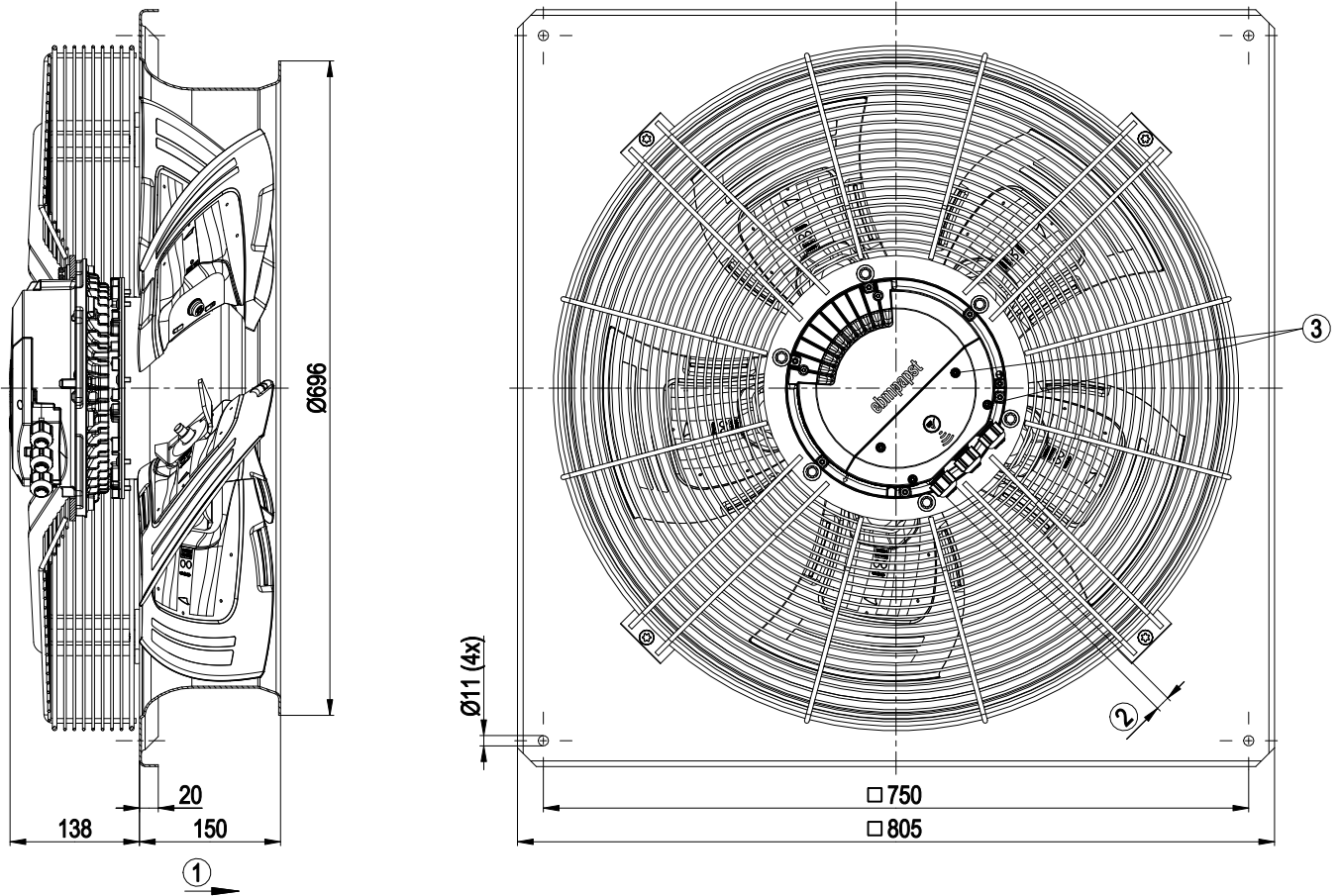

1	Direction of air flow "A"
2	Cable diameter min. 4 mm, max. 10 mm, tightening torque 4 ± 0.6 Nm (The tightening torque is designed for PVC cables. If the cable materials are different, the tightening torque may have to be adjusted)
3	Tightening torque 1.5 ± 0.2 Nm

EC axial panel fan - HyBlade

sickle-shaped blades (S series)

Fan housing with guard grille

Connection diagram

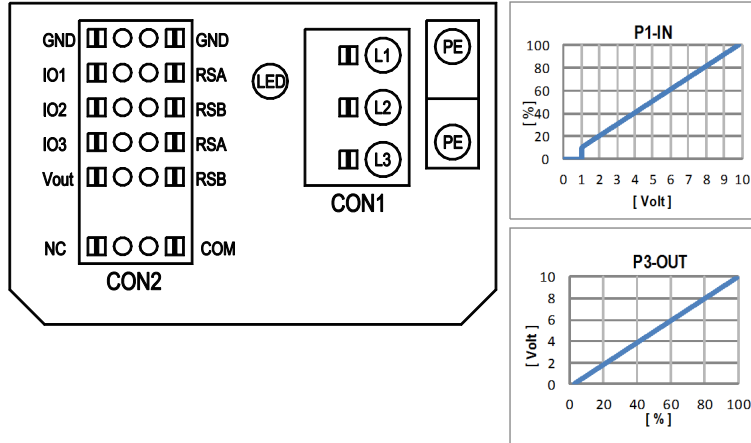

No.	Conn.	Designation	Function/assignment
	CON1	L1, L2, L3	Power supply, phase, see nameplate for voltage range
	PE	PE	Protective earth
	CON2	RSA	RS485 interface for MODBUS, RSA; SELV
	CON2	RSB	RS485 interface for MODBUS, RSB; SELV
	CON2	GND	Reference ground for control interface, SELV
	CON2	IO1	Function parameterizable (see "Optional interface functions" table) Factory setting: Digital input - high active, function: Disable input, SELV - inactive: Pin open or applied voltage < 1.5 VDC - active: applied voltage 3.5-50 VDC Reset function: Triggering of error reset on change of state from "enabled" to "disabled"
	CON2	IO2	Function parameterizable (see "Optional interface functions" table) Factory setting: Analog input 0-10 V / PWM, Ri=100 kΩ, function: Set value Characteristic curve parameterizable (see input characteristic curve P1-IN), SELV
	CON2	IO3	Function parameterizable (see "Optional interface functions" table) Factory setting: Analog output 0-10 V, max. 5 mA, function: Fan modulation level Characteristic curve parameterizable (see output characteristic curve P3-OUT), SELV
	CON2	Vout	Voltage output 3.3-24 VDC ±5%, Pmax=800 mW, voltage parameterizable Factory setting: 10 VDC short-circuit-proof, supply for external devices, SELV alternatively: 15-50 VDC input for parameterization via MODBUS without line voltage
	CON2	COM	Status relay, floating status contact, common connection, contact rating 250 VAC / 2 A (AC1) / min. 10 mA, reinforced insulation on supply side and on control interface side
	CON2	NC	Status relay, floating status contact, break for failure
		LED	green: status = good, ready for operation orange: status = warning red: status = failure
		P1-IN	Input characteristic curve
		P3-OUT	Output characteristic curve

EC axial panel fan - HyBlade

sickle-shaped blades (S series)

Fan housing with guard grille

Terminal/plug assignment

CON2	configurable IO mode	electrical specification	configurable IO functions: normal / inverse	INPUT		OUTPUT												
				source: set value	source: sensor value	switch: parameter set: #1 / #2	switch: control function: heating (pos.) / cooling (neg.)	switch: direction of rotation: cw / ccw	switch: set value source	switch: fan enable / disable	signal: tach out	signal: diagnostics out	signal: fan modulation level %	signal: actual speed	signal: system modulation level %	signal: remote control output 0-10V	pulse input for auto-addressing	pulse output for auto-addressing
IO1	○ Din1 (active high): digital input	active: applied voltage 3.5-50VDC, SELV not active: pin open or applied voltage < 1.5VDC	D158 [0]	○	○	○	○	○	○	○	○	○	○	○	○	○	○	○
	○ Ain1 0-10V/PWM: analog input	RI = 100k, characteristic curve parameterizable, f _{PWM} = 1k..10kHz, SELV	D158 [2]	○	○	○	○	○	○	○	○	○	○	○	○	○	○	○
	○ Tach out (open collector output)	U _{max} = 50VDC, I _{max} = 20mA, SELV	D158 [5]	○	○	○	○	○	○	○	○	○	○	○	○	○	○	○
	○ Diagnostics out (open collector output)	U _{max} = 50VDC, I _{max} = 20mA, SELV	D158 [6]	○	○	○	○	○	○	○	○	○	○	○	○	○	○	○
	○ Din2 (active high): digital input	active: applied voltage 3.5-50VDC, SELV not active: pin open or applied voltage < 1.5VDC	D159 [0]	○	○	○	○	○	○	○	○	○	○	○	○	○	○	○
	○ Ain2 0-10V/PWM: analog input	RI = 100k, characteristic curve parameterizable, f _{PWM} = 1k..10kHz, SELV	D159 [2]	○	○	○	○	○	○	○	○	○	○	○	○	○	○	○
IO2	○ Ain2 4-20mA: analog input	RI = 125R, characteristic curve parameterizable, SELV	D159 [3]	○	○	○	○	○	○	○	○	○	○	○	○	○	○	○
	○ Din3 (active high): digital input	active: applied voltage 3.5-50VDC, SELV not active: pin open or applied voltage < 1.5VDC	D15A [0]	○	○	○	○	○	○	○	○	○	○	○	○	○	○	○
	○ Din3 (active low): digital input	active: applied voltage < 1.5VDC, SELV not active: pin open or applied voltage 3.5-50VDC	D15A [1]	○	○	○	○	○	○	○	○	○	○	○	○	○	○	○
IO3	○ PWMIn3: digital input, idle level high	PWM = 40Hz - 10kHz, characteristics parameterizable	D15A [7]	○	○	○	○	○	○	○	○	○	○	○	○	○	○	○
	○ PWMIn3: digital input, idle level low	active: pin open or applied voltage 3.5-50VDC not active: applied voltage < 1.5VDC, SELV	D15A [8]	○	○	○	○	○	○	○	○	○	○	○	○	○	○	○
	○ Aout3 0-10V: analog output	function parameterizable, max. 5mA max output frequency 300Hz, SELV	D15A [4]	○	○	○	○	○	○	○	○	○	○	○	○	○	○	○
RSA	○ Tacho out (pulses), analog output	0-10V max. 5mA max output frequency 300Hz, SELV	D15A [5]	○	○	○	○	○	○	○	○	○	○	○	○	○	○	○
	○ Diagnostics out (pulses)	0-10V max. 5mA max output frequency 300Hz, SELV	D15A [6]	○	○	○	○	○	○	○	○	○	○	○	○	○	○	○
RSB	RS485 bus connection,	active: applied voltage 3.5-50VDC not active: pin open or applied voltage < 1.5VDC, SELV	MODBUS RTU, specification V6.3, SELV	○	○	○	○	○	○	○	○	○	○	○	○	○	○	○
Vout	voltage output	voltage parameterizable 3.3...24VDC +/- 5%, P _{max} =800mW, short-circuit-proof, supply for external devices, SELV	D16E [...]	○	○	○	○	○	○	○	○	○	○	○	○	○	○	○
	alternatively: Input auxiliary power supply/for parameterization via RS485/MODBUS RTU without line voltage	15...50VDC		○	○	○	○	○	○	○	○	○	○	○	○	○	○	○

○ configurable option

For further information and additional functions see EC Control Software: Fan-Set-App. or MODBUS Parameter Specification V6.3

EC axial panel fan - HyBlade

sickle-shaped blades (S series)

Fan housing with guard grille

Curves: Air performance 50 Hz

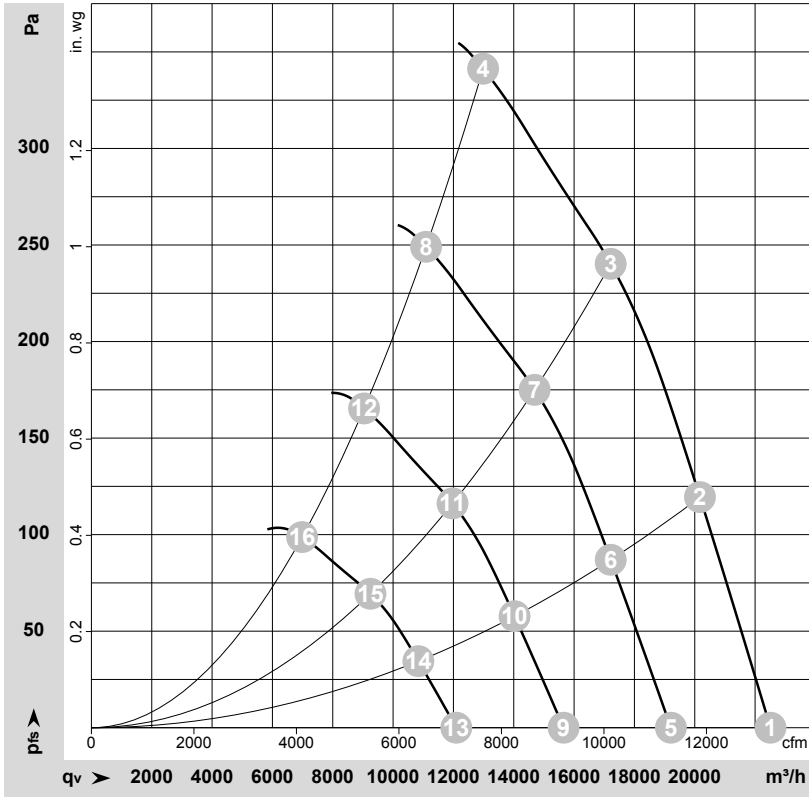

$\rho = 1.15 \text{ kg/m}^3 \pm 2 \%$

Measurement: LU-205533-1
Date: 2020-03-12
Housing: 38633-2-4037

Air performance measured according to ISO 5801 installation category A. For detailed information on the measurement setup, contact ebm-papst. Intake sound level: Sound power level according to ISO 13347 / sound pressure level measured at 1 m distance from fan axis. The values given are valid under the specified measuring conditions and may vary due to conditions of installation. For deviations from the standard configuration, the parameters have to be checked on the installed unit.

Measured values

	Wired	U	f	n	P _{ed}	I	q _v	P _{fs}	q _v	P _{fs}
		V	Hz	min ⁻¹	W	A	m ³ /h	Pa	cfm	in. wg
1	3~	400	50	1580	2604	4.02	22510	0	13250	0.00
2	3~	400	50	1580	2879	4.43	20170	120	11875	0.48
3	3~	400	50	1580	3210	4.92	17215	240	10130	0.96
4	3~	400	50	1580	3700	5.60	12985	340	7645	1.36
5	3~	400	50	1350	1618	2.50	19210	0	11305	0.00
6	3~	400	50	1350	1789	2.75	17215	89	10130	0.36
7	3~	400	50	1350	1996	3.06	14690	176	8645	0.71
8	3~	400	50	1350	2346	3.58	11090	249	6530	1.00
9	3~	400	50	1100	875	1.35	15650	0	9210	0.00
10	3~	400	50	1100	968	1.49	14025	59	8255	0.24
11	3~	400	50	1100	1080	1.66	11970	117	7045	0.47
12	3~	400	50	1100	1269	1.94	9040	166	5320	0.67
13	3~	400	50	850	404	0.62	12095	0	7120	0.00
14	3~	400	50	850	447	0.69	10840	35	6380	0.14
15	3~	400	50	850	498	0.76	9250	70	5445	0.28
16	3~	400	50	850	586	0.89	6985	99	4110	0.40

Wired = Wiring · U = Voltage · f = Frequency · n = Speed (rpm) · P_{ed} = Power consumption · I = Current draw · q_v = Air flow · p_{fs} = Pressure increase