

# EC axial fan - HyBlade

sickle-shaped blades (S series)  
with square full nozzle, for barn ventilation

W3G630-DU23-35 ebmpapst Datasheet  
sales@fansco.com  
www.fansco.com

Limited partnership · Headquarters Mulfingen  
Amtsgericht (court of registration) Stuttgart · HRA 590344  
General partner Elektrobau Mulfingen GmbH · Headquarters Mulfingen  
Amtsgericht (court of registration) Stuttgart · HRB 590142

## Nominal data

Type	W3G630-DU23-35	
Motor	M3G150-IF	
Phase		3~
Nominal voltage	VAC	400
Nominal voltage range	VAC	380 .. 480
Frequency	Hz	50/60
Method of obtaining data		ml
Speed (rpm)	min <sup>-1</sup>	1510
Power consumption	W	3200
Current draw	A	5.0
Max. back pressure	Pa	290
Max. back pressure	in. wg	1.16
Min. ambient temperature	°C	-25
Max. ambient temperature	°C	65

ml = Max. load · me = Max. efficiency · fa = Free air · cs = Customer specification · ce = Customer equipment  
Subject to change

## Data according to Commission Regulation (EU) 327/2011

		Actual	Req. 2015		
01 Overall efficiency $\eta_{es}$	%	36.9	36.9	09 Power consumption $P_{ed}$	kW
02 Measurement category		A		09 Air flow $q_v$	m <sup>3</sup> /h
03 Efficiency category		Static		09 Pressure increase $p_{fs}$	Pa
04 Efficiency grade N		40	40	10 Speed (rpm) n	min <sup>-1</sup>
05 Variable speed drive		Yes		11 Specific ratio*	
					1.00

Data obtained at optimum efficiency level.  
The ErP data is determined using a motor-impeller combination in a standardized measurement setup.

\* Specific ratio =  $1 + p_s / 100\,000\text{ Pa}$

LU-114811



# EC axial fan - HyBlade

sickle-shaped blades (S series)  
with square full nozzle, for barn ventilation

## Technical description

<b>Weight</b>	41.8 kg
<b>Size</b>	630 mm
<b>Motor size</b>	150
<b>Rotor surface</b>	Painted black
<b>Electronics housing material</b>	Die-cast aluminum, painted black
<b>Blade material</b>	Sheet aluminum insert (painted black), sprayed with PP plastic
<b>Support ring material</b>	Steel, galvanized and coated with black plastic (RAL 9005)
<b>Fan housing material</b>	Sheet steel, galvanized and coated with black plastic (RAL 9005)
<b>Number of blades</b>	5
<b>Blade pitch</b>	0°
<b>Airflow direction</b>	A
<b>Direction of rotation</b>	Counterclockwise, viewed toward rotor
<b>Degree of protection</b>	IP55
<b>Insulation class</b>	"F"
<b>Moisture (F) / Environmental (H) protection class</b>	F5
<b>Max. permitted ambient temp. for motor (transport/storage)</b>	+ 80 °C
<b>Min. permitted ambient temp. for motor (transport/storage)</b>	- 40 °C
<b>Installation position</b>	Shaft horizontal or rotor on top; rotor on bottom on request
<b>Condensation drainage holes</b>	On stator side
<b>Mode</b>	S1
<b>Motor mounting</b>	Ball bearing
<b>Technical features</b>	<ul style="list-style-type: none"> <li>- Output 10 VDC, max. 10 mA</li> <li>- Output 20 VDC, max. 50 mA</li> <li>- Output for slave 0-10 V</li> <li>- Input for sensor 0-10 V or 4-20 mA</li> <li>- External 24 V input (parameter setting)</li> <li>- External release input</li> <li>- Alarm relay</li> <li>- Integrated PID controller</li> <li>- Power limiter</li> <li>- Motor current limitation</li> <li>- PFC, passive</li> <li>- RS-485 MODBUS-RTU</li> <li>- Soft start</li> <li>- EEPROM write cycles: 100,000 maximum</li> <li>- Control input 0-10 VDC / PWM</li> <li>- Control interface with SELV potential safely disconnected from the mains</li> <li>- Thermal overload protection for electronics/motor</li> <li>- Line undervoltage / phase failure detection</li> </ul>
<b>Touch current according to IEC 60990 (measuring circuit Fig. 4, TN system)</b>	<= 3.5 mA
<b>Electrical hookup</b>	Terminal box
<b>Motor protection</b>	Reverse polarity and locked-rotor protection
<b>Protection class</b>	I (with customer connection of protective earth)
<b>Conformity with standards</b>	EN 61800-5-1; CE



W3G630-DU23-35

# EC axial fan - HyBlade

sickle-shaped blades (S series)

with square full nozzle, for barn ventilation

Approval

EAC; UL 1004-7 + 60730; CSA C22.2 No. 77 + CAN/CSA-E60730-1



# EC axial fan - HyBlade

sickle-shaped blades (S series)  
with square full nozzle, for barn ventilation

## Product drawing

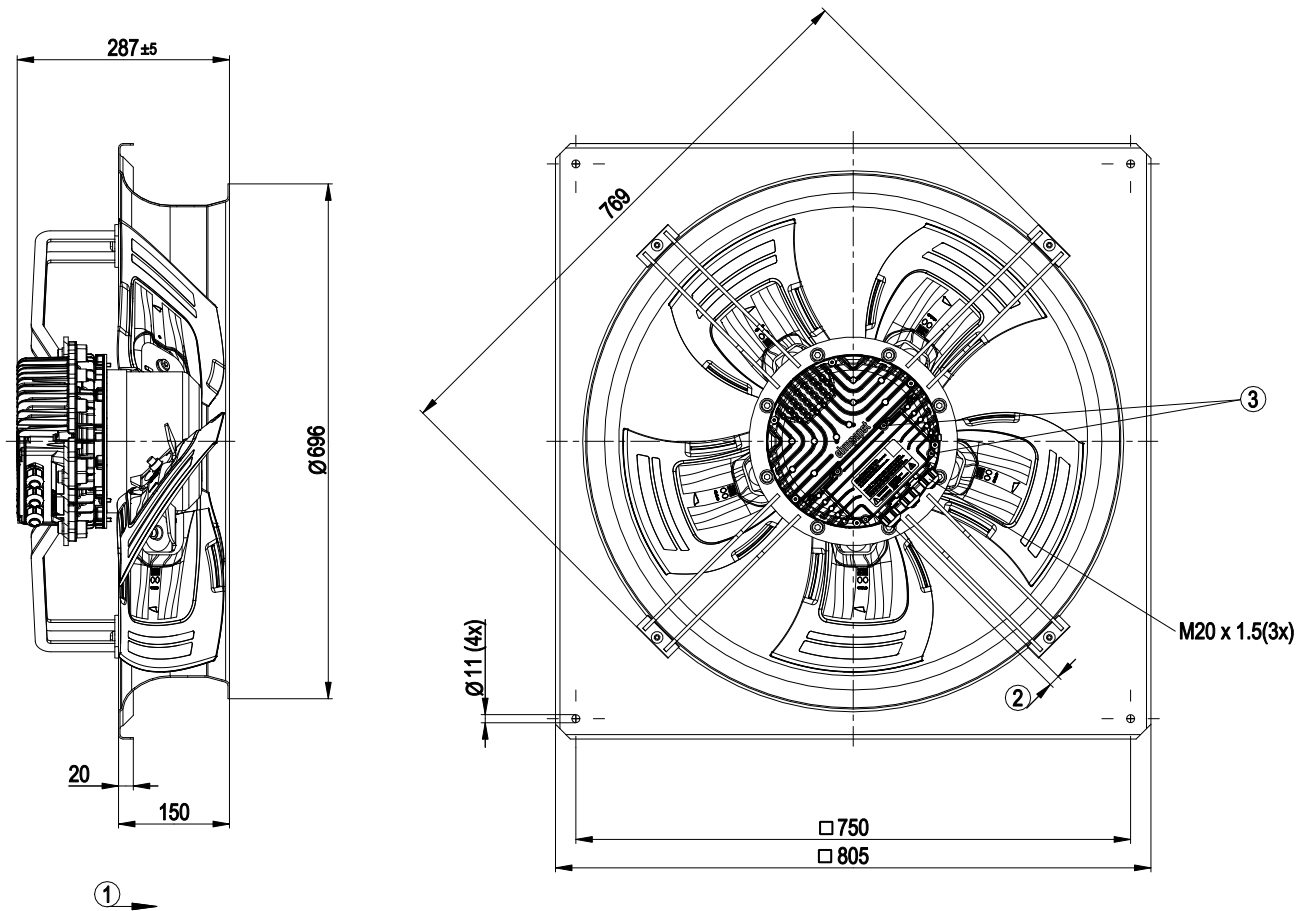

1	Direction of air flow "A"
2	Cable diameter min. 4 mm, max. 10 mm, tightening torque $4 \pm 0.6$ Nm
3	Tightening torque $3.5 \pm 0.5$ Nm

# EC axial fan - HyBlade

sickle-shaped blades (S series)  
with square full nozzle, for barn ventilation

## Connection diagram

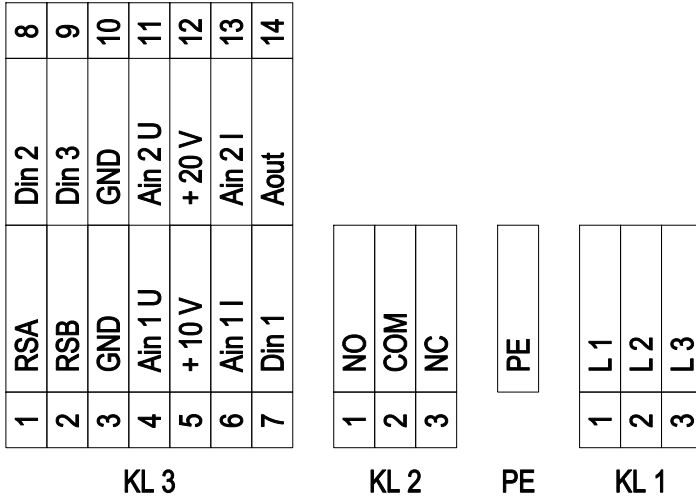

No.	Conn.	Designation	Function/assignment
KL 1	1	L1	Supply connection, power supply 3-phase 380-480 VAC, 50/60 Hz
KL 1	2	L2	Supply connection, power supply 3-phase 380-480 VAC, 50/60 Hz
KL 1	3	L3	Supply connection, power supply 3-phase 380-480 VAC, 50/60 Hz
PE		PE	Ground connection, PE connection
KL 2	1	NO	Status relay, floating status contact; make for failure
KL2	2	COM	Status relay, floating status contact; changeover contact; common connection; contact rating 250 VAC / max. 2 A (AC1) / min. 10 mA
KL2	3	NC	Status relay, floating status contact; break for failure
KL 3	1	RSA	Bus connection RS485, RSA, MODBUS-RTU; SELV
KL 3	2	RSB	Bus connection RS485, RSB, MODBUS-RTU; SELV
KL 3	3 / 10	GND	Reference ground for control interface; SELV
KL 3	4	Ain1 U	Analog input 1, set value: 0-10 V, Ri = 100 kΩ, adjustable curve, only usable as alternative to input Ain1 I; SELV
KL 3	5	+ 10 V	Fixed voltage output 10 VDC, +10 V ±3%, max. 10 mA, short-circuit-proof power supply for external devices (e.g. pot); SELV
KL 3	6	Ain1 I	Analog input 1, set value: 4-20 mA, Ri = 100 Ω, adjustable curve, only usable as alternative to input Ain1U; SELV
KL 3	7	Din1	Digital input 1: enable electronics, enable: pin open or applied voltage 5-50 VDC disable: bridge to GND or applied voltage < 1 VDC reset function: triggers software reset after a level change to < 1 VDC; SELV
KL 3	8	Din2	Digital input 2: Switching parameter sets 1/2, according to EEPROM setting, the valid or used parameter set can be selected via bus or via digital input DIN2. Parameter set 1: pin open or applied voltage 5-50 VDC Parameter set 2: bridge to GND or applied voltage < 1 VDC; SELV
KL 3	9	Din3	Digital input 3: according to EEPROM setting, the integrated controller's direction of action can be selected as normal/inverse via bus or digital input normal: pin open or applied voltage 5-50 VDC inverse: bridge to GND or applied voltage < 1 VDC; SELV
KL 3	11	Ain2 U	Analog input 2, measured value: 0-10 V, Ri = 100 kΩ, adjustable curve, only usable as alternative to input Ain2I; SELV
KL 3	12	+ 20 V	Fixed voltage output 20 VDC, +20 V ±5/-10%, max. 50 mA, short-circuit-proof power supply for external devices (e.g. sensors); SELV



# EC axial fan - HyBlade

sickle-shaped blades (S series)

with square full nozzle, for barn ventilation

No.	Conn.	Designation	Function/assignment
KL 3	13	Ain2 I	Analog input 2, measured value: 4-20 mA, $R_i = 100 \Omega$ , adjustable curve, only usable as alternative to input Ain2U; SELV
KL 3	14	Aout	Analog output 0-10 VDC, max. 5 mA, output of current motor modulation level / motor speed adjustable curve; SELV



# EC axial fan - HyBlade

sickle-shaped blades (S series)  
with square full nozzle, for barn ventilation

## Curves: Air performance 50 Hz

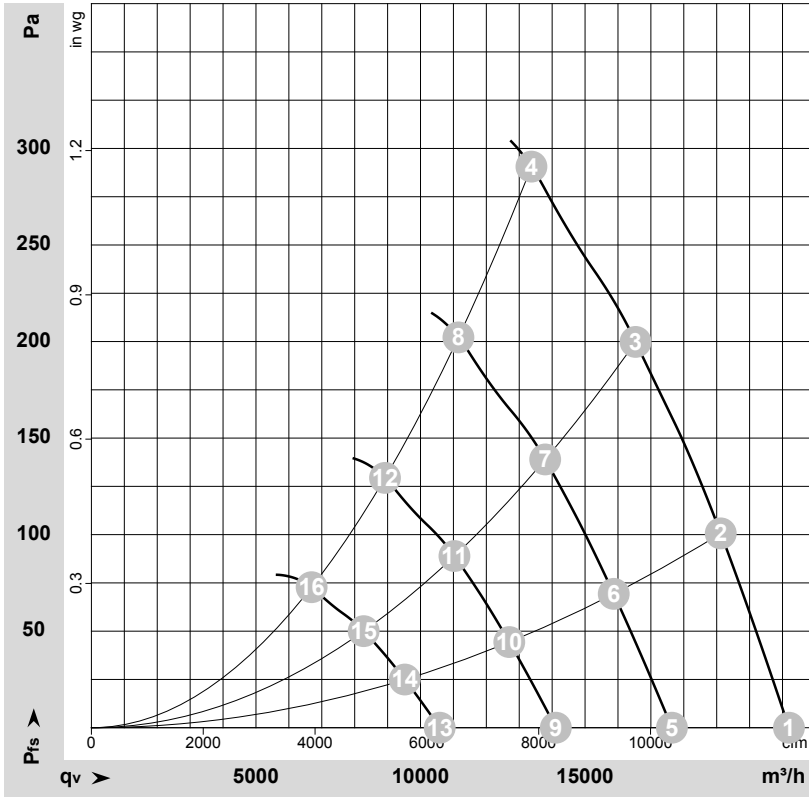

$\rho = 1.15 \text{ kg/m}^3 \pm 2 \%$

Measurement: LU-114811-1

Air performance measured according to ISO 5801 installation category A. For detailed information on the measurement setup, contact ebmpapst. Intake sound level: Sound power level according to ISO 13347 / sound pressure level measured at 1 m distance from fan axis. The values given are valid under the specified measuring conditions and may vary due to conditions of installation. For deviations from the standard configuration, the parameters have to be checked on the installed unit.

## Measured values

	Wired	U	f	n	P <sub>ed</sub>	I	LpA <sub>in</sub>	LwA <sub>in</sub>	LwA <sub>out</sub>	q <sub>v</sub>	P <sub>fs</sub>	q <sub>v</sub>	P <sub>fs</sub>
		V	Hz	min <sup>-1</sup>	W	A	dB(A)	dB(A)	dB(A)	m <sup>3</sup> /h	Pa	cfm	in. wg
1	Y	400	50	1510	2484	3.77	74	81	83	21195	0	12475	0.00
2	Y	400	50	1510	2757	4.20	74	81	82	19125	100	11255	0.40
3	Y	400	50	1510	2979	4.52	74	81	82	16535	200	9730	0.80
4	Y	400	50	1510	3200	5.00	79	86	85	13370	290	7870	1.16
5	Y	400	50	1250	1432	2.17	69	77	78	17640	0	10385	0.00
6	Y	400	50	1250	1576	2.40	69	76	78	15870	69	9340	0.28
7	Y	400	50	1250	1727	2.62	70	77	77	13790	139	8115	0.56
8	Y	400	50	1250	1857	2.83	74	81	80	11150	203	6565	0.81
9	Y	400	50	1000	733	1.11	63	71	72	14110	0	8305	0.00
10	Y	400	50	1000	807	1.23	63	71	72	12695	44	7475	0.18
11	Y	400	50	1000	884	1.34	64	71	72	11030	89	6495	0.36
12	Y	400	50	1000	951	1.45	68	76	75	8920	130	5250	0.52
13	Y	400	50	750	309	0.47	56	64	65	10585	0	6230	0.00
14	Y	400	50	750	340	0.52	56	63	65	9525	25	5605	0.10
15	Y	400	50	750	373	0.57	57	64	64	8275	50	4870	0.20
16	Y	400	50	750	401	0.61	61	68	67	6690	73	3940	0.29

Wired = Wiring · U = Power supply · f = Frequency · n = Speed (rpm) · P<sub>ed</sub> = Power consumption · I = Current draw · LpA<sub>in</sub> = Sound pressure level intake side · LwA<sub>in</sub> = Sound power level intake side  
LwA<sub>out</sub> = Sound power level outlet side · q<sub>v</sub> = Air flow · P<sub>fs</sub> = Pressure increase

