

W3G630-DD02-55 ebmpapst Datasheet

sales@fansco.com

www.fansco.com

## Nominal data

Type	W3G630-DD02-55	
Motor	M3G084-GF	
Phase		1~
Nominal voltage	VAC	230
Frequency	Hz	50/60
Type of data definition		ml
Speed	min <sup>-1</sup>	750
Power input	W	250
Current draw	A	1.6
Min. ambient temperature	°C	-25
Max. ambient temperature	°C	40

ml = max. load · me = max. efficiency · fa = running at free air · cs = customer specs · cu = customer unit  
Subject to alterations

## Data according to ErP directive

Installation category	A
Efficiency category	Static
Variable speed drive	Yes
Specific ratio*	1.00

\* Specific ratio =  $1 + p_{fs} / 100\,000\text{ Pa}$

		Actual	Request 2013	Request 2015
Overall efficiency $\eta_{es}$		45.5	25.1	29.1
Efficiency grade N		56.4	36	40
Power input $P_{ed}$	kW	0.19		
Air flow $q_v$	m <sup>3</sup> /h	6220		
Pressure increase $p_{fs}$	Pa	46		
Speed n	min <sup>-1</sup>	755		

Data established at point of optimum efficiency



## Technical features

Mass	22.5 kg
Size	630 mm
Surface of rotor	Coated in black
Material of electronics housing	Die-cast aluminium
Material of blades	Press-fitted sheet steel blank, sprayed with PP plastic
Material of wall ring	Sheet steel, pre-galvanised and coated in black plastic
Material of guard grille	Steel, phosphated and coated in black plastic
Number of blades	5
Direction of air flow	"A"
Direction of rotation	Clockwise, seen on rotor
Type of protection	IP 54
Insulation class	"B"
Humidity class	F4-1
Max. permissible ambient motor temp. (transp./ storage)	80 °C
Min. permissible ambient motor temp. (transp./storage)	-40 °C
Mounting position	Shaft horizontal or rotor on bottom; rotor on top on request
Condensate discharge holes	Rotor-side
Operation mode	S1
Motor bearing	Ball bearing
Technical features	<ul style="list-style-type: none"> <li>- Control input 0-10 VDC / PWM</li> <li>- Output 10 VDC, max. 1.1 mA</li> <li>- Over-temperature protected electronics / motor</li> <li>- Alarm relay</li> <li>- Line undervoltage detection</li> <li>- Motor current limit</li> <li>- Soft start</li> </ul>
EMC interference immunity	Acc. to EN 61000-6-2 (industrial environment)
EMC harmonics	Acc. to EN 61000-3-2/3
EMC interference emission	Acc. to EN 61000-6-3 (household environment)
Touch current acc. IEC 60990 (measuring network Fig. 4, TN system)	<= 3.5 mA
Motor protection	Thermal overload protector (TOP) wired internally
Cable exit	Variable
Protection class	I (if protective earth is connected by customer)
Product conforming to standard	CE

# EC axial fan - HyBlade®

sickled blades (S series)

with full square nozzle

## Product drawing

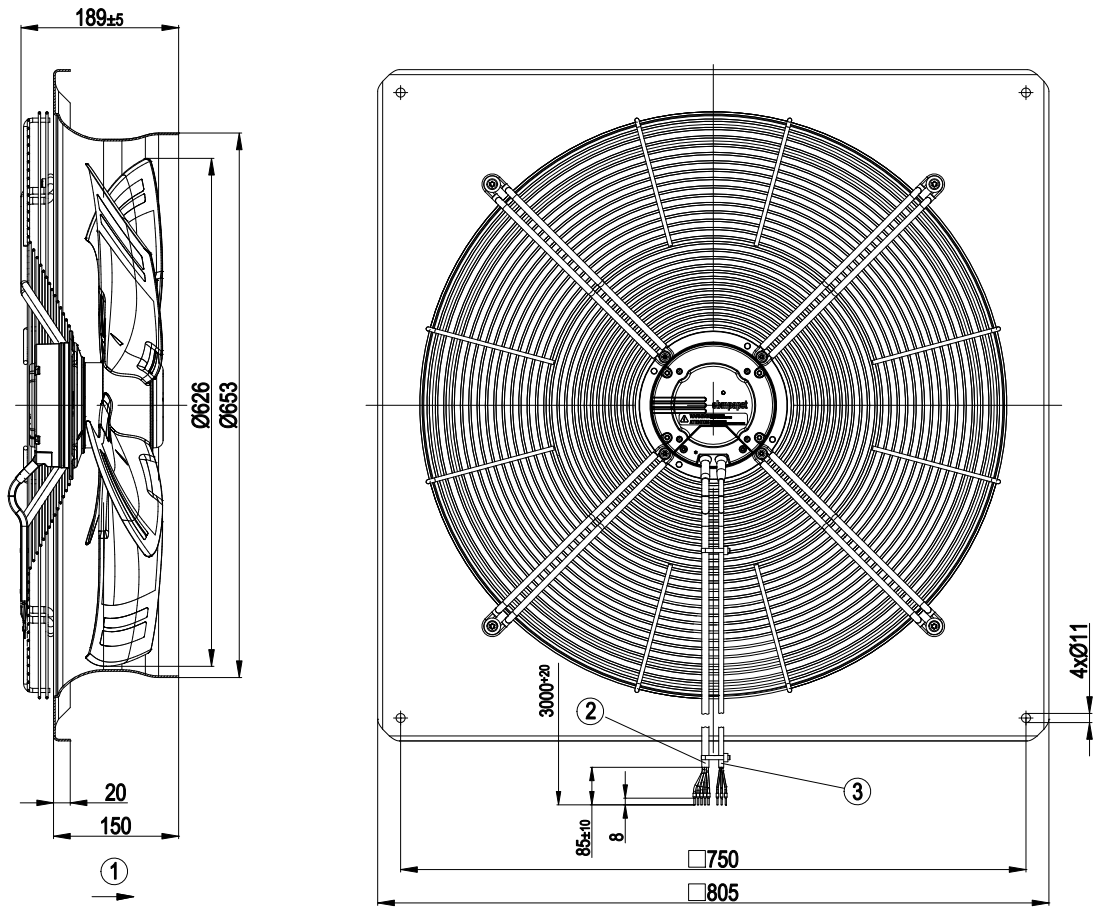

- |   |   |
|---|---|
| 1 | Direction of air flow "A"                               |
| 2 | Connection line AWG18, 5 x crimped core-end sleeves     |
| 3 | Anschlussleitung AWG22, 3 x Aderendhülsen angeschlossen |



# EC axial fan - HyBlade®

sickled blades (S series)  
with full square nozzle

## Connection screen

### Customer circuit

Notes on various control possibilities and their applications

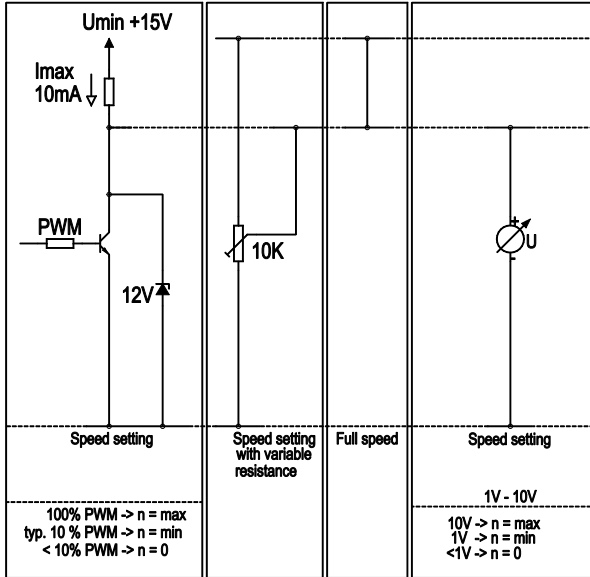

### Connection

### Fan / motor

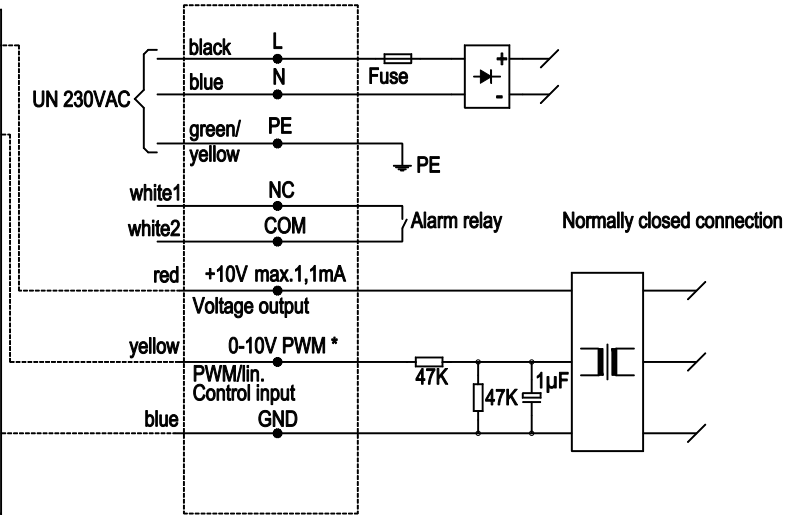

## Charts: Air flow 50 Hz

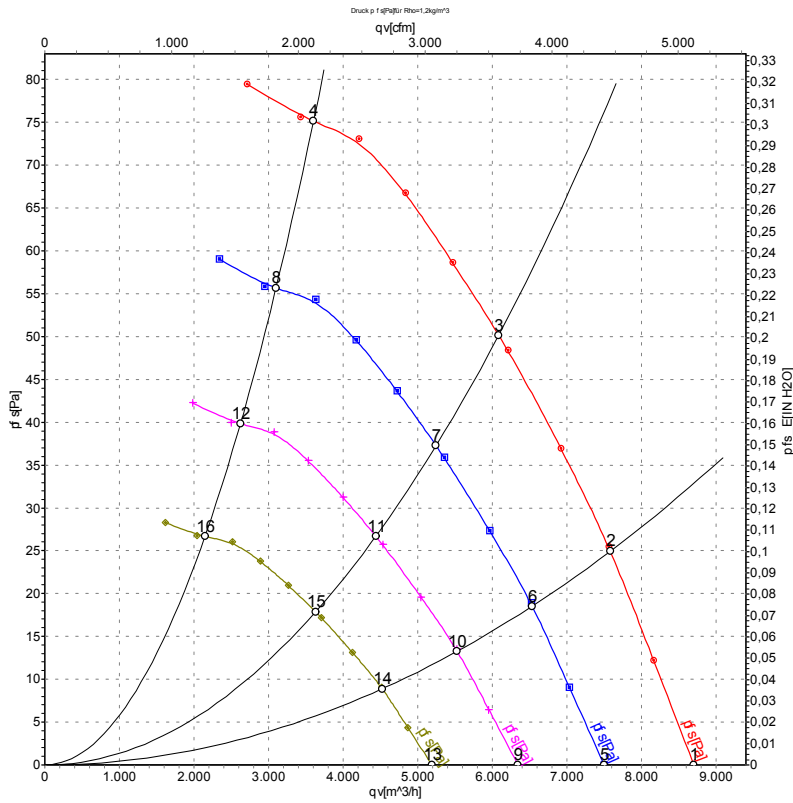

Measurement: LU-119952

Air performance measured as per ISO 5801 Installation category A. For detailed information on the measuring set-up, please contact ebm-papst. Suction-side noise levels: LwA measured as per ISO 13347 / LpA measured with 1m distance to fan axis. The values given are valid under the measuring conditions mentioned above and may vary according to the actual installation situation. With any deviation from the standard set-up, the specific values have to be checked and reviewed with the unit installed.

## Measured values

	U	f	n	P <sub>ed</sub>	I	LpA <sub>in</sub>	LwA <sub>in</sub>	LwA <sub>out</sub>	qv	p <sub>fs</sub>
	V	Hz	min <sup>-1</sup>	W	A	dB(A)	dB(A)	dB(A)	m <sup>3</sup> /h	Pa
1	230	50	750	139	0.90	55	62	62	8700	0
2	230	50	750	177	1.12	56	62	62	7580	25
3	230	50	750	201	1.26	56	63	62	6085	50
4	230	50	750	250	1.60	64	71	71	3600	75
5	230	50	650	89	0.58	52	59	59	7500	0
6	230	50	650	113	0.72	53	59	59	6535	19
7	230	50	650	129	0.81	53	59	59	5245	37
8	230	50	650	149	0.93	60	68	68	3100	56
9	230	50	550	54	0.35	49	55	55	6345	0
10	230	50	550	69	0.44	49	55	55	5530	14
11	230	50	550	78	0.49	49	56	56	4440	27
12	230	50	550	90	0.56	57	65	65	2625	40
13	230	50	450	30	0.19	44	51	51	5190	0
14	230	50	450	38	0.24	45	51	51	4525	9
15	230	50	450	43	0.27	45	51	51	3630	18
16	230	50	450	49	0.31	52	60	60	2145	27

U = Supply voltage · f = Frequency · n = Speed · P<sub>ed</sub> = Power input · I = Current draw · LpA<sub>in</sub> = Sound pressure level inlet side · LwA<sub>in</sub> = Sound power level inlet side · LwA<sub>out</sub> = Sound power level outlet side  
 qv = Air flow · p<sub>fs</sub> = Pressure increase

