

# EC axial fan - HyBlade®

sickled blades (S series)

with full square nozzle



W3G500-GN33-01 ebmpapst Datasheet

sales@fansco.com

www.fansco.com

Limited partnership · Headquarters Muldingen  
County court Stuttgart · HRA 590344

General partner Elektrobau Muldingen GmbH · Headquarters Muldingen  
County court Stuttgart · HRB 590142



## Nominal data

Type	W3G500-GN33-01	
Motor	M3G112-GA	
Phase		3~
Nominal voltage	VAC	400
Nominal voltage range	VAC	380 .. 480
Frequency	Hz	50/60
Type of data definition		ml
Speed	min <sup>-1</sup>	1600
Power input	W	980
Current draw	A	1.6
Min. ambient temperature	°C	-25
Max. ambient temperature	°C	+60

ml = Max. load · me = Max. efficiency · fa = Running at free air · cs = Customer specs · cu = Customer unit  
Subject to alterations

## Data according to ErP directive

Installation category	A
Efficiency category	Static
Variable speed drive	Yes
Specific ratio*	1.00

\* Specific ratio =  $1 + p_{fs} / 100\,000\text{ Pa}$

		Actual	Request 2013	Request 2015
Overall efficiency $\eta_{es}$		43.5	29.7	33.7
Efficiency grade N		49.8	36	40
Power input $P_{ed}$	kW	1		
Air flow $q_v$	m <sup>3</sup> /h	6630		
Pressure increase $p_{fs}$	Pa	218		
Speed n	min <sup>-1</sup>	1610		

Data definition with optimum efficiency.



## Technical features

Mass	16.5 kg
Size	500 mm
Surface of rotor	Coated in black
Material of electronics housing	Die-cast aluminium, coated in black
Material of blades	Press-fitted sheet steel blank, sprayed with PP plastic
Material of wall ring	Sheet steel, pre-galvanised and coated in black plastic (RAL 9005)
Material of guard grille	Steel, coated in black plastic (RAL9005)
Number of blades	5
Direction of air flow	"V"
Direction of rotation	Counter-clockwise, seen on rotor
Type of protection	IP 54
Insulation class	"B"
Humidity class	F4-1
Max. permissible ambient motor temp. (transp./ storage)	+ 80 °C
Min. permissible ambient motor temp. (transp./storage)	- 40 °C
Mounting position	Shaft horizontal or rotor on bottom; rotor on top on request
Condensate discharge holes	Rotor-side
Operation mode	S1
Motor bearing	Ball bearing
Technical features	<ul style="list-style-type: none"> <li>- Output 10 VDC, max. 1.1 mA</li> <li>- Alarm relay</li> <li>- Integrated PID controller</li> <li>- Motor current limit</li> <li>- PFC, passive</li> <li>- Soft start</li> <li>- Control input 0-10 VDC / PWM</li> <li>- Control interface with SELV potential safely disconnected from the mains</li> <li>- Over-temperature protected electronics / motor</li> <li>- Line undervoltage / phase failure detection</li> </ul>
EMC interference immunity	Acc. to EN 61000-6-2 (industrial environment)
EMC harmonics	Acc. to EN 61000-3-2/3
EMC interference emission	Acc. to EN 61000-6-4 (industrial environment)
Touch current acc. IEC 60990 (measuring network Fig. 4, TN system)	<= 3.5 mA
Motor protection	Thermal overload protector (TOP) wired internally
Cable exit	Variable
Protection class	I (if protective earth is connected by customer)
Product conforming to standard	EN 61800-5-1; CE
Approval	GOST

# EC axial fan - HyBlade®

sickled blades (S series)

with full square nozzle

## Product drawing

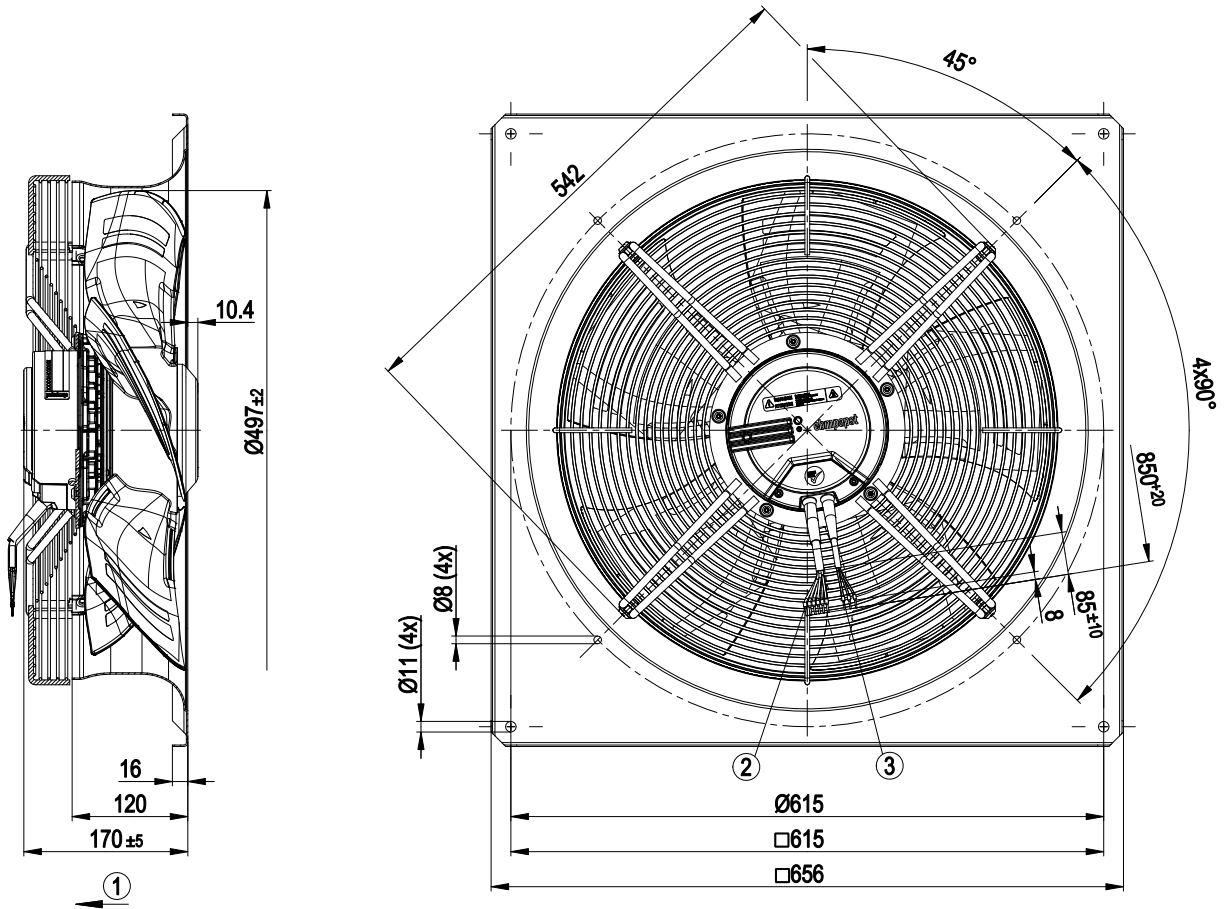

1	Direction of air flow "V"
2	Connection line PVC AWG18, 6 x crimped core-end sleeve
3	Connection line PVC AWG22, 3 x crimped core-end sleeve



# EC axial fan - HyBlade®

sickled blades (S series)

with full square nozzle

## Connection screen

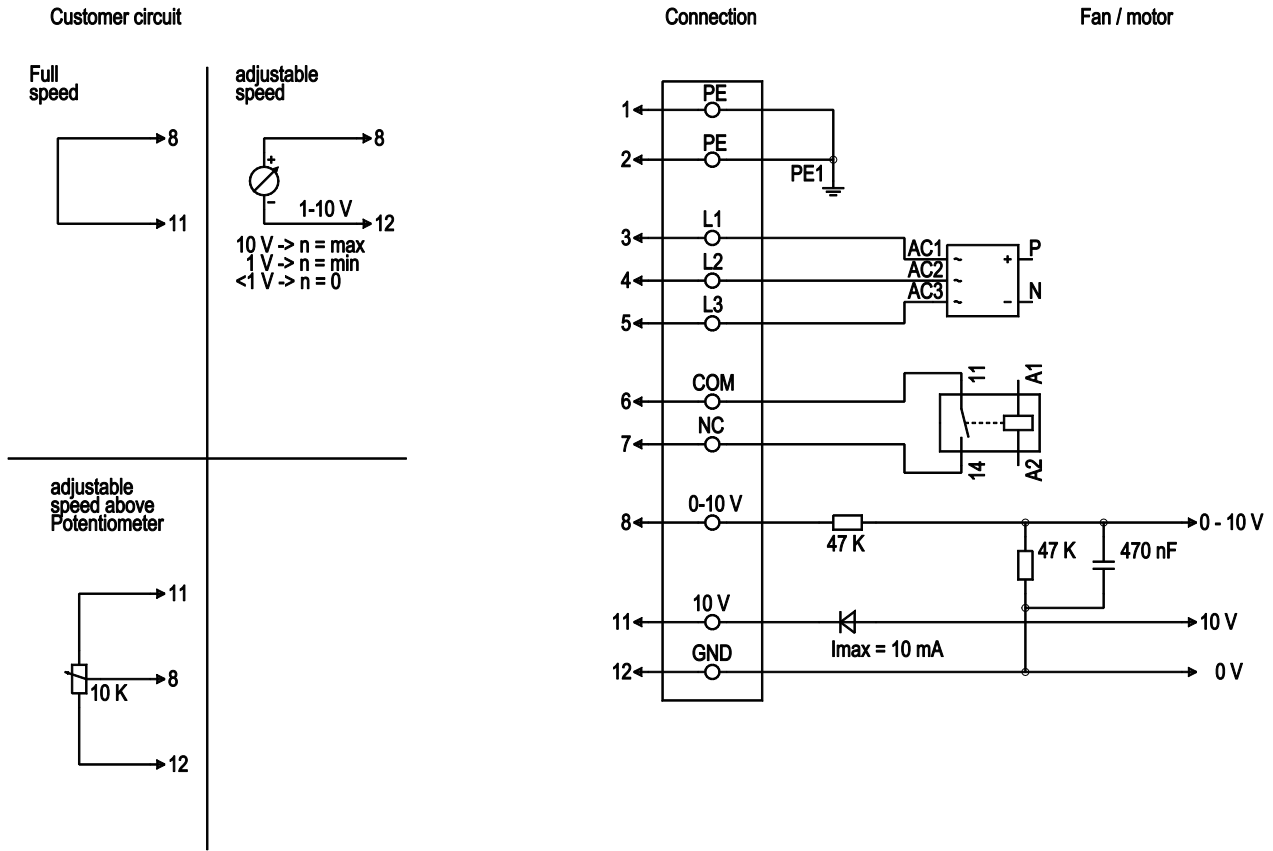

Line	No.	Signal	Colour	Function / assignment
1	1, 2	PE	green/yellow	Protective earth
1	3, 4, 5	L1, L2, L3	black	Supply voltage 50 / 60 Hz
1	6	COM	white 1	Floating status contact, break for failure (2 A, max. 250 VAC, min. 10 mA, AC1)
1	7	NC	white 2	Floating status message contact, break for failure
2	8	0 - 10 V	yellow	Control input, set value 0 - 10 VDC, impedance 100 kOhm, SELV
2	11	+ 10 V	red	Voltage output 10 VDC (+/-3%), max. 10 mA, supply voltage for ext. devices (e.g. potentiometer), SELV
2	12	GND	blue	Reference mass for control interface, SELV



## Charts: Air flow 50 Hz

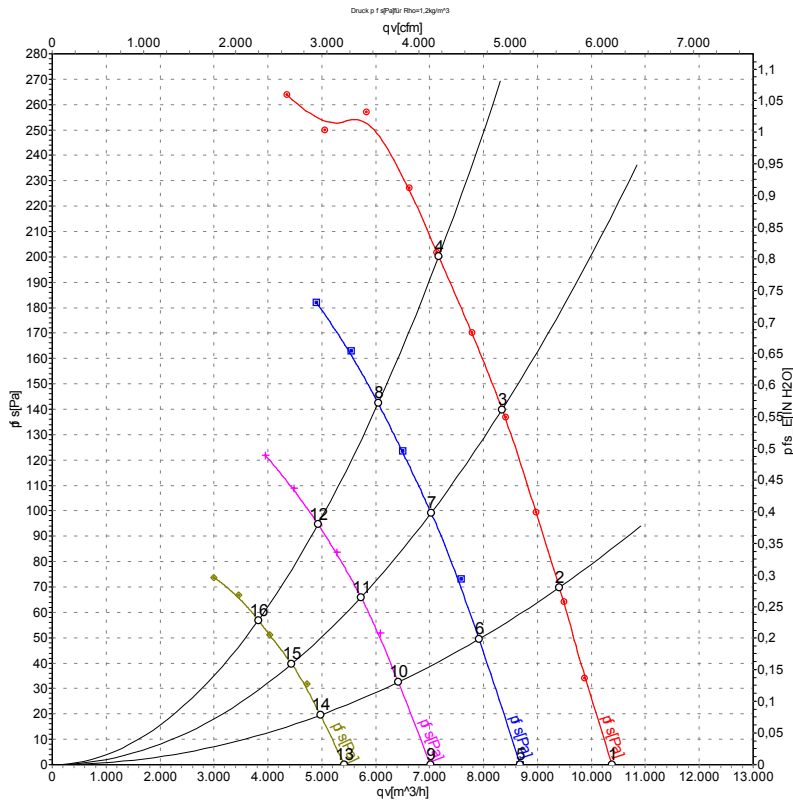

Measurement: LU-121588  
 Measurement: LU-125150  
 Measurement: LU-125151  
 Measurement: LU-125149

Air performance measured as per ISO 5801 Installation category A. For detailed information on the measuring set-up, please contact ebm-papst. Suction-side noise levels: LwA measured as per ISO 13347 / LpA measured with 1m distance to fan axis. The values given are valid under the measuring conditions mentioned above and may vary according to the actual installation situation. With any deviation from the standard set-up, the specific values have to be checked and reviewed with the unit installed.

## Measured values

	U	f	n	P <sub>ed</sub>	I	LpA <sub>in</sub>	LwA <sub>in</sub>	LwA <sub>out</sub>	qv	p <sub>fs</sub>
	V	Hz	min <sup>-1</sup>	W	A	dB(A)	dB(A)	dB(A)	m <sup>3</sup> /h	Pa
1	400	50	1600	734	1.16	72	80	80	10390	0
2	400	50	1600	827	1.33	70	77	77	9405	70
3	400	50	1600	907	1.41	68	75	75	8345	140
4	400	50	1600	980	1.60	68	76	75	7170	200
5	400	50	1350	434	0.78	69	76	76	8680	0
6	400	50	1350	489	0.85	66	73	73	7915	51
7	400	50	1350	538	0.91	64	71	71	7025	99
8	400	50	1350	577	0.95	64	71	71	6045	142
9	400	50	1100	256	0.51	64	72	71	7015	0
10	400	50	1100	282	0.55	62	69	68	6420	33
11	400	50	1100	308	0.60	59	67	66	5730	66
12	400	50	1100	329	0.64	59	66	65	4930	95
13	400	50	850	133	0.31	60	67	66	5415	0
14	400	50	850	145	0.32	57	64	63	4975	20
15	400	50	850	155	0.34	55	62	61	4445	40
16	400	50	850	163	0.36	53	60	60	3820	57

U = Supply voltage · f = Frequency · n = Speed · P<sub>ed</sub> = Power input · I = Current draw · LpA<sub>in</sub> = Sound pressure level inlet side · LwA<sub>in</sub> = Sound power level inlet side · LwA<sub>out</sub> = Sound power level outlet side  
 qv = Air flow · p<sub>fs</sub> = Pressure increase

